

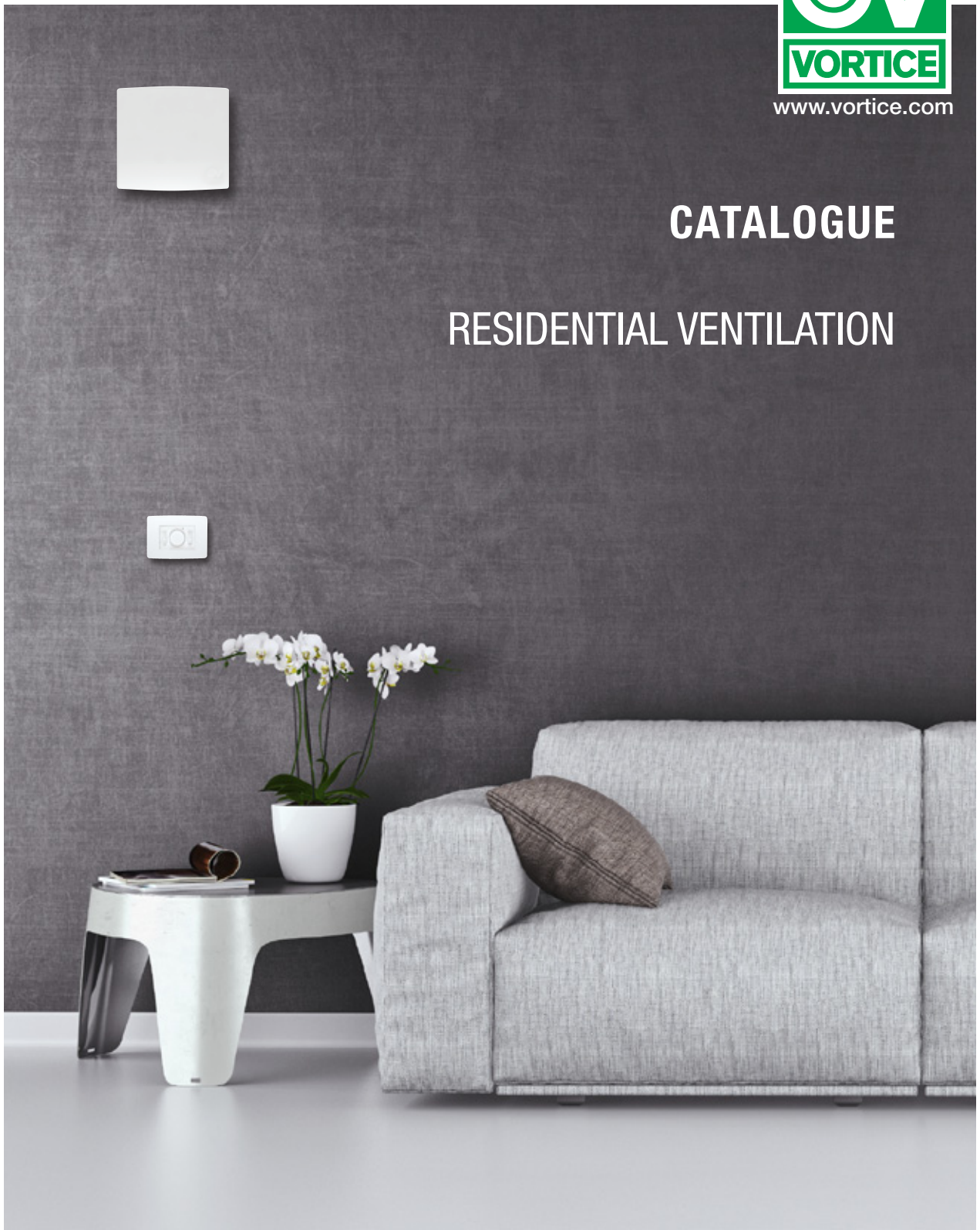

www.vortice.com

CATALOGUE

RESIDENTIAL VENTILATION



NEW

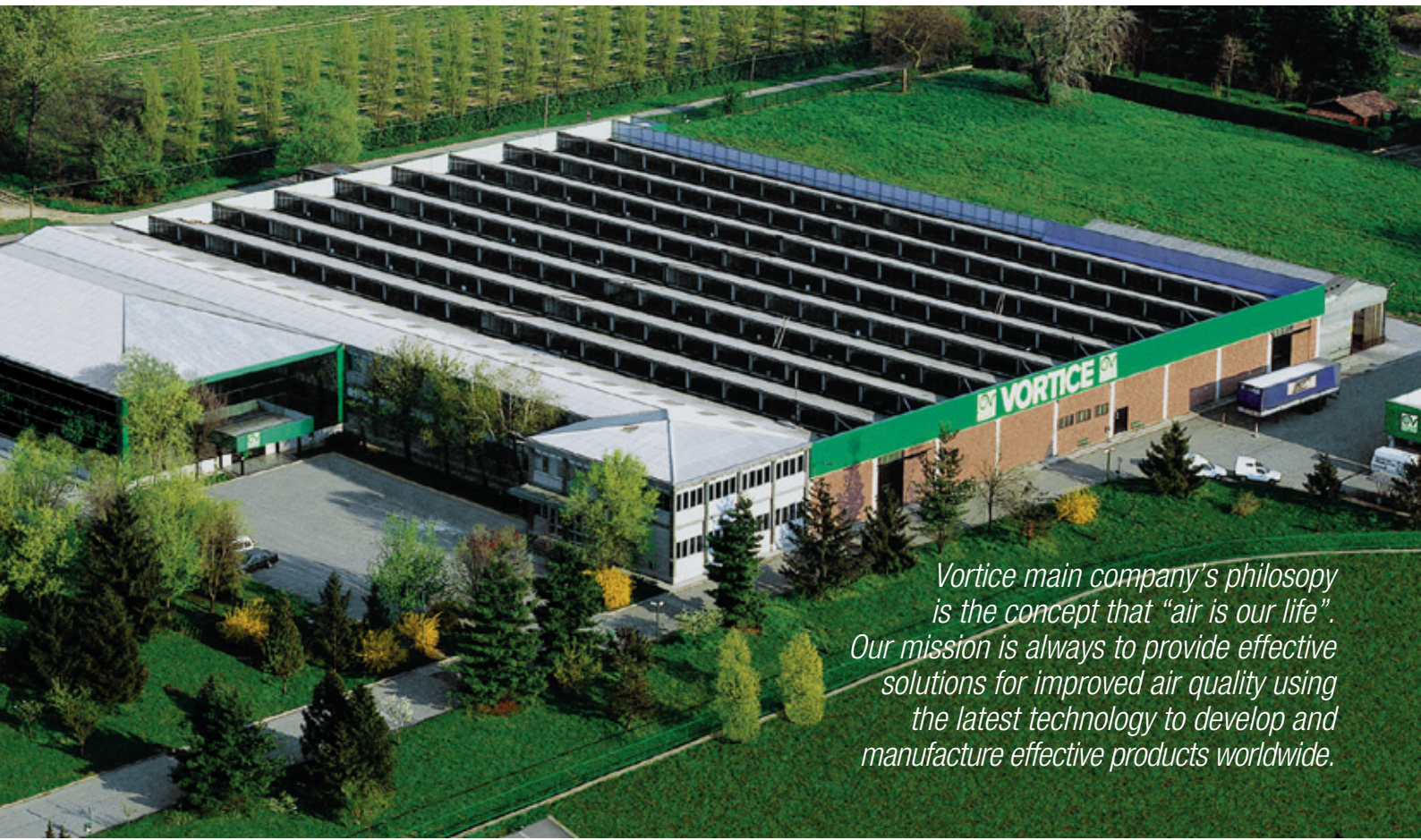

Vortice main company's philosophy is the concept that "air is our life". Our mission is always to provide effective solutions for improved air quality using the latest technology to develop and manufacture effective products worldwide.

Our current Vortice Headquarters have been located in Tribiano (Milan) since 1972.

Vortice has achieved European market leadership by dedicating their efforts to the production of products for ventilation, climate control, heating, extraction, purification and the treatment of air, for domestic, commercial and industrial applications. Since 1954 Vortice has been synonymous with quality and excellence and continues to make significant improvements by investing in continuous research to improve the efficiency and quality of its products.

VORTICE IN THE WORLD

FRANCE



Founded in 1974, Vortice France is located at Créteil about 10 Km from Paris.

ENGLAND



Founded in 1977, Vortice Limited is located at Burton on Trent in the East Midlands.

CHINA



Founded in 2012, Vortice Ventilation System is located about 200 Km from Shanghai.

SOUTH AMERICA



Founded in 2012, Vortice Latam is located in San José, Costa Rica.

INDEX

RESIDENTIAL VENTILATION

- | | | |
|-----|---|--|
| 05 | LEGEND | |
| 06 | PUNTO RANGE
Wall/window axial fans | |
| 12 | PUNTO FILO RANGE
Wall axial fans | |
| 16 | PUNTO FOUR RANGE
Wall axial fans | |
| 20 | PUNTO GHOST RANGE
In-line axial fans | |
| 24 | PUNTO EVO FLEXP RANGE
Wall axial fans | |
| 28 | PUNTO EVO RANGE
Wall axial fans | |
| 34 | PUNTO EVO ES RANGE
Wall axial fans energy savings | |
| 38 | PUNTO EVO GOLD RANGE
Wall axial fans | |
| 42 | VORTICE VARIO RANGE
Wall/window axial fans | |
| 46 | VORTICE VARIO I RANGE
Flush mounted axial fans | |
| 52 | K RANGE
In-line centrifugal fans for kitchen cabinet | |
| 56 | VORTEX® RANGE
Cooker hoods | |
| 58 | VORT KAPPA
Centrifugal canopy fan | |
| 60 | VORT MAX S
Centrifugal duct fans | |
| 64 | ARIETT RANGE
Centrifugal duct fans | |
| 68 | ARIETT I RANGE
Centrifugal duct fans for flush mounting | |
| 72 | ARIETT HABITAT RANGE
Centrifugal duct fans | |
| 76 | VORT PRESS RANGE
Centrifugal duct fans | |
| 80 | VORT PRESS I RANGE
Centrifugal duct fans for flush mounting | |
| 84 | VORT PRESS HABITAT RANGE
Centrifugal duct fans | |
| 88 | VORT QUADRO RANGE
Centrifugal duct fans | |
| 92 | VORT QUADRO I RANGE
Centrifugal duct fans for flush mounting | |
| 96 | VORT NOTUS RANGE
De-centralised continuous axial fans | |
| 100 | VORT PLATT RANGE
Centralised continuous ventilation units | |
| 104 | VORT PENTA RANGE
Centralised continuous ventilation units | |
| 108 | VORT LETO MEV RANGE
Centralised continuous ventilation units | |
| 112 | VORT HRW MONO RANGE
Decentralised continuous axial fans | |
| 118 | VORT PRESS EP RANGE NEW
Centrifugal duct fans | |
| 122 | VORT PRESS I EP RANGE NEW
Centrifugal duct fans | |
| 126 | VORT KAPPA EP NEW
Centrifugal canopy fan | |
| 130 | VORT QUADRO EP AC RANGE NEW
Centrifugal duct fans | |
| 134 | VORT QUADRO I EP AC RANGE NEW
Centrifugal duct fans for flush mounting | |
| 138 | VORT PLATT EP RANGE NEW
Centralised continuous ventilation units | |
| 142 | VORT PENTA EP RANGE NEW
Centralised continuous ventilation units | |
| 146 | RESIDENTIAL VENTILATION ACCESSORIES | |



Air is Life

Vortice replaces the air,
heats it, recovers the heat,
moves it, **cools** the air,
dehumidifies it, purifies it, dries it.



vortice.com

follow us on:



LEGEND



SILENT RUNNING AND CERTIFIED, GUARANTEED PERFORMANCE

IMQ PERFORMANCE is an independent quality mark which certifies, according to international standards, performances (air flow and pressure) and noise levels of the product.



SAFE

Safety, power rating, enclosure protection rating (IP44 to EN 60529) and electrical insulation are certified by IMQ (Quality Mark Institute), the Italian national certifying agency. The IMQ mark certifies that the product is manufactured in compliance with the provisions of relevant established safety standards and directives: (EN 60335-1, EN 60335-2-80 and EN 62333) Low Voltage Directive (LVD) and Electromagnetic Compatibility Directive (EMC). IMQ also guarantees regular, constant monitoring of production quality.



ENERGY SAVING

ES label means that the appliance is fitted with EC Brushless motor and provides high energy savings, thanks to a wide range of speed regulation options and very low consumption levels.



ERP COMPLIANT

The ErP compliant logo indicates that the appliance is eco-compatible and adheres to the ErP directive 2009/125/CE.



LONG LIFE 30.000 H

The Long Life 30,000 h label certifies that the appliance is guaranteed to continuously run at max operating temperature for 30.000 hours without mechanical failure thanks to its motor, equipped with ball bearings.



STANDARD

All models are manufactured with shielded poles and have bronze bearings for a long life



AUTOMATIC

The integral shutters positioned behind the front grille automatically open and close slowly when the unit is operated. The shutters are made from shockproof, anti-UV-treated, plastic.



TIMER

The timer comes on when the light is switched on. When the light is turned off, the unit continues to operate for 3 to 20 minutes, depending on the timer setting.



PIR

The unit turns on a few seconds after the person has entered the room (sensor is located in an inclined position to increase sensitivity), and continues to operate during the person's presence. When the person leaves the room, the unit will continue to run from between 3 to 20 minutes depending on the timer setting.



T-HCS

The appliance features a relative humidity sensor that is factory set at 60%. When relative humidity exceeds that level, the appliance automatically starts up. This threshold setting can however be modified by the installer to 4 levels: 60%, 70%, 80%, and 90%. The unit turns off when the RH drops back to 60% and when the light is switched off, the unit continues to run between 3 to 20 minutes depending on the timer setting.



12 V

A power supply unit is needed wherever the use of low-voltage equipment is required. The two available low-voltage fans - one with and one without automatic shutter - can be used in combination with any of the power supply units.



PULLCORD

The unit is switched on by pulling the insulated pull cord.

CE MARKING

Residential Ventilation products comply with the following European Directives:

2006/95/EC Low Voltage Directive (LVD)
2004/108/EC Electromagnetic Compatibility Directive (EMC)

According to the following state-of-the-art Standards:

Safety

EN 60335-1, EN 60335-2-80, EN 60335-2-40, EN 622233

Electromagnetic Compatibility

EN 55014-1; EN 55014-2; EN 61000-3-2; EN 61000-3-3



Design: F. Trabucco & Associates



PUNTO RANGE

Wall/window axial fans **LONG LIFE 30.000 h**

PRODUCT SPECIFICATIONS

For intermittent or continuous ventilation of bathrooms, toilets, kitchens or utility rooms in domestic or commercial properties.

- **53 models:** from Ø 100 to 150 available with or without the option of automatic shutters, timer, pull cord, humidistat, electronic microprocessor and Passive infrared.
- Motor with shielded poles, either with bronze or ball bearings, and with thermal cut-out.
- Motor support and grille made of anti-UV ABS.
- High airflow rate, low operating noise level and low power consumption due to the wing profile blades and motor support.
- The standard models can be speed regulated.
- Protection rating: IPX4.
- Insulation class: II □.

Punto 12V.

- **8 models:** available with or without automatic shutters; In the automatic version the shutters positioned behind the front grille automatically open and close slowly when the unit is operated.
- The shutters are made from shockproof, anti-UV-treated plastic.
- 12V motor with shielded poles, bronze bearings and thermal cut-out.
- Insulation: Selv Cl.III.



Punto PIR

- **12 models:** The unit turns on a few seconds after the person has entered the room (sensor is located in an inclined position to increase sensitivity), and continues to operate during the person's presence. When the person leaves the room, the unit will continue to run from between 3 to 20 minutes depending on the timer setting.

Punto T-HCS.

- **3 models:** adjustable RH threshold at 60%, 70%, 80%, 90% by mean of a slide switch during installation.
- Smart working mode: the product automatically switches on when the indoor relative humidity level exceeds the pre-set value. A timer automatically switches off the product when the relative humidity decreases under the pre-set limit.

RANGE

		TIMER		PIR <small>Passive Infrared</small>		T-HCS <small>Humidity Control System - Timer</small>	
Ø100		11201 M 100/4" 11641 M 100/4" P	11211 M 100/4" T	11681 M 100/4" PIR			
	LONG LIFE 30.000 h	11202 M 100/4" LL	11212 M 100/4" T LL	11682 M 100/4" PIR LL			
	12 V	11203 M 100/4" 12V 22150 GA 12V	11203 M 100/4" 12V 22151 GA 12V T				
 Ø100		11221 M 100/4" A 11646 M 100/4" AP	11231 M 100/4" AT	11683 M 100/4" A PIR			
	LONG LIFE 30.000 h	11222 M 100/4" A LL	11232 M 100/4" AT LL	11684 M 100/4" A PIR LL		11616 M 100/4" AT HCS LL	
	12 V	11223 M 100/4" 12V 22150 GA 12V	11223 M 100/4" 12V 22151 GA 12V T				
Ø120		11301 M 120/5" 11741 M 120/5" P	11311 M 120/5" T	11781 M 120/5" PIR			
	LONG LIFE 30.000 h	11302 M 120/5" LL	11312 M 120/5" T LL	11782 M 120/5" PIR LL			
	 Ø120	11321 M 120/5" A 11746 M 120/5" AP	11331 M 120/5" AT	11783 M 120/5" A PIR			
	LONG LIFE 30.000 h	11322 M 120/5" A LL	11332 M 120/5" AT LL	11784 M 120/5" A PIR LL		11692 M 120/5" AT HCS LL	
Ø150		11401 M 150/6" 11851 M 150/6" P	11411 M 150/6" T	11881 M 150/6" PIR			
	LONG LIFE 30.000 h	11402 M 150/6" LL	11412 M 150/6" T LL	11882 M 150/6" PIR LL			
	 Ø150	11421 M 150/6" A 11856 M 150/6" AP	11431 M 150/6" AT	11883 M 150/6" A PIR			
	LONG LIFE 30.000 h	11422 M 150/6" A LL	11432 M 150/6" AT LL	11884 M 150/6" A PIR LL		11698 M 150/6" AT HCS LL	

TECHNICAL DATA

Models	V~50Hz	W	A	RPM	Max Airflow		Max Pressure		Lp dB(A) 3 m	Max °C	Kg
					m³/h	l/s	mmH₂O	Pa			
M 90/3.5"	230 - 240	18	0.10	2500	70	19	2.3	23	39.0	50	0.55
M 100/4"				2300	90	25	3	29	37.5		0.60
M 120/5"		20	0.12	2100	175	48.6	4.5	44	39.5		0.80
M 150/6"		30	0.15		335	93.1	6	59	46.0		1.10



RESIDENTIAL VENTILATION

PUNTO RANGE | TECHNICAL DATA FOR REGULATION N° 1254/2014/UE

Models	Unit of measurement	100/4"	100/4" 12V
Supplier's name or trade mark	-	Vortice	Vortice
Specific Energy Consumption class SEC in average climate zone	-	NA	NA
Specific Energy Consumption class SEC average	kWh/m ² a	-6,6	-6,6
Specific Energy Consumption class SEC cold		-20,0	-20,0
Specific Energy Consumption class SEC warm		1,0	1,0
Declared typology	-	RVU-U*	RVU-U*
Type of drive	-	NA	NA
Type of heat recovery system HRS	-	None	None
Thermal efficiency of heat recovery at reference air flow	%	NA	NA
Maximum flow rate	m ³ /s	89	89
Electric power input of the fan drive, including any motor control equipment, at maximum flow rate	W	13,7	13,7
Sound power level LWA	LWA [dB(A)]	58	58
Reference flow rate	m ³ /s	0,0173	0,0174
Reference pressure difference	Pa	15	23
SPI	W/(m ³ /h)	0,21348	0,21253
Control factor CTRL	%	1	1
Control typology	-	manual	manual
Maximum internal leakage rates	-	NA	NA
Maximum external leakage rates	%	NA	NA
Mixing rate	-	NA	NA
Position and description of visual filter warning	-	NA	NA
Airflow sensitivity to pressure variations at + 20 Pa and - 20 Pa	m ³ /h	NA	NA
Indoor/outdoor air tightness	-	NA	NA
Annual electricity consumption (AEC)	kWh electricity/a	294	293
AHS average Annual heating saved	kWh primary energy/a	1397	1397
AHS cold Annual heating saved		2732	2732
AHS warm Annual heating saved		632	632

* RVU-U: Unit Ventilation Residential - Unidirectional

** NRUVU-U: Unit Ventilation Non Residential - Unidirectional

*** MSD: Multi-Speed Drive

PUNTO RANGE | TECHNICAL DATA FOR REGULATION N° 1254/2014/UE

Models	Unit of measurement	120/5"	150/6"
Supplier's name or trade mark	-	Vortice	Vortice
Specific Energy Consumption class SEC in average climate zone	-	NA	NA
Specific Energy Consumption class SEC average	kWh/m ² a	-8,0	-9,7
Specific Energy Consumption class SEC cold		-21,3	-23,0
Specific Energy Consumption class SEC warm		0,3	2,0
Declared typology	-	RVU-U*	RVU-U*
Type of drive	-	NA	NA
Type of heat recovery system HRS	-	None	None
Thermal efficiency of heat recovery at reference air flow	%	NA	NA
Maximum flow rate	m ³ /s	164	324
Electric power input of the fan drive, including any motor control equipment, at maximum flow rate	W	20,6	27,8
Sound power level LWA	LWA [dB(A)]	60	67
Reference flow rate	m ³ /s	0,0319	0,0630
Reference pressure difference	Pa	20	28
SPI	W/(m ³ /h)	0,17422	0,12434
Control factor CTRL	%	1	1
Control typology	-	manual	manual
Maximum internal leakage rates	-	NA	NA
Maximum external leakage rates	%	NA	NA
Mixing rate	-	NA	NA
Position and description of visual filter warning	-	NA	NA
Airflow sensitivity to pressure variations at + 20 Pa and - 20 Pa	m ³ /h	NA	NA
Indoor/outdoor air tightness	-	NA	NA
Annual electricity consumption (AEC)	kWh electricity/a	240	171
AHS average Annual heating saved	kWh primary energy/a	1397	1397
AHS cold Annual heating saved		2732	2732
AHS warm Annual heating saved		632	632

* RVU-U: Unit Ventilation Residential - Unidirectional

** NRVU-U: Unit Ventilation Non Residential - Unidirectional

*** MSD: Multi-Speed Drive



RESIDENTIAL VENTILATION

DIMENSIONS

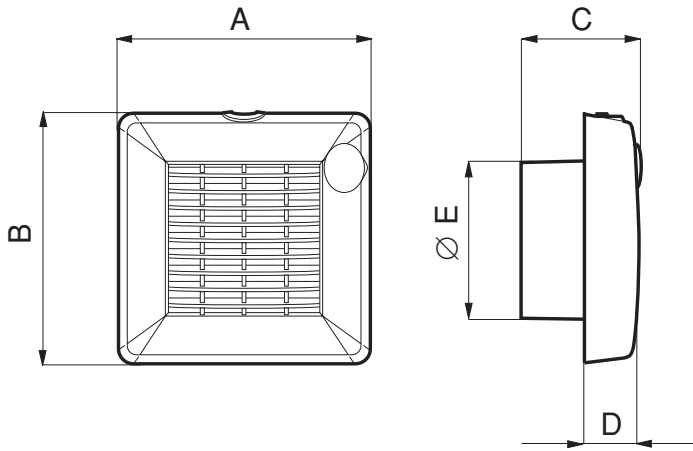

Models	A	B	C	D	Ø E
M 90/3.5"	159	160	100	47	92.5
M 100/4"					99
M 120/5"	179	181	110		119
M 150/6"	214	215	117		156

Dimensions (mm)

PERFORMANCE CURVES

— Power consumption — Delivery

M 90/3,5" cod. 11150 - 11153

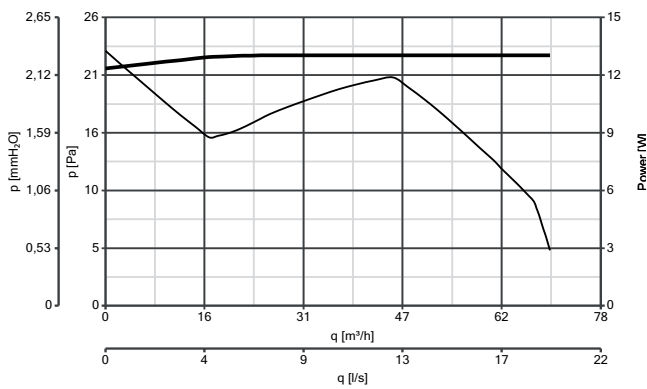

M 100/4" cod. 11201 - 11202 - 11203 - 11211 - 11212 - 11221 - 11222 - 11223 - 11231 - 11232 - 11614 - 11616 - 11646 - 11681 - 11682 - 11683 - 11684

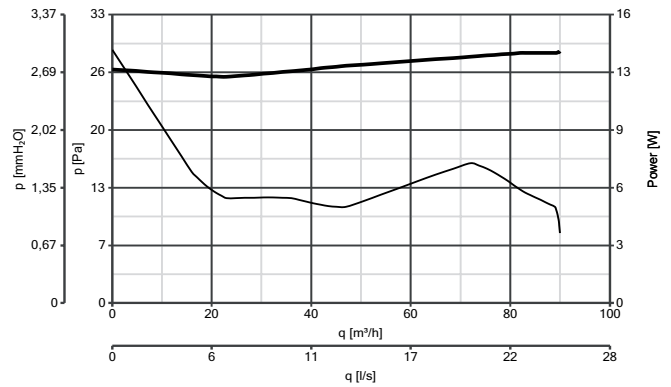

M 120/5" cod. 11301 - 11302 - 11311 - 11312 - 11321 - 11322 - 11331 - 11332 - 11692 - 11741 - 11746 - 11781 - 11782 - 11783 - 11784

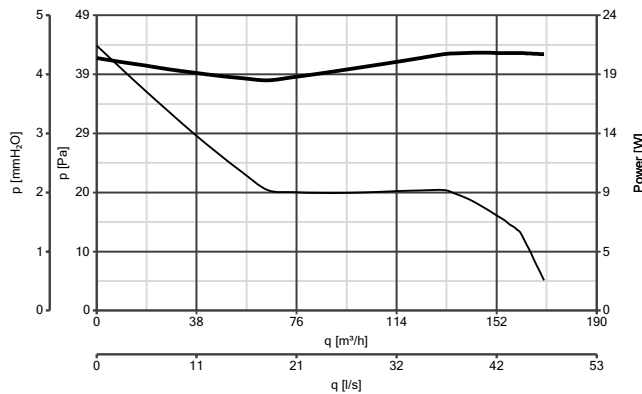

M 150/6" cod. 11401 - 11402 - 11411 - 11412 - 11421 - 11422 - 11431 - 11432 - 11698 - 11851 - 11856 - 11881 - 11882 - 11883 - 11884

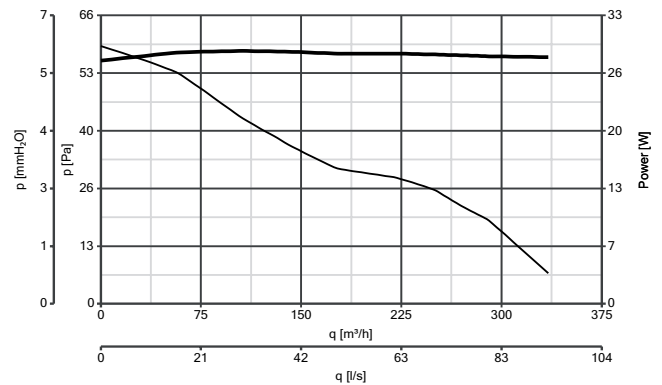

ACCESSORIES ON REQUEST

Models	Description	Code	Product	
	C 1.5 Electronic speed controller 1.5 A	12966	11150 - 11201 - 11202 - 11222- 11301 - 11302 - 11321 - 11322 - 11401- 11402 - 11421 - 11422	
	SCNRB Electronic speed controller built-in	12971	11150 - 11201 - 11202 - 11221 - 11222 - 11301 - 11302 - 11321 - 11322 - 11401 - 11402 - 11421 - 11422	
	SCB KIT Bult-in controller adaptor for C 1.5	22481	12966	
	F KIT Kit to window-mount	100/4"	22131	11201 - 11202 - 11203 - 11211 - 11212 - 11681 - 11682 - 11221 - 11222 - 11223 - 11231 - 11232 - 11683 - 11684 - 11616 - 11614 - 11646
		120/5"	22132	11301 - 11302 - 11311 - 11312 - 11781 - 11782 - 11783 - 11321 - 11322 - 11331 - 11332 - 11741 - 11746- 11784 - 11692
		150/6"	22133	11401 - 11402 - 11411 -11412 - 11881 - 11882 - 11421 - 11422 - 11431 - 11432 - 11851 - 11856 - 11883 - 11884 - 11698
	GFI (Grey Fixed Grille)	100/4"	22010	11150 - 11153 - 11201 - 11202 - 11203 - 11211 - 11212 - 11681 - 11682 - 11221 - 11222 - 11223 - 11231 - 11232 - 11683 - 11684 - 11616
		120/150	22020	11301 - 11302 - 11311 - 11312 - 11781 - 11782 - 11783 - 11321 - 11322 - 11331 - 11332 - 11784 - 11692 - 11401 - 11402 - 11411 - 11412 - 11881 - 11882 - 11421 - 11422 - 11431 - 11432 - 11883 - 11884 - 11698
		GFI 10	22011	
	S Kit Ceiling kit	100/4"	22154	11150 - 11153 - 11201 - 11202 - 11203 - 11211 - 11212 - 11681 - 11682 - 11221 - 11222 - 11223 - 11231 - 11232 - 11683 - 11684 - 11616
		120/5"	22155	11301 - 11302 - 11311 - 11312 - 11781 - 11782 - 11783 - 11321 - 11322 - 11331 - 11332 - 11784 - 11692
		150/6"	22156	11401 - 11402 - 11411 - 11412 - 11881 - 11882 - 11421 - 11422 - 11431 - 11432 - 11883 - 11884 - 11698
	GA	12V	22150	11203 - 11223
		12V T	22151	11203 - 11223

Accessories on request (description and technical data on page 146)

F KIT - KIT TO WINDOW-MOUNT

Technical data and dimensions of the "product+kit".

Models	Kit	Code	W	A	RPM	Max Airflow		Lp dB(A) 3 m	Max °C	Kg
						m³/h	l/s			
M 100/4"	F 100/4"	22131	18	0.10	2300	85	23.6	38	50	0.85
M 120/5"	F 120/5"	22132	20	0.12	2000	140	38.9	40.5		1.15
M 150/6"	F 150/6"	22133	30	0.15	1950	280	77.8	44.5		1.56

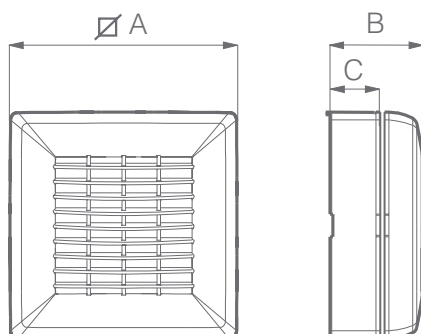

Models	∅ A	B	C	∅ glass hole	Thickness
M 100/4"	158	69	22	123 ÷ 128	20
M 120/5"	179	80	33	143 ÷ 148	
M 150/6"	213	87	40	178 ÷ 183	

Dimensions (mm)



Design: F. Trabucco & Associates

PUNTO FILO RANGE

Wall axial fans **LONG LIFE 30.000 h**

PRODUCT SPECIFICATIONS

For intermittent or continuous ventilation of bathrooms, toilets, kitchens or utility rooms in domestic or commercial properties.

- **21 models:** from 90 to 150 diameters, standard, timer, long life versions.
- Integral backdraught shutter: already installed on the appliance, it prevents unwanted air from getting back in when the appliance is switched off.
- Very silent.
- Quick and easy installation.
- Eco-Friendly: it guarantees a low environmental impact.
- Only 17 mm thickness.
- **Punto Filo T-HCS:** 3 models.
Adjustable Relative Humidity threshold at 60%, 70%, 80%, 90% by means of a slide switch during installation.
- Protection rating: IPX4.
- Insulation class: II



RANGE

TIMER

PIR Passive Infrared

T-HCS Humidity Control System - Timer

Ø	Model	Model	Model	Model
Ø 90	11122 MF 90/3.5"	11126 MF 90/3.5" T		
	LONG LIFE 30.000 h			
Ø100	11123 MF 100/4"	11127 MF 100/4" T		
	LONG LIFE 30.000 h	11131 MF 100/4" LL	11135 MF 100/4" T LL	11185 MF 100/4" PIR LL 11139 MF 100/4" THCS LL
Ø 120	11124 MF 120/5"	11128 MF 120/5" T		
	LONG LIFE 30.000 h	11132 MF 120/5" LL	11136 MF 120/5" T LL	11186 MF 120/5" PIR LL 11149 MF 120/5" THCS LL
Ø 150	11125 MF 150/6"	11129 MF 150/6" T		
	LONG LIFE 30.000 h	11133 MF 150/6" LL	11137 MF 150/6" T LL	11187 MF 150/6" PIR LL 11176 MF 150/6" THCS LL



TECHNICAL DATA

Models	V~50Hz	W	A	RPM	Max Airflow		Max Pressure		Lp dB(A) 3 m	Max °C	Kg
					m³/h	l/s	mmH ₂ O	Pa			
MF 90/3.5"	230 - 240	14	0.08	2500	65	18	2.5	25	28.8	50	0.5
MF 100/4"		15	0.09	2400	85	24	3	29	31.0		
MF 120/5"		20	0.12	2150	175	49	5	49	34.4		
MF 150/6"		28	0.15	2100	335	93	6	59	40.1		

PUNTO FILO RANGE | TECHNICAL DATA FOR REGULATION N° 1254/2014/UE

Models Code	Unit of measurement	MF 90/3.5"	MF 100/4"	MF 120/5"	MF 150/6"
Supplier's name or trade mark	-	Vortice	Vortice	Vortice	Vortice
Specific Energy Consumption class SEC in average climate zone	-	NA	NA	NA	NA
Specific Energy Consumption class SEC average	kWh/m²a	-2,5	-5,4	-8,8	-9,9
Specific Energy Consumption class SEC cold		-15,9	-18,7	-22,1	-23,2
Specific Energy Consumption class SEC warm		5,1	2,3	-1,1	-2,2
Declared typology	-	RVU-U*	RVU-U*	RVU-U*	RVU-U*
Type of drive	-	NA	NA	NA	NA
Type of heat recovery system HRS	-	None	None	None	None
Thermal efficiency of heat recovery at reference air flow	%	NA	NA	NA	NA
Maximum flow rate	m³/s	55	78	173	332
Electric power input of the fan drive, including any motor control equipment, at maximum flow rate	W	12,9	14,1	21,4	26,7
Sound power level LWA	LWA [dB(A)]	49	52	60	61
Reference flow rate	m³/s	0,0107	0,0152	0,0336	0,0646
Reference pressure difference	Pa	19	17	24	32
SPI	W/(m³/h)	0,33247	0,24908	0,15111	0,11833
Control factor CTRL	%	1	1	1	1
Control typology	-	manual	manual	manual	manual
Maximum internal leakage rates	-	NA	NA	NA	NA
Maximum external leakage rates	%	NA	NA	NA	NA
Mixing rate	-	NA	NA	NA	NA
Position and description of visual filter warning	-	NA	NA	NA	NA
Airflow sensitivity to pressure variations at + 20 Pa and - 20 Pa	m³/h	NA	NA	NA	NA
Indoor/outdoor air tightness	-	NA	NA	NA	NA
Annual electricity consumption (AEC)	kWh electricity/a	458	343	208	163
AHS average Annual heating saved	kWh primary energy/a	1397	1397	1397	1397
AHS cold Annual heating saved		2732	2732	2732	2732
AHS warm Annual heating saved		632	632	632	632

* RVU-U: Unit Ventilation Residential - Unidirectional

** NRUVU-U: Unit Ventilation Non Residential - Unidirectional

*** MSD: Multi-Speed Drive



RESIDENTIAL VENTILATION

DIMENSIONS

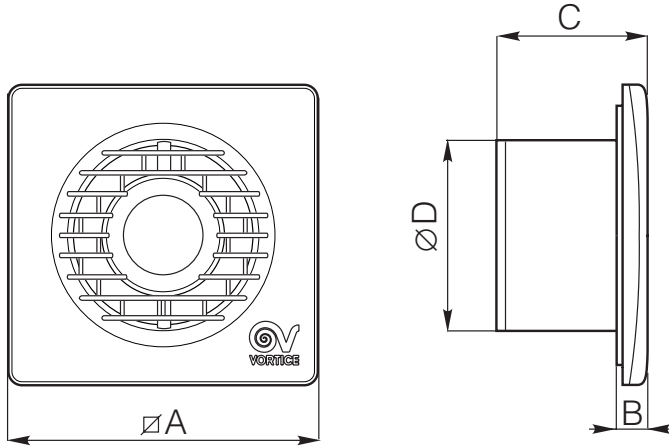

Models	$\varnothing A$	B	C	$\varnothing D$
MF 90/3.5"	159	17	77	92.5
MF 100/4"				98
MF 120/5"	179		89	119
MF 150/6"	214		96	156



Dimensions (mm)

PERFORMANCE CURVES

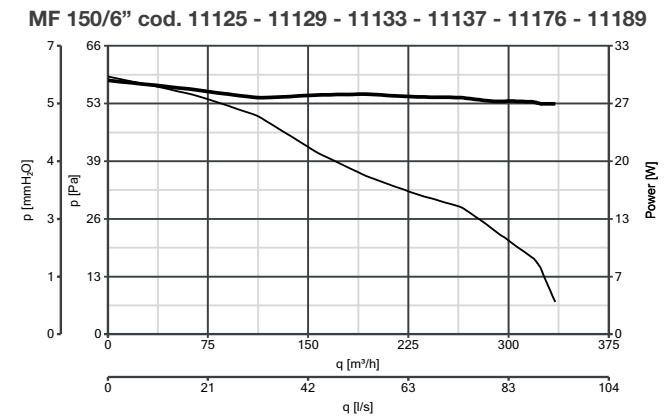
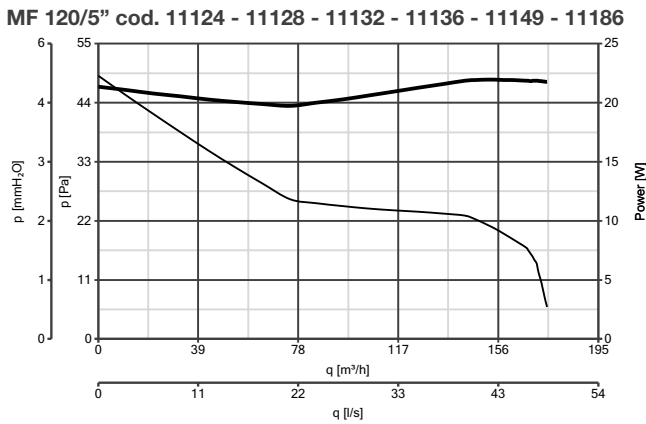
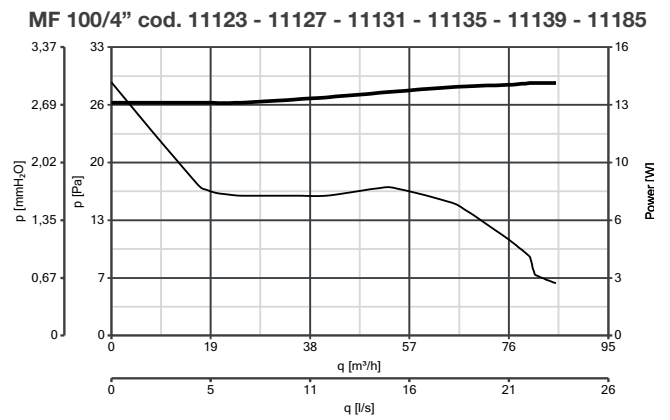
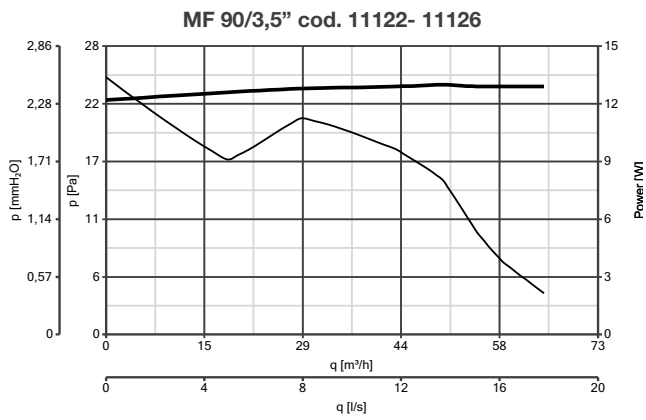
— Power consumption — Delivery



ACCESSORIES ON REQUEST

Models	Description	Code	Product	
	C 1.5 Electronic speed controller 1.5 A	12966	11122 - 11123 - 11131 - 11124 - 11132 - 11125 - 11133	
	SCB KIT Built-in controller adaptor for C 1.5	22481	12966	
	SF KIT - Ceiling kit	90 - 100	22162	11122 - 11126 - 11123 - 11131 - 11127 11135 - 11185 - 11139
		120	22163	11124 - 11132 - 11128 - 11136 - 11186 - 11149
		150	22164	11125 - 11133 - 11129 - 11137 - 11187 - 11176

Accessories on request (description and technical data on page 146)

APPLICATIONS

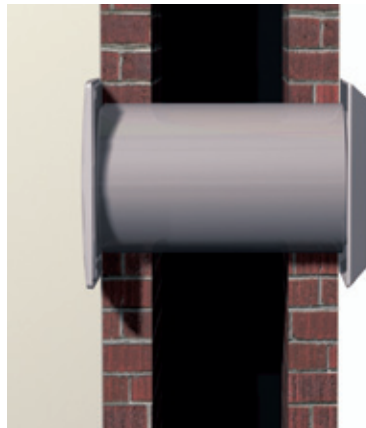



Design: F. Trabucco & Associates

PUNTO FOUR RANGE

Wall axial fans

PRODUCT SPECIFICATIONS

For intermittent or continuous ventilation of bathrooms, toilets, kitchens or utility rooms in domestic or commercial properties.

- **6 models:** from 90 to 120 diameters, with or without timer.
- Body made of ABS plastic anti-UV.
- Integral backdraught shutter.
- Timer models adjustable between 3 and 20 minutes.
- Standard models can be speed regulated.
- Easy to clean and to maintain.
- Ceiling installation and wall installation.
- Protection rating: IPX4.
- Insulation class: II .



TECHNICAL DATA

Models	Code		V~50Hz	W	A	RPM	Max Airflow		Max Pressure		Lp dB(A) 3 m	Max °C	Kg
	basic	timer					m³/h	l/s	mmH ₂ O	Pa			
MFO 90/3.5"	11143	11144	230 - 240	14	0.08	2540	65	18	2.5	25	29.6	50	0.6
MFO 100/4"	11145	11146		15	0.09	2400	85	24	3	29	33.1		
MFO 120/5"	11147	11148		20	0.12	2240	175	49	5	49	39.1		

PUNTO FOUR RANGE | TECHNICAL DATA FOR REGULATION N° 1254/2014/UE

Models Code	Unit of measurement	MFO 90/3,5" MFO 90/3,5" T 11143 - 11144	MFO 100/4" MFO 100/4" T 11145 - 11146	MFO 120/5" MFO 120/5" T 11147 - 11148
Supplier's name or trade mark	-	Vortice	Vortice	Vortice
Specific Energy Consumption class SEC in average climate zone	-	NA	NA	NA
Specific Energy Consumption class SEC average	kWh/m²a	-2,1	-4,1	-8,9
Specific Energy Consumption class SEC cold		-15,5	-17,5	-22,3
Specific Energy Consumption class SEC warm		5,6	3,5	-1,3
Declared typology	-	RVU-U*	RVU-U*	RVU-U*
Type of drive	-	NA	NA	NA
Type of heat recovery system HRS	-	None	None	None
Thermal efficiency of heat recovery at reference air flow	%	NA	NA	NA
Maximum flow rate	m³/s	54	68	171
Electric power input of the fan drive, including any motor control equipment, at maximum flow rate	W	12,9	14,0	18,5
Sound power level LWA	LWA [dB(A)]	50	54	60
Reference flow rate	m³/s	0,0104	0,0132	0,0333
Reference pressure difference	Pa	19	14	19
SPI	W/(m³/h)	0,34446	0,28571	0,14620
Control factor CTRL	%	1	1	1
Control typology	-	manual	manual	manual
Maximum internal leakage rates	-	NA	NA	NA
Maximum external leakage rates	%	NA	NA	NA
Mixing rate	-	NA	NA	NA
Position and description of visual filter warning	-	NA	NA	NA
Airflow sensitivity to pressure variations at + 20 Pa and - 20 Pa	m³/h	NA	NA	NA
Indoor/outdoor air tightness	-	NA	NA	NA
Annual electricity consumption (AEC)	kWh electricity/a	475	394	201
AHS average Annual heating saved	kWh primary energy/a	1397	1397	1397
AHS cold Annual heating saved		2732	2732	2732
AHS warm Annual heating saved		632	632	632

* RVU-U: Unit Ventilation Residential - Unidirectional
 ** NRVU-U: Unit Ventilation Non Residential - Unidirectional
 *** MSD: Multi-Speed Drive

DIMENSIONS

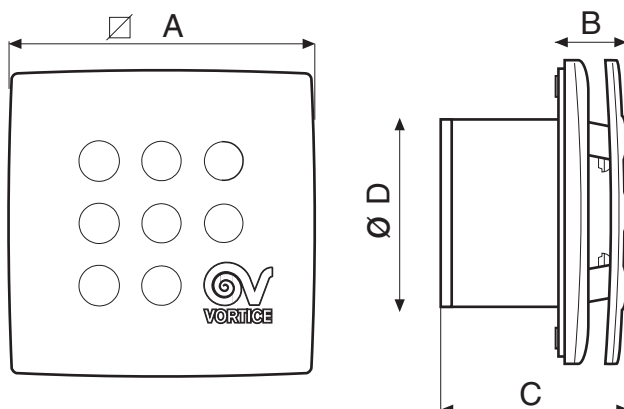

Models	Ø A	B	C	Ø D
MFO 90/3.5"	158	37	97	92.4
MFO 100/4"				98.4
MFO 120/5"	178	42.3	114	118.9

Dimensions (mm)

PERFORMANCE CURVES

— Power consumption — Delivery

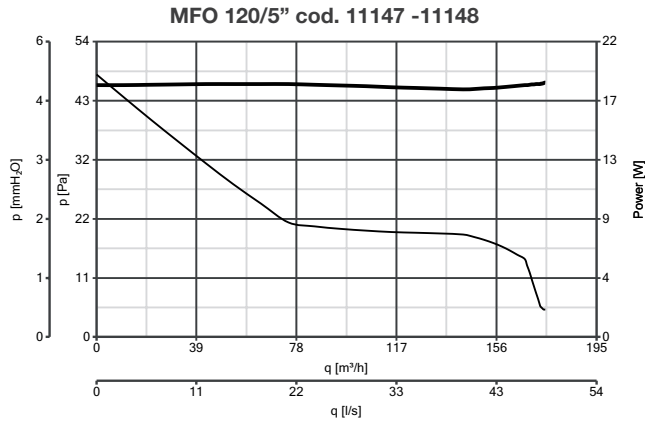
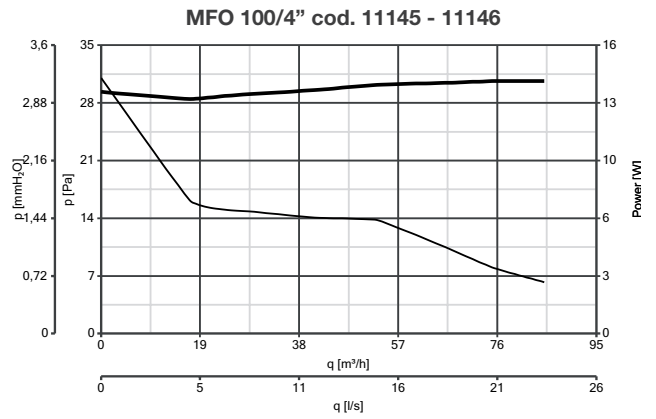
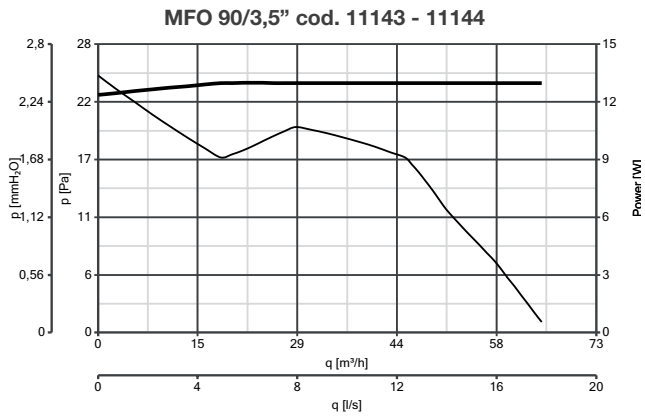

ACCESSORIES ON REQUEST

Models	Description	Code	Product
	C 1.5 Electronic speed controller 1.5 A	12966	11143 - 11145 - 11147
	SCB KIT Built-in controller adaptor for C 1.5	22481	12966
	SF KIT - Ceiling kit	90 - 100	22162 11143 - 11144 - 11145 - 11146
		120	22163 11147 - 11148

Accessories on request (description and technical data on page 146)

APPLICATIONS

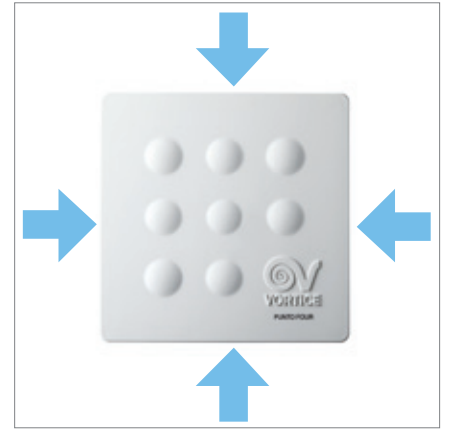
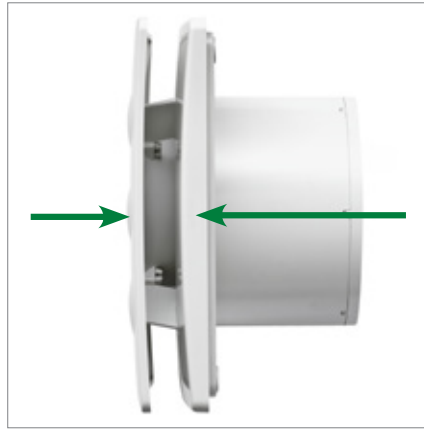



PUNTO GHOST RANGE

In-line axial fans **LONG LIFE 30.000 h**



Design: F. Trabucco & Associates

PRODUCT SPECIFICATIONS

Suitable for installation in walls, ceilings/false ceilings, lofts, internal walls.

- **10 models:** from Ø 90 to 150 available with or without timer.
- Can be used as temperature blenders in adjacent rooms.
- Motor with shielded poles and ball bearings (30.000 h guaranteed continuous operation) with thermal cut-out. Except codes (11110- 11111 -11116-11117).
- Complies with the requirements of Part F1 of the Building Regulations even when connected on 3 m flexible aluminium duct (with 2 x 90° bends).
- Protection rating: IPX4.
- Insulation class: II □.



TECHNICAL DATA

Models	Code		V~50Hz	W	A	RPM	Max Airflow		Max Pressure		Lp dB(A) 3 m	Max °C	Kg	
	basic	timer					m³/h	l/s	mmH₂O	Pa				
MG 90/3.5"	11110	11111	230 - 240	18	0,10	2450	65	18	2.1	21	38	40	0,40	
MG 100/4" LL	11100	11101				2415	80	22,2	2.6	25	39		0,43	
MGK 100/4" LL	11106	-					22,2				0,90			
MG 120/5"	11116	-		230 - 240	20	0,12	2250	160	44	4.5	44	50	0,56	
MG 120/5" LL	11102	11103							44,4					
MG 150/6"	11117	-			30	0,18	2200	320	89	7.0	69		48	0,80
MG 150/6" LL	11104	11105							88,9					

PUNTO GHOST RANGE | TECHNICAL DATA FOR REGULATION N° 1254/2014/UE

Models Code	Unit of measurement	MG 90/3.5" - MG 100/4" LL	MG 120/5" MG 120/5" LL	MG 150/6" MG 150/6" LL
		11110 - 11100 - 11101 - 11106	11116 - 11102 - 11103	11117 - 11104 - 11105
Supplier's name or trade mark	-	Vortice	Vortice	Vortice
Specific Energy Consumption class SEC in average climate zone	-	NA	NA	NA
Specific Energy Consumption class SEC average	kWh/m²a	-5,4	-7,6	-10,0
Specific Energy Consumption class SEC cold		-18,8	-21,0	-23,4
Specific Energy Consumption class SEC warm		2,2	0,0	-2,4
Declared typology	-	RVU-U*	RVU-U*	RVU-U*
Type of drive	-	NA	NA	NA
Type of heat recovery system HRS	-	None	None	None
Thermal efficiency of heat recovery at reference air flow	%	NA	NA	NA
Maximum flow rate	m³/s	77	157	311
Electric power input of the fan drive, including any motor control equipment, at maximum flow rate	W	13,7	20,5	25,0
Sound power level LWA	LWA [dB(A)]	60	64	69
Reference flow rate	m³/s	0,0150	0,0305	0,0605
Reference pressure difference	Pa	14	18	30
SPI	W/(m³/h)	0,24861	0,18471	0,11484
Control factor CTRL	%	1	1	1
Control typology	-	manual	manual	manual
Maximum internal leakage rates	-	NA	NA	NA
Maximum external leakage rates	%	NA	NA	NA
Mixing rate	-	NA	NA	NA
Position and description of visual filter warning	-	NA	NA	NA
Airflow sensitivity to pressure variations at + 20 Pa and - 20 Pa	m³/h	NA	NA	NA
Indoor/outdoor air tightness	-	NA	NA	NA
Annual electricity consumption (AEC)	kWh electricity/a	343	255	158
AHS average Annual heating saved	kWh primary energy/a	1397	1397	1397
AHS cold Annual heating saved		2732	2732	2732
AHS warm Annual heating saved		632	632	632

* RVU-U: Unit Ventilation Residential - Unidirectional
 ** NRVU-U: Unit Ventilation Non Residential - Unidirectional
 *** MSD: Multi-Speed Drive

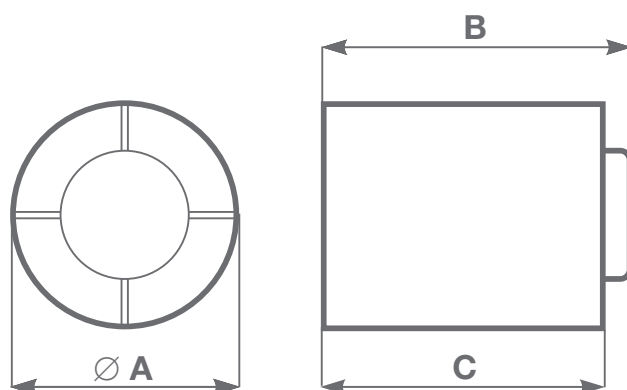
DIMENSIONS

Models	Ø A	B	C
MG 90/3.5"	92.5	92	89
MG 90/3.5" T		96.5	
MG 100/4" LL	99	92	
MG 100/4" LL T		96.5	
MG 120/5"	119	103	100
MG 120/5" LL		107.5	
MG 120/5" T LL		110	
MG 150/6"	155	110	107
MG 150/6" LL		114.5	
MG 150/6" T LL		115	
MGK 100/4" LL	99	115	110

Dimensions (mm)

PERFORMANCE CURVES

— Power consumption — Delivery

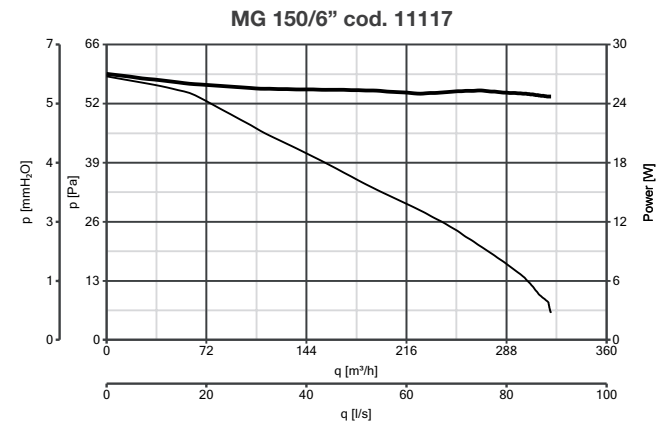
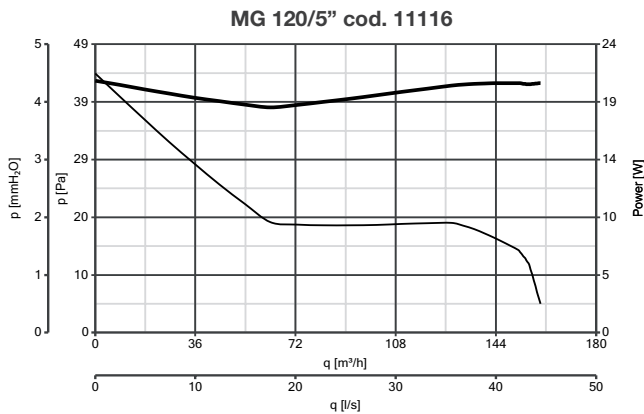
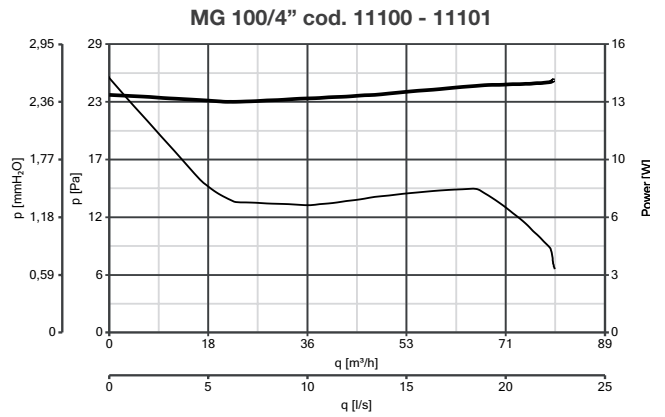
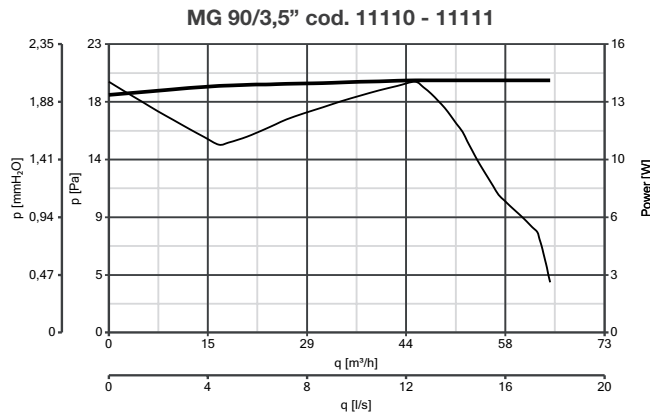

ACCESSORIES ON REQUEST

Models	Description	Code	Product	
	C 1.5 Electronic speed controller 1.5 A	12966	11110 - 11100 - 11116 - 11102 - 11117 - 11104	
	SCNRB Electronic speed controller built-in	12971	11110 - 11116 - 11117	
	SCB KIT Built-in controller adaptor for C 1.5	22481	12966	
	Flexible duct	Ø 90/100	22250	11110 - 11111
		Ø 120	22251	11116 - 11102 - 11103
		Ø 150	22252	11117 - 11104 - 11105
	Telescopic wall liner	Ø 100/4	22256	11110 - 11111
		Ø 120/5	22257	11116 - 11102 - 11103
		Ø 150/6	22258	11117 - 11104 - 11105
	Loft mounting brackets	Ø 90/100	22259	11110 - 11111 - 11100 - 11101
		Ø 120	22260	11116 - 11102 - 11103
		Ø 150	22261	11117 - 11104 - 11105
	Grille kit	90/3	22143	11110 - 11111
		100/4	22140	11100 - 11101
		120/5	22141	11116
		150/6	22142	11117

Accessories on request (description and technical data on page 146)

APPLICATION

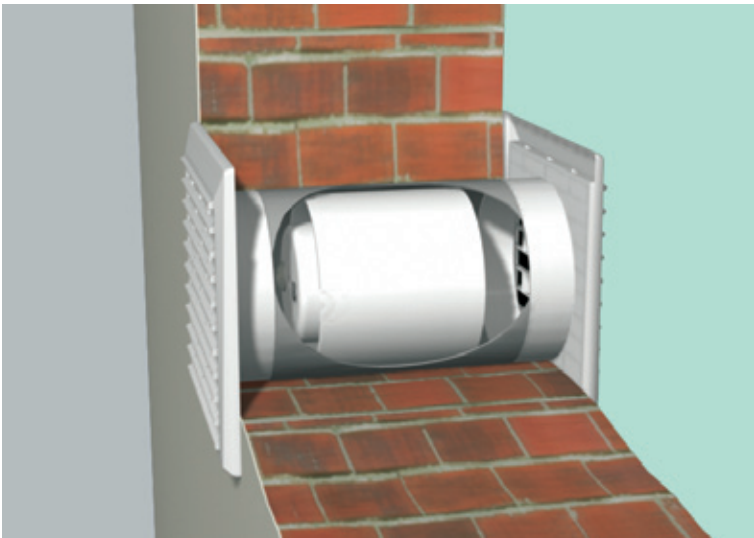



SERIE PUNTO EVO FLEXXO

Wall axial fans **LONG LIFE** 30.000 h

PRODUCT SPECIFICATIONS

Suitable for wall and ceiling installation; designed for stile air extraction through walls or short ducts.

- **2 versions: Standard, Timer (T).**
- 2 nominal diameters: 100 mm and 120 mm.
- For intermittent or continuous ventilation.
- Front panel, motor holder and integrated backdraught shutter made of ABS thermoplastic shockproof and anti-UV resin.
- Helico-centrifugal mixed-flow impellers made of PP resin.
- Impellers and motor holder specifically designed for high performance, low power consumption and low noise emissions.
- Integrated butterfly backdraught shutter designed to prevent unwanted air inflows when the appliance is switched off.
- Designed to provide a low environmental impact, using recyclable materials and following the new "Design for Disassembly" technique to achieve easy and environmentally friendly disposal of components.
- Typical wall/panel, false wall, ceiling and false ceiling installations.
- The reduced mounting depth makes it ideal to fit even when the installation space is limited due to the proximity of elbow bends (90°).
- Unique anch stylish design.
- Compact size.
- Reduced depth: 61,5 mm for models Ø 100 e 71 mm for models Ø 120.
- Protection rating: IPX5 and IP45.
- Insulation class: II □.



IPX5

TECHNICAL DATA

models	Code	V~50Hz	W max	A max	RPM max	Max Airflow		Max Pressure		Lp dB(A) 3m	Max °C	Kg	
						m³/h	l/s	mmH ₂ O	Pa				
MEX 100/4" LL 1S	11313	230	9	0.052	2175	90	25	4	39.23	26.9	50	0.60	
MEX 100/4" LL 1S T	11314												
MEX 120/5" LL 1S	11333		13	0.095	2075	175	48.6	5	49.04	32.3			0.77
MEX 120/5" LL 1S T	11334												

PUNTO EVO FLEXO RANGE | TECHNICAL DATA FOR REGULATION N° 1254/2014/UE

	Models Code	Unit of measurement	MEX 100/4" LL 11313 - 11314	MEX 120/5" LL 11333 - 11334
Supplier's name or trade mark		-	Vortice	Vortice
Specific Energy Consumption class SEC in average climate zone		-	NA	NA
Specific Energy Consumption class SEC average			-9,9	-10,0
Specific Energy Consumption class SEC cold		kWh/m²a	-23,2	-23,4
Specific Energy Consumption class SEC warm			-2,2	-2,4
Declared typology		-	RVU-U*	RVU-U*
Type of drive		-	NA	NA
Type of heat recovery system HRS		-	None	None
Thermal efficiency of heat recovery at reference air flow		%	NA	NA
Maximum flow rate		m³/s	87	168
Electric power input of the fan drive, including any motor control equipment, at maximum flow rate		W	8,0	14,1
Sound power level LWA		LWA [dB(A)]	47	53
Reference flow rate		m³/s	0,0169	0,0327
Reference pressure difference		Pa	21	19
SPI		W/(m³/h)	0,11823	0,11480
Control factor CTRL		%	1	1
Control typology		-	manual	manual
Maximum internal leakage rates		-	NA	NA
Maximum external leakage rates		%	NA	NA
Mixing rate		-	NA	NA
Airflow sensitivity to pressure variations at + 20 Pa and - 20 Pa		m³/h	NA	NA
Indoor/outdoor air tightness		-	NA	NA
Annual electricity consumption (AEC)		kWh electricity/a	163	158
AHS average Annual heating saved		kWh primary energy/a	1397	1397
AHS cold Annual heating saved			2732	2732
AHS warm Annual heating saved			632	632
Position and description of visual filter warning		-	NA	NA

* RVU-U: Unit Ventilation Residential - Unidirectional
 ** NRVU-U: Unit Ventilation Non Residential - Unidirectional
 *** MSD: Multi-Speed Drive

DIMENSIONS

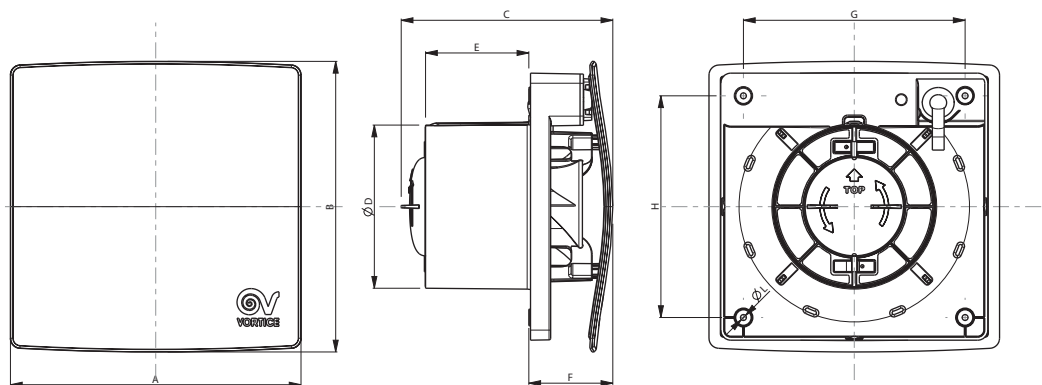

Models	A	B	C	Ø D	E	F	G	H	Ø L
MEX 100/4" LL	173	173	126	98	61.5	50	132	132	3.5
MEX 120/5" LL	193	193	138	119	71	53	152	152	

Dimensions (mm)



RESIDENTIAL VENTILATION

EXPLODED VIEW

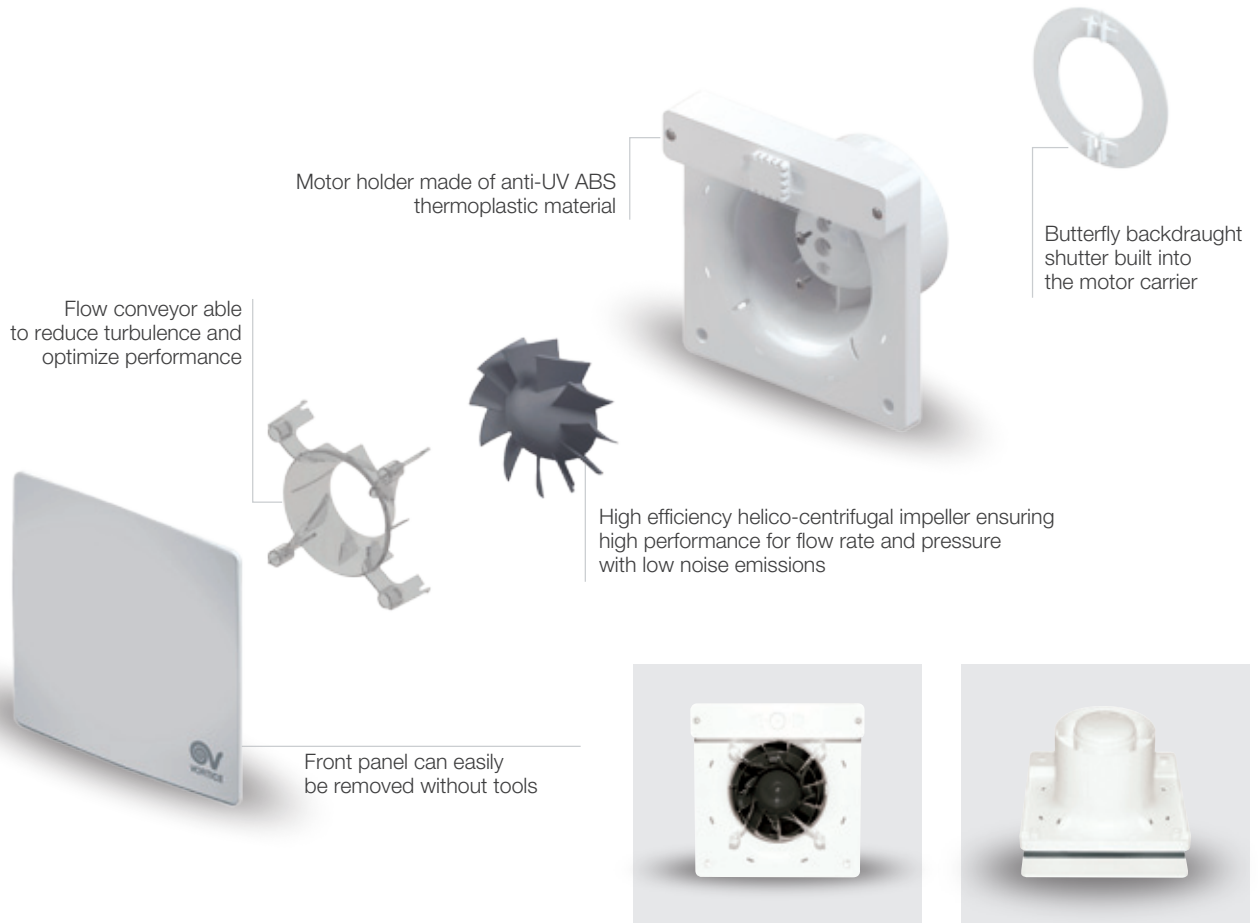

PERFORMANCE CURVES

— Power consumption — Delivery

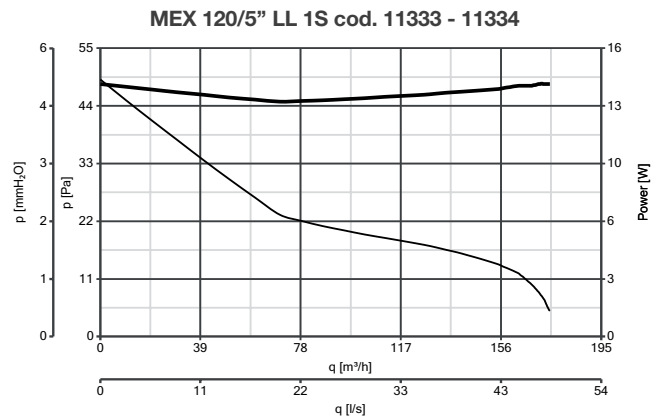
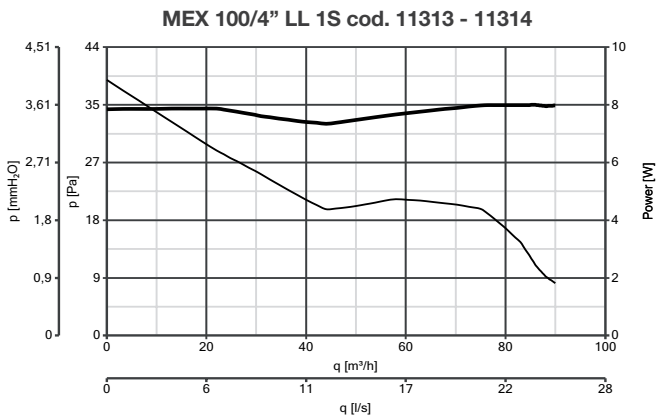



APPLICATIONS

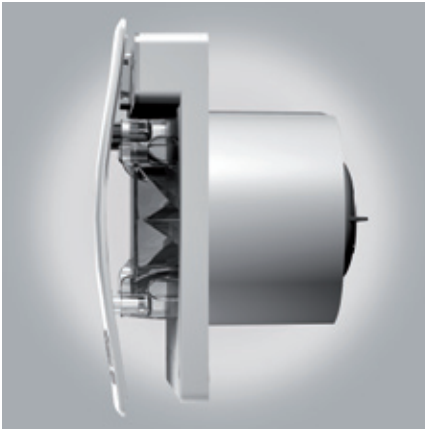



PUNTO EVO RANGE

Wall axial fans **LONG LIFE** 30.000 h

PRODUCT SPECIFICATIONS

Suitable for wall and ceiling installation; designed for stile air extraction through walls or short ducts.

- **5 versions: Standard, Timer (T), Advanced Timer (TP), Humidity control (HCS), Infrared motion sensor (PIR).**
- 2 nominal diameters: 100 mm and 120 mm.
- 2 speeds.
- Shock-proof, UV resistant, ABS made enclosures.
- Helico-centrifugal mixed-flow impellers made of PP resin.
- Motor carriers with airfoil flow straighteners.
- Aerodynamically optimised impellers and internal geometry.
- Impellers and motor holder specifically designed for high performance, low power consumption and low noise emissions.
- Integrated butterfly backdraught shutter designed to prevent unwanted air inflows when the appliance is switched off.
- Long-life ball-bearing motors guaranteed for 30,000 hours continuous trouble-free operation.
- Designed to provide a low environmental impact, using recyclable materials and following the new "Design for Disassembly" technique to achieve easy and environmentally friendly disposal of components.
- Short mounting depth, ideal for installations close to 90° (elbow) pipe bends.
- Protection rating: IPX5 and IP45 suitable for installation in zone 1 of bathroom.
- Insulation class: II .



IPX5

RANGE

Ø 100	LONG LIFE 30.000 h 11260 ME 100/4" LL	11264 ME 100/4" LL T	11261 ME 100/4" LL TP	11262 ME 100/4" LL TP HCS	11263 ME 100/4" LL PIR
Ø 120	LONG LIFE 30.000 h 11270 ME 120/5" LL	11274 ME 120/5" LL T	11271 ME 120/5" LL TP	11272 ME 120/5" LL TP HCS	11273 ME 120/5" LL PIR



The **Basic version** is equipped with a 2-speed PCB.



The **Timer version** is equipped with a PCB for time-lagged appliance switch-off. The appliance is preset for a minimum operating time of 3 minutes; it is possible to adjust the timer from approximately 3 to 20 minutes. The appliance switches on automatically straight after the light is switched on and continues to run for the set time after the light is switched off. During installation you can choose the operating speed of the appliance, min. or max. speed.



The **Timer Plus version** is equipped with a PCB that enables time-lagged switching on and/or off of the appliance at the min. or max. speed. The time lag for switching on and off, as well as the operating speed, are set during installation. In addition, the appliance can run automatic switch-on daily cycles. This function is very useful to avoid the concentration of relative humidity in environments rarely inhabited.



The **Timer PIR version** features a PCB with an infrared presence sensor able to automatically activate the appliance whenever anyone is in its range of action. In addition, thanks to the Timer, the PCB enables time-lagged switch-off, for a preset time adjustable from 3 to 20 minutes. The switch-off time, as well as the operating speed (min. or max. speed), can be set during installation.



The **Timer Plus HCS version** features a PCB with a Timer Evoluto and a humidity sensor able to automatically activate the appliance whenever the ambient relative humidity values exceed the preset limit or when it grows rapidly. The factory preset value is 70%. The relative humidity value can in any case be set by the installer on 4 values: 60%, 70%, 80%, 90%. The PCB moreover permits time-lagged switching on and/or off at the min. or max. speed.

TECHNICAL DATA

Models	V-50Hz	W min/max	A min/max	RPM min/max	Max Airflow		Max Pressure		Lp dB(A) 3m min/max	Lw dB(A) min/max	Max °C	Kg
					m³/h min/max	l/s min/max	mmH₂O min/max	Pa min/max				
ME 100/4" LL	230	5 9	0.039 0.052	1700 2240	65 95	18.1 26.4	2.5 4.7	24.52 46.09	20.8 26.9	41.3 47.4	50	0.60
ME 120/5" LL		10 13	0.060 0.080	1490 2070	120 175	33.3 48.6	2.3 5.0	22.56 49.04	24.0 32.3	44.5 52.8		0.77



RESIDENTIAL VENTILATION

PUNTO EVO RANGE | TECHNICAL DATA FOR REGULATION N° 1254/2014/UE

	Models Code	Unit of measurement	ME 100/4" LL	ME 120/5" LL
Supplier's name or trade mark		-	Vortice	Vortice
Specific Energy Consumption class SEC in average climate zone		-	NA	NA
Specific Energy Consumption class SEC average		kWh/m ² a	-9,9	-9,9
Specific Energy Consumption class SEC cold			-23,2	-23,3
Specific Energy Consumption class SEC warm			-2,2	-2,3
Declared typology		-	RVU-U*	RVU-U*
Type of drive		-	NA	NA
Type of heat recovery system HRS		-	None	None
Thermal efficiency of heat recovery at reference air flow		%	NA	NA
Maximum flow rate		m ³ /s	93	168
Electric power input of the fan drive, including any motor control equipment, at maximum flow rate		W	8,1	14,5
Sound power level LWA		LWA [dB(A)]	68	53
Reference flow rate		m ³ /s	0,0181	0,0327
Reference pressure difference		Pa	22	18
SPI		W/(m ³ /h)	0,11828	0,11735
Control factor CTRL		%	1	1
Control typology		-	manual	manual
Maximum internal leakage rates		-	NA	NA
Maximum external leakage rates		%	NA	NA
Mixing rate		-	NA	NA
Position and description of visual filter warning		-	NA	NA
Airflow sensitivity to pressure variations at + 20 Pa and - 20 Pa		m ³ /h	NA	NA
Indoor/outdoor air tightness		-	NA	NA
Annual electricity consumption (AEC)		kWh electricity/a	163	162
AHS average Annual heating saved		kWh primary energy/a	1397	1397
AHS cold Annual heating saved			2732	2732
AHS warm Annual heating saved			632	632

* RVU-U: Unit Ventilation Residential - Unidirectional

** NRUVU-U: Unit Ventilation Non Residential - Unidirectional

*** MSD: Multi-Speed Drive

DIMENSIONS

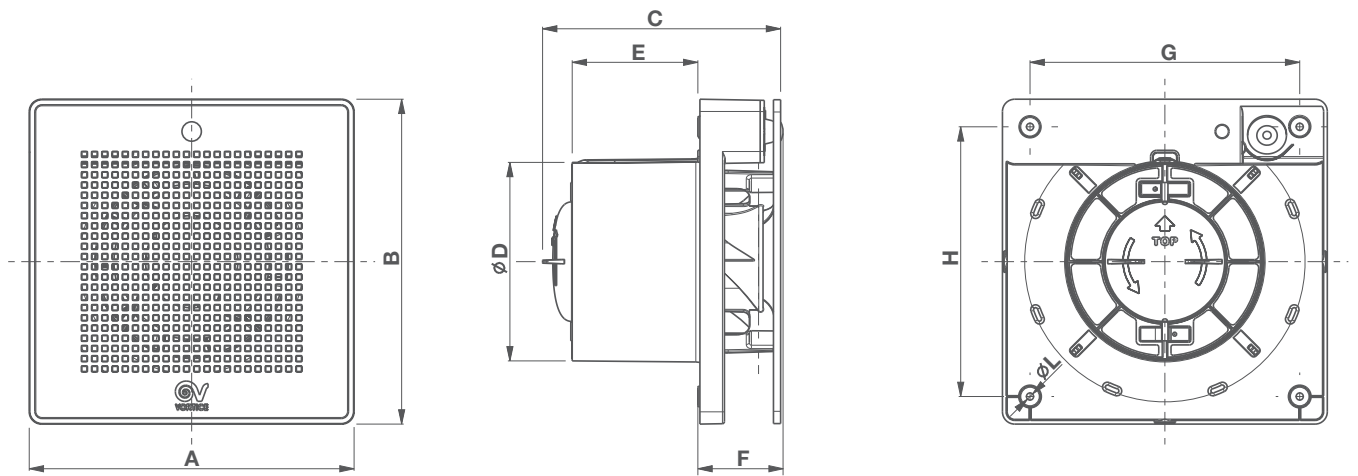

Models	A	B	C	Ø D	E	F	G	H	Ø L
ME 100/4" LL	159	159	116.5	98	61.5	40.5	132	132	3.5
ME 100/4" LL PIR			118			42			
ME 120/5" LL	179	179	127	118	71	42.5	152	152	
ME 120/5" LL PIR			128.5			44			

Dimensions (mm)

EXPLODED VIEW

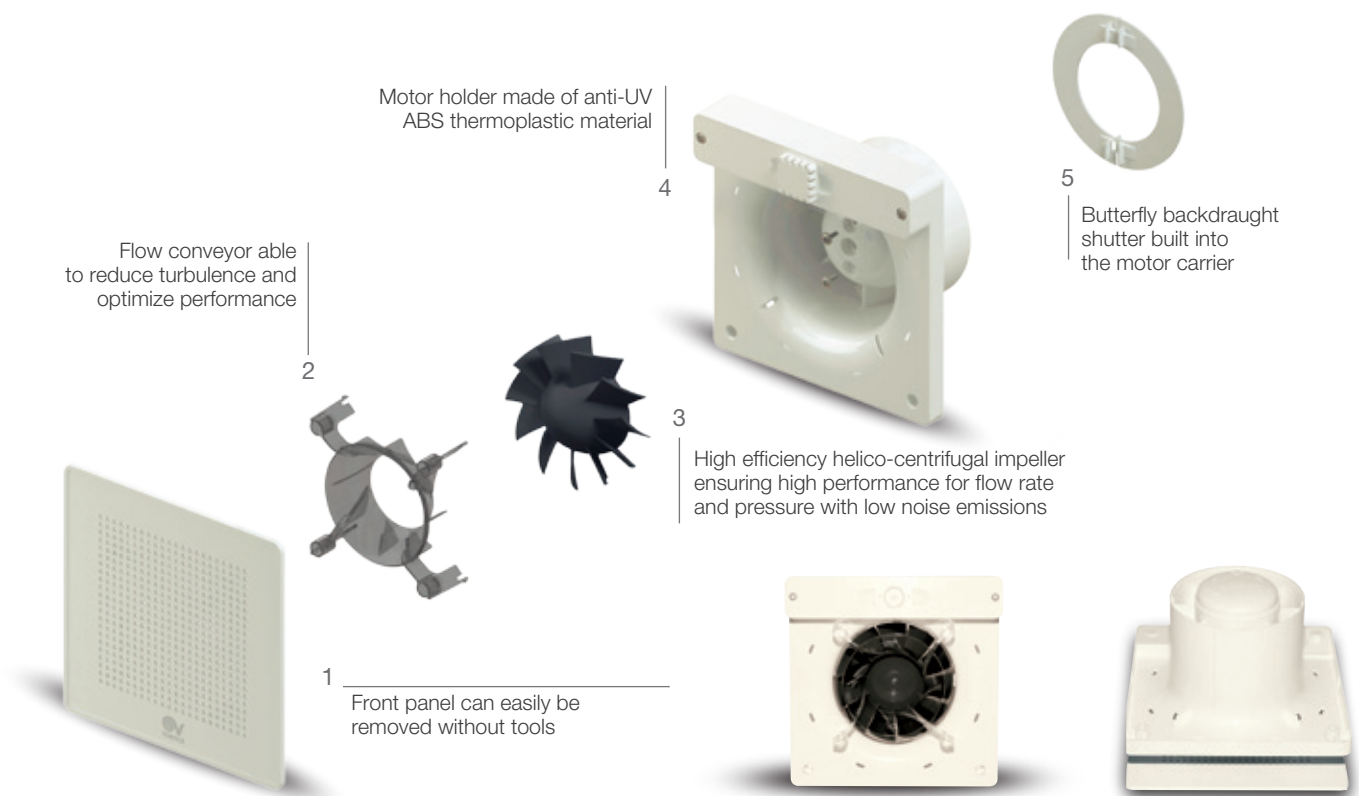



PERFORMANCE CURVES

POWER CONSUMPTION PERFORMACE CURVES
 — max — max
 — min — min

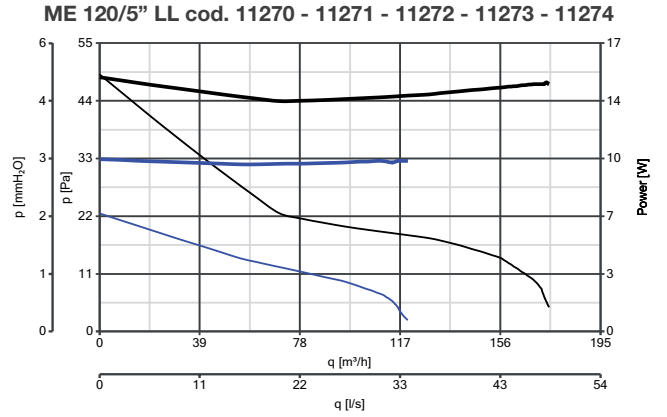
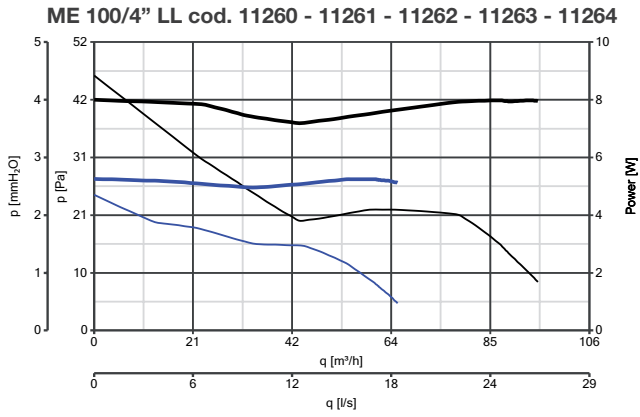

APPLICATIONS

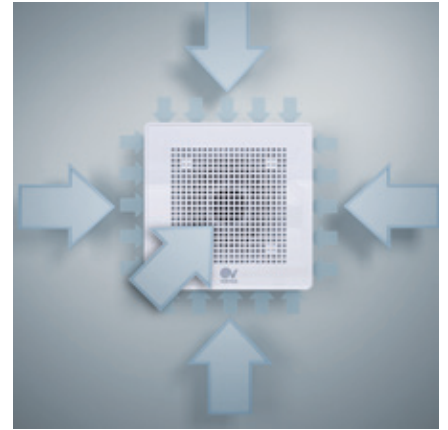



PUNTO EVO ES RANGE

Wall axial fans energy savings **LONG LIFE 30.000 h**

PRODUCT SPECIFICATIONS

Suitable for wall and ceiling installation; designed for stile air extraction through walls or short ducts.

- **2 nominal diameters:** 100 mm, 120 mm.
- Short mounting depth, ideal for installations close to 90° (elbow) pipe bends.
- ES versions equipped with brushless EC motors for even lower power consumption. Two-speed motors, with ball bearings, guaranteed for 30,000 hours of continuous operation.
- Impact-resistant ABS enclosures with anti-UV treatment.
- Aerodynamically optimised impellers and internal geometry.
- Impellers and motor holder specifically designed for high performance, low power consumption and low noise emissions.
- Safety-certified by IMQ in accordance with the applicable international standards.
- ES models allow to activate, during installation, Timer function; in detail, 3 distinct operating modes are available, depending on electrical connection:
 - continuous operating at minimum speed;
 - continuous operating at maximum speed;
 - Two speed operation: the product runs at minimum speed; by selecting maximum speed (eg. turning on the light), it switches to maximum speed and then returns to minimum speed 6 minutes after the light has been switched off.
- Integrated butterfly backdraught shutter designed to prevent unwanted air inflows when the appliance is switched off.
- Protection rating: IPX 5 and IP45 suitable for installation in zone 1 of bathroom.
- Insulation class: II .



IPX5

TECHNICAL DATA

Models	Code	V~50Hz	W min/max	A min/max	RPM min/max	Max Airflow		Max Pressure		Lp dB(A) 3m min/max	Lw dB(A) min/max	Max °C	Kg
						m³/h min/max	l/s min/max	mmH₂O min/max	Pa min/max				
ME 100/4" ES	11268	230	2.1 3.6	0.030 0.041	1680 2280	65 95	18.1 26.4	2.7 5.1	26.5 50.0	21.0 27.8	41.5 48.3	50	0.64
ME 120/5" ES	11269		3.3 7.0	0.040 0.068	1680 2150	130 180	36.1 50.0	3.6 5.8	35.3 56.9	26.2 33.3	46.7 53.8		

PUNTO EVO ES RANGE | TECHNICAL DATA FOR REGULATION N° 1254/2014/UE

	Models Code	Unit of measurement	ME 100/4" ES	ME 120/5" ES
			11268	11269
Supplier's name or trade mark	-	-	Vortice	Vortice
Specific Energy Consumption class SEC in average climate zone	-	-	NA	NA
Specific Energy Consumption class SEC average	-	-	-12,1	-12,3
Specific Energy Consumption class SEC cold	-	kWh/m²a	-25,5	-25,6
Specific Energy Consumption class SEC warm	-	-	-4,5	-4,6
Declared typology	-	-	RVU-U*	RVU-U*
Type of drive	-	-	NA	NA
Type of heat recovery system HRS	-	-	None	None
Thermal efficiency of heat recovery at reference air flow	-	%	NA	NA
Maximum flow rate	-	m³/s	89	175
Electric power input of the fan drive, including any motor control equipment, at maximum flow rate	-	W	3,5	6,6
Sound power level LWA	-	LWA [dB(A)]	48	54
Reference flow rate	-	m³/s	0,0173	0,0340
Reference pressure difference	-	Pa	21	20
SPI	-	W/(m³/h)	0,05297	0,04980
Control factor CTRL	-	%	1	1
Control typology	-	-	manual	manual
Maximum internal leakage rates	-	-	NA	NA
Maximum external leakage rates	-	%	NA	NA
Mixing rate	-	-	NA	NA
Position and description of visual filter warning	-	-	NA	NA
Airflow sensitivity to pressure variations at + 20 Pa and - 20 Pa	-	m³/h	NA	NA
Indoor/outdoor air tightness	-	-	NA	NA
Annual electricity consumption (AEC)	-	kWh electricity/a	73	69
AHS average Annual heating saved	-	kWh primary energy/a	1397	1397
AHS cold Annual heating saved	-		2732	2732
AHS warm Annual heating saved	-		632	632

* RVU-U: Unit Ventilation Residential - Unidirectional
 ** NRUVU-U: Unit Ventilation Non Residential - Unidirectional
 *** MSD: Multi-Speed Drive

DIMENSIONS

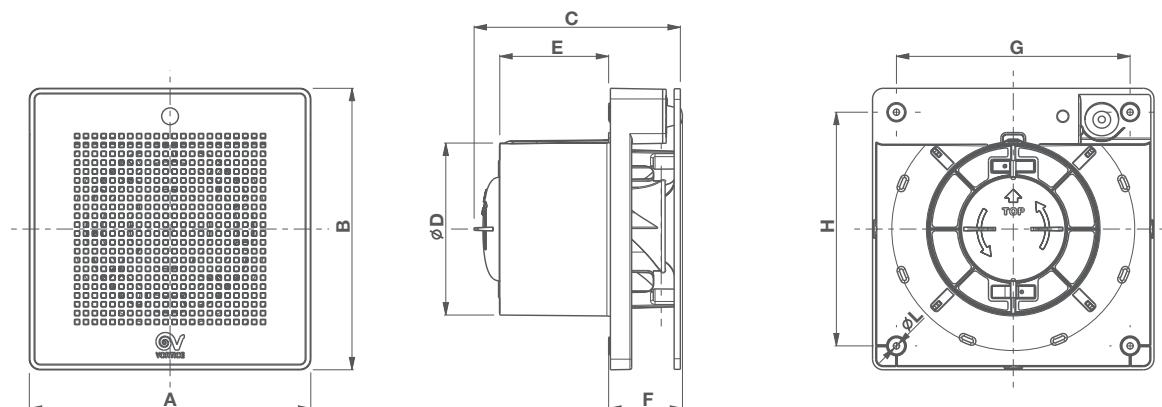

Models	A	B	C	Ø D	E	F	G	H	Ø L
ME 100/4" ES	159	159	132	98	77.5	40.5	132	132	3.5
ME 120/5" ES	179	179	138	118	81	42.5	152	152	

Dimensions (mm)



RESIDENTIAL VENTILATION

EXPLODED VIEW

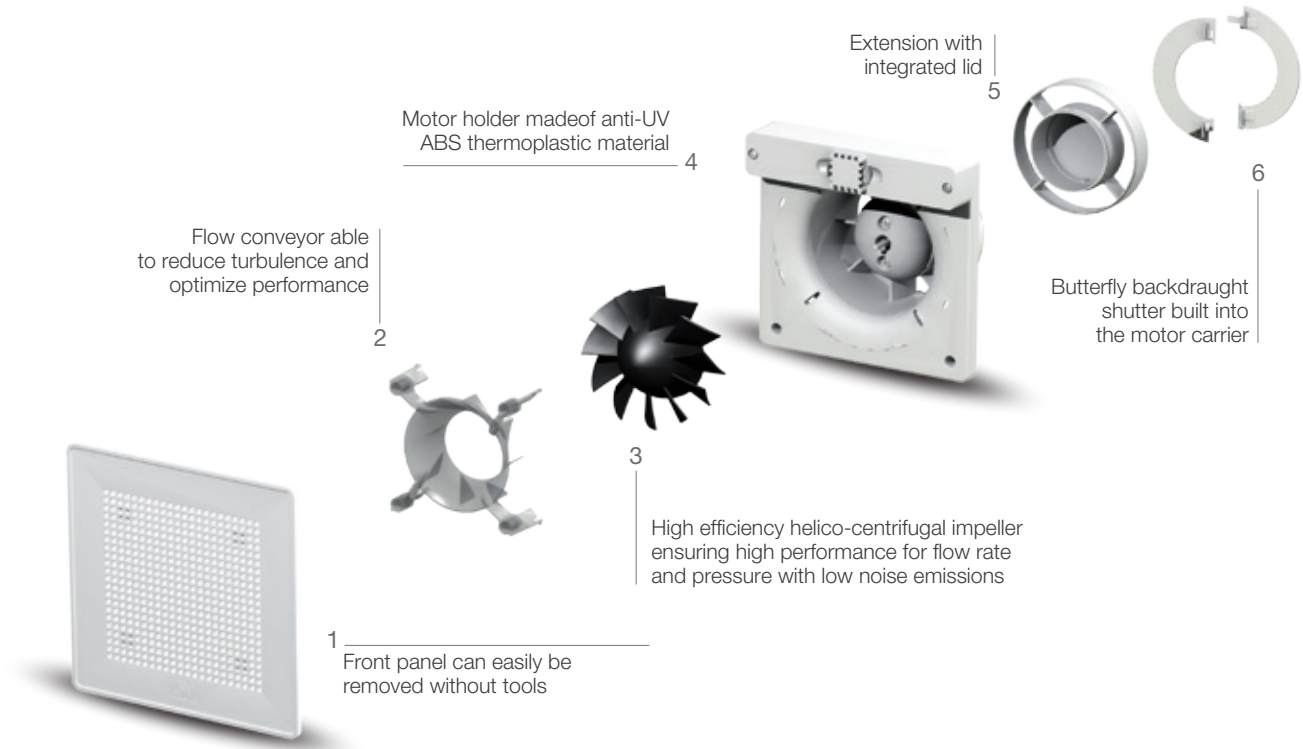

PERFORMANCE CURVES

POWER CONSUMPTION
 — max
 — min

PERFORMANCE CURVES
 — max
 — min

ME 100/4" cod. 11268

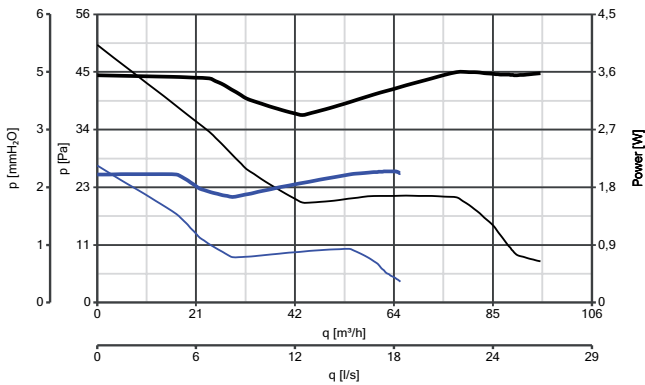

ME 120/5" ES cod. 11269

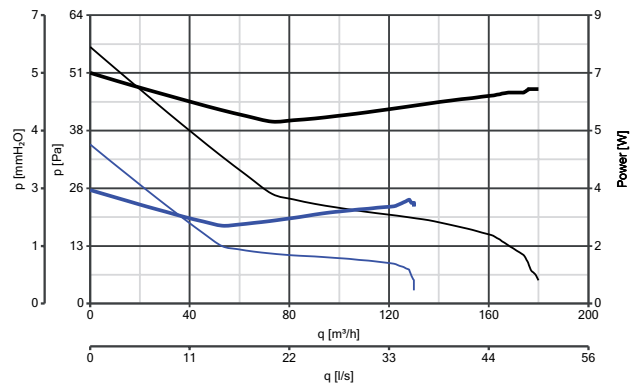

APPLICATIONS

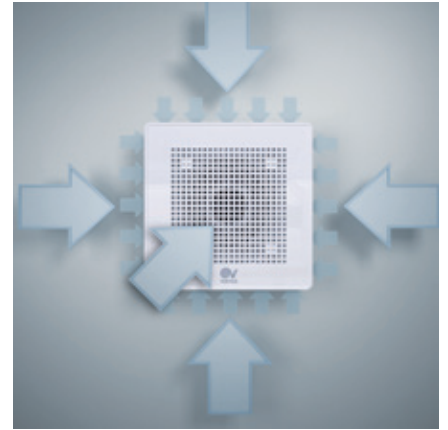



PUNTO EVO GOLD RANGE

Wall axial fans **LONG LIFE** 30.000 h

PRODUCT SPECIFICATIONS

Suitable for wall and ceiling installation; designed for stipe air extraction through walls or short ducts.

- **2 versions: Standard, Timer (T).**
- 1 nominal diameters: 100 mm.
- 2 speeds.
- The GOLD versions of PUNTO EVO feature a stylish metallic mirror finish in four colour nuances (Pink, Yellow, Black and White Gold) obtained through advanced technologies, providing an attractive and distinctive style, durability and wear resistance.
- Short mounting depth, ideal for installations close to 90° (elbow) pipe bends.
- Long-life ball-bearing motors guaranteed for 30,000 hours continuous trouble-free operation.
- Shock-proof, UV resistant, ABS made enclosures.
- Helico-centrifugal mixed-flow impellers made of PP resin.
- Motor carriers with airfoil flow straighteners.
- Impellers and motor holder specifically designed for high performance, low power consumption and low noise emissions.
- Designed to provide a low environmental impact, using recyclable materials and following the new “Design for Disassembly” technique to achieve easy and environmentally friendly disposal of components..
- Integrated butterfly backdraught shutter designed to prevent unwanted air inflows when the appliance is switched off.
- Protection rating: IP45.
- Insulation class: II □.



IPX5

RANGE

			PUNTO EVO Gold YELLOW GOLD	PUNTO EVO Gold PINK GOLD	PUNTO EVO Gold BLACK GOLD	PUNTO EVO Gold WHITE GOLD
Ø 100	LONG LIFE 30.000 h		11306 ME 100/4" LL	11307 ME 100/4" LL	11308 ME 100/4" LL	11309 ME 100/4" LL
	LONG LIFE 30.000 h		11316 ME 100/4" LL T	11317 ME 100/4" LL T	11318 ME 100/4" LL T	11319 ME 100/4" LL T



The **Basic version** is equipped with a 2-speed PCB.



The **Timer version** is equipped with a PCB for time-lagged appliance switch-off. The appliance is preset for a minimum operating time of 3 minutes; it is possible to adjust the timer from approximately 3 to 20 minutes. The appliance switches on automatically straight after the light is switched on and continues to run for the set time after the light is switched off. During installation you can choose the operating speed of the appliance, min. or max. speed.



TECHNICAL DATA

Models	V~50Hz	W min/max	A min/max	RPM min/max	Max Airflow		Max Pressure		Lp dB(A) 3m min/max	Lw dB(A) min/max	Max °C	Kg
					m³/h min/max	l/s min/max	mmH ₂ O min/max	Pa min/max				
ME 100/4" LL	230	5 9	0.039 0.052	1700 2240	65 95	18.1 26.4	2.5 4.7	24.52 46.09	20.8 26.9	41.3 47.4	50	0.60

PUNTO EVO GOLD RANGE | TECHNICAL DATA FOR REGULATION N° 1254/2014/UE

	Models Code	Unit of measurement	ME 100/4" LL
			11306 - 11307 - 11308 - 11309 - 11316 - 11317 - 11318 - 11319
Supplier's name or trade mark	-	-	Vortice
Specific Energy Consumption class SEC in average climate zone	-	-	NA
Specific Energy Consumption class SEC average	kWh/m²a		-9,9
Specific Energy Consumption class SEC cold			-23,2
Specific Energy Consumption class SEC warm			-2,2
Declared typology	-	-	RVU-U*
Type of drive	-	-	NA
Type of heat recovery system HRS	-	-	None
Thermal efficiency of heat recovery at reference air flow	%		NA
Maximum flow rate	m³/s		93
Electric power input of the fan drive, including any motor control equipment, at maximum flow rate	W		8,1
Sound power level LWA	LWA [dB(A)]		68
Reference flow rate	m³/s		0,0181
Reference pressure difference	Pa		22
SPI	W/(m³/h)		0,11828
Control factor CTRL	%		1
Control typology	-		manual
Maximum internal leakage rates	-		NA
Maximum external leakage rates	%		NA
Mixing rate	-		NA
Airflow sensitivity to pressure variations at + 20 Pa and - 20 Pa	m³/h		NA
Indoor/outdoor air tightness	-		NA
Annual electricity consumption (AEC)	kWh electricity/a		163
AHS average Annual heating saved	kWh primary energy/a		1397
AHS cold Annual heating saved		2732	
AHS warm Annual heating saved		632	
Position and description of visual filter warning	-		NA

* RVU-U: Unit Ventilation Residential - Unidirectional
 ** NRUV-U: Unit Ventilation Non Residential - Unidirectional
 *** MSD: Multi-Speed Drive



DIMENSIONS

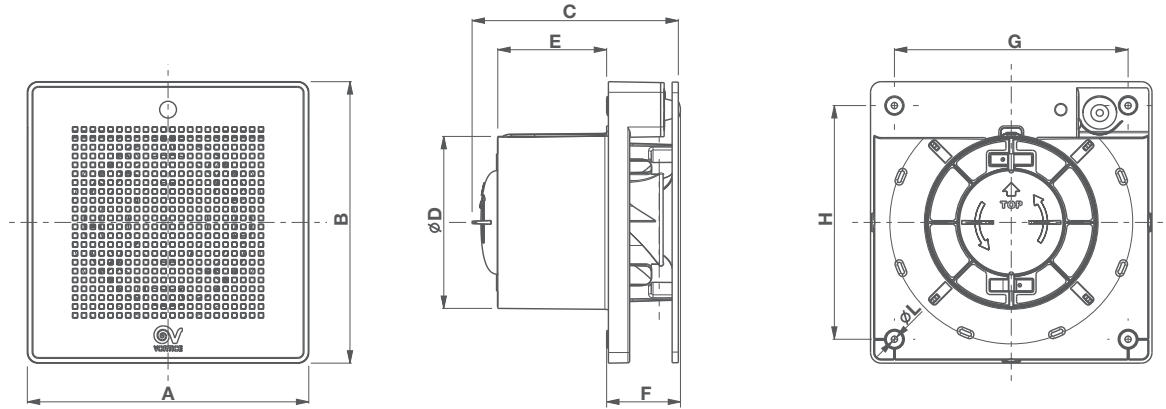

Models	A	B	C	Ø D	E	F	G	H	Ø L
ME 100/4'' LL	159	159	116.5	98	61.5	40.5	132	132	3.5

Dimensions (mm)

PERFORMANCE CURVES

ME 100/4'' cod. 11306 - 11307 - 11308 - 11309
11316 - 11317 - 11308 - 11319

POWER CONSUMPTION
— max
— min

PERFORMANCE CURVES
— max
— min

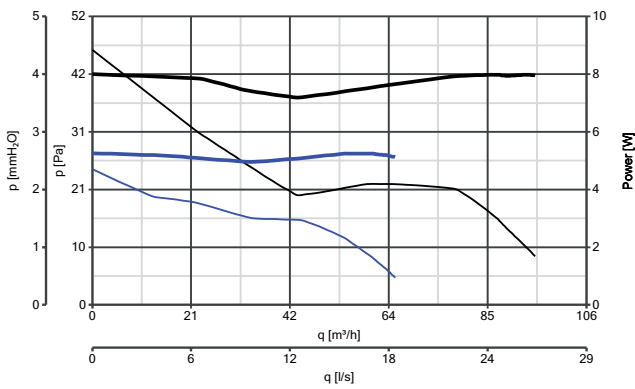

APPLICATIONS





Design: F. Trabucco & Associates



VORTICE VARIO RANGE

Wall/window axial fans **LONG LIFE 30.000 h**

PRODUCT SPECIFICATIONS

Supply to improve the quality of air we breathe daily in any domestic or commercial environment: dwellings, shops & cafes, sports centers gyms, restaurants, public houses, offices, schools, community halls and many more...

- **10 models:** from 150 to 300 diameter, long life, Pull Cord and automatic reversible.
- The Vortice Vario models are among the best of their category in terms of performance and low energy consumption thanks to highly efficient impellers.
- Structural components in UV resistant ABS, internal components from shock resistant PS.
- Quick and easy to install.
- Extremely low noise emission.
- Vario fans are carefully designed to provide a low environmental impact, using recyclable materials and following the new "Design for Disassembly" technique to provide easy and environmentally friendly disposal of components.
- Data and performances IMQ Performance certified
- Protection rating: IPX4.
- Insulation class: II □ .

TECHNICAL DATA

Models	Code	V ~ 50/60 Hz	W	A	RPM	Max Airflow		Lp dB(A) 3 m	Max °C	Kg
						m³/h	l/s			
VORTICE 150/6" AR	12612	220 - 240	25	0.11	1340 ⁽²⁾ 2040 ⁽¹⁾	235 ⁽²⁾ 150 ⁽¹⁾	65.3 ⁽²⁾ 41.7*	37.5	50	2.07
VORTICE 150/6" AR LL S	12615		35	0.17	2110 ⁽²⁾ 2520 ⁽¹⁾	380 ⁽²⁾ 215 ⁽¹⁾	105.6 ⁽²⁾ 59.7 ⁽¹⁾	49.6		
VORTICE 150/6" P	12611		18	0.10	1340	235	65.3	37.5		
VORTICE 150/6" P LL S	12614		32	0.16	2110	380	105.6	46.9		
VORTICE 230/9" AR	12452		26	0.13	790 ⁽²⁾ 1080 ⁽¹⁾	480 ⁽²⁾ 310 ⁽¹⁾	133 ⁽²⁾ 86*	35.6	50 (50 Hz) 40 (60 Hz)	3.45
VORTICE 230/9" AR LL S	12455		35 (50 Hz) 40 (60 Hz)	0.19	1200 ⁽²⁾ 1300 ⁽¹⁾	700 ⁽²⁾ 370 ⁽¹⁾	194.4 ⁽²⁾ 102.8 ⁽¹⁾	43.6		
VORTICE 230/9" P	12451		22	0.10	790	480	133	35.6		
VORTICE 230/9" P LL S	12454		32 (50 Hz) 38 (60 Hz)	0.18	1200	700	194.4	43.6		
VORTICE 300/12" AR	12412		45	0.21	840 ⁽²⁾ 1085 ⁽¹⁾	1050 ⁽²⁾ 700 ⁽¹⁾	292 ⁽²⁾ 194.4 ⁽¹⁾	40.2	50 (50 Hz) 40 (60 Hz)	6.13
VORTICE 300/12" AR LL S	12415		75 (50 Hz) 90 (60 Hz)	0.41	1215 ⁽²⁾ 1280 ⁽¹⁾	1650 ⁽²⁾ 920 ⁽¹⁾	458.3 ⁽²⁾ 255.6 ⁽¹⁾	53.6		

⁽¹⁾ Intake - ⁽²⁾ Extract

Legend: P= Pull Cord, A= Automatic, R= Reversible, LL= Long Life, S= Performance boost.

DIMENSIONS

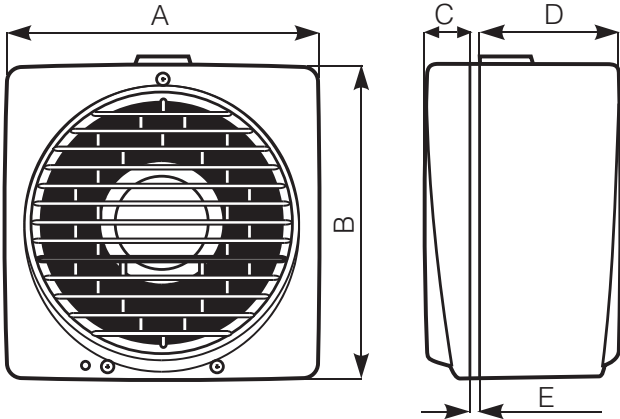

Models	A	B	C	D	E min/max	Hole dia Ø
VORTICE 150/6"	215	218	31	97.5	2/38	185÷190
VORTICE 230/9"	294	297		130		257÷262
VORTICE 300/12"	390	393		147		324÷329

Dimensions (mm)

PERFORMANCE CURVES

— Power consumption — Delivery

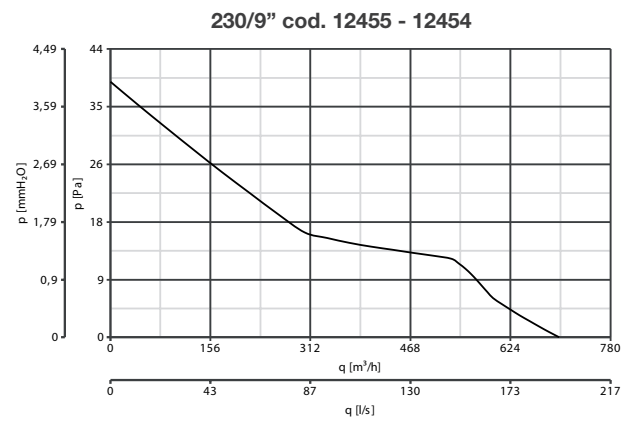
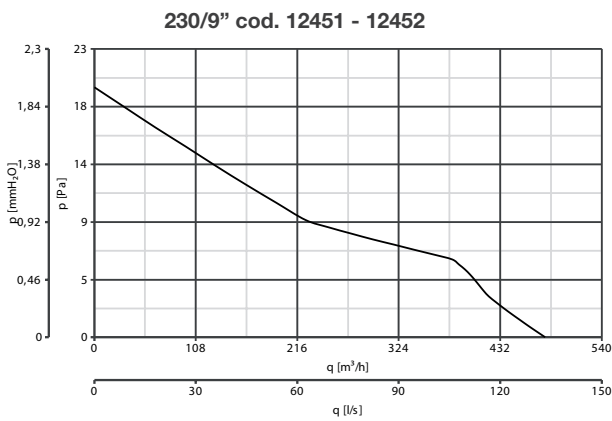
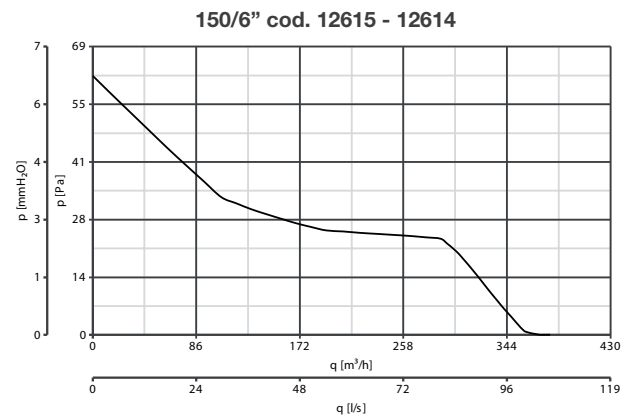
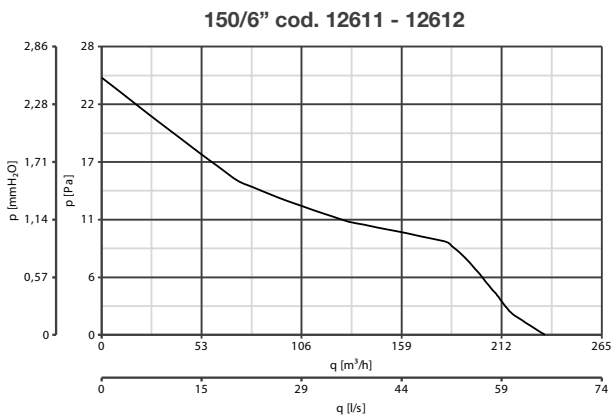

PERFORMANCE CURVES

— Power consumption — Delivery

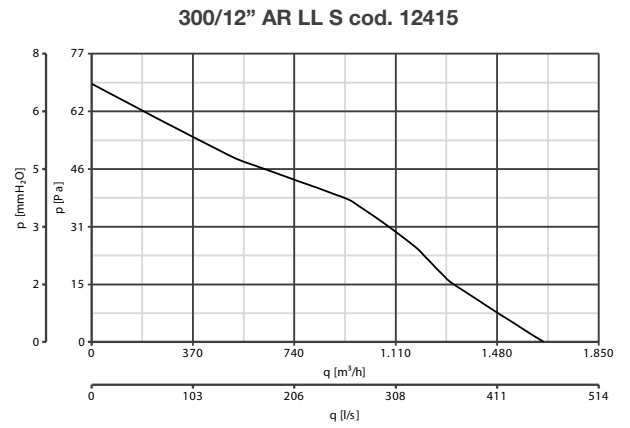
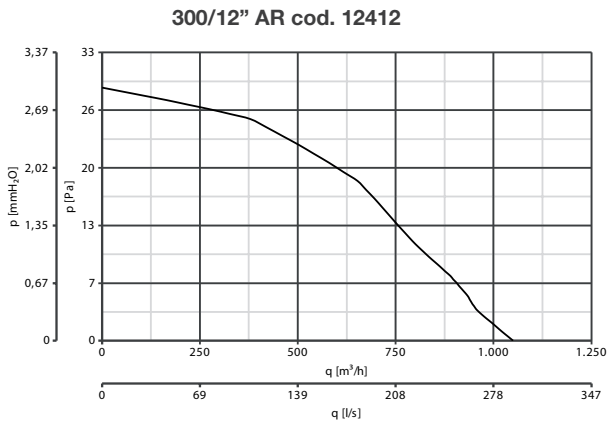

APPLICATIONS

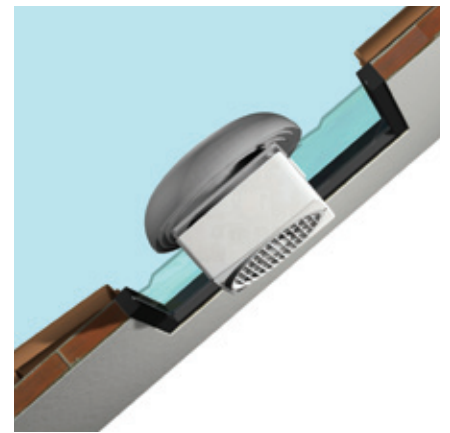



NOTE



Design: F. Trabucco & Associates



VORTICE VARIO I RANGE

Flush mounted axial fans **LONG LIFE 30.000 h**

PRODUCT SPECIFICATIONS

Supply to improve the quality of air we breathe daily in any domestic or commercial environment: dwellings, shops & cafes, sports centers gyms, restaurants, public houses, offices, schools, community halls and many more...

- **6 models:** from 150 to 300 diameters, Long life, Pull cord and automatic reversible.
- Flush mounting.
- The Vortice Vario models are among the best of their category in terms of performance and low energy consumption thanks to highly efficient impellers.
- Body made of shock-resistant ABS plastic anti-UV.
- Structural components in UV resistant ABS, internal components from shock resistant PS. Le giranti in polipropilene caricato con fibre di vetro.
- Quick and easy to install.
- Extremely low noise emission.
- Vario fans are carefully designed to provide a low environmental impact, using recyclable materials and following the new "Design for Disassembly" technique to provide easy and environmentally friendly disposal of components.
- Highly efficient impellers.
- Model for installation on glass/panel/wall.
- Ceiling installation and wall installation.
- Data and performances IMQ Performance certified.
- Protection rating: IPX4.
- Insulation class: II □ .

TECHNICAL DATA

Models	Code	V ~ 50/60 Hz	W	A	RPM	Max Airflow		Lp dB(A) 3 m	Max °C	Kg
						m³/h	l/s			
VORTICE 150/6" ARI	12613	220 - 240	25	0.11	1330 ⁽¹⁾ 1880 ⁽²⁾	220 ⁽¹⁾ 130 ⁽²⁾	61.1 ⁽¹⁾ 36.1 ⁽²⁾	38.2	50	2.52
VORTICE 150/6" ARI LL S	12616	220 - 240	35	0.17	2080 ⁽¹⁾ 2460 ⁽²⁾	350* 200**	97.2 ⁽¹⁾ 55.6 ⁽²⁾	49.1	50	
VORTICE 230/9" ARI	12453	220 - 240	26	0.13	810 ⁽¹⁾ 1080 ⁽²⁾	450 ⁽¹⁾ 300**	125 ⁽¹⁾ 83.3 ⁽²⁾	35.7	50	3.88
VORTICE 230/9" ARI LL S	12456	220 - 240	35 (50 Hz) 40 (60 Hz)	0.19	1160 ⁽¹⁾ 1260 ⁽²⁾	680 ⁽¹⁾ 350**	188.9 ⁽¹⁾ 97.2 ⁽²⁾	45.3	50	
VORTICE 300/12" ARI	12413	220- 240	45	0.21	850 ⁽¹⁾ 1150 ⁽²⁾	1200 ⁽¹⁾ 850 ⁽²⁾	333.3 ⁽¹⁾ 236.1 ⁽²⁾	40.7	50 (50 Hz) 40 (60 Hz)	7.20
VORTICE 300/12" ARI LL S	12416	220 - 240	75 (50 Hz) 90 (60 Hz)	0.41	1230 ⁽¹⁾ 1310 ⁽²⁾	1750 ⁽¹⁾ 1000 ⁽²⁾	486.1 ⁽¹⁾ 277.7 ⁽²⁾	53.5		

⁽¹⁾Extract - ⁽²⁾Intake

Legend: P= Pull Cord, A= Automatic, R= Reversible, LL= Long Life, S= Performance boost.

DIMENSIONS

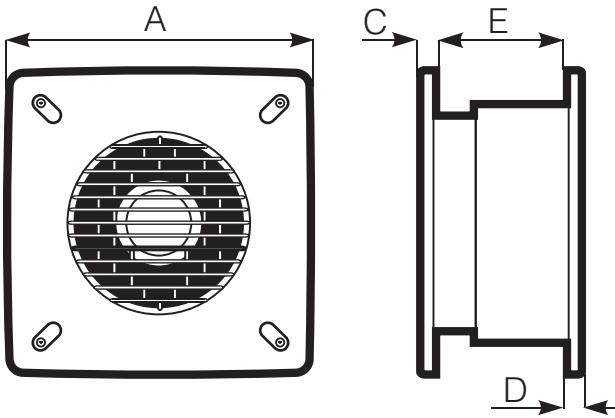

Models	∅ A	C	D	E	Hole dia ∅
VORTICE 150/6" ARI	300	9.5	10.5	135	260÷265
VORTICE 230/9" ARI	400	10	11	180	335÷340
VORTICE 300/12" ARI	495	10.5	11.5	210	435÷440

Dimensions (mm)

PERFORMANCE CURVES

— Power consumption — Delivery

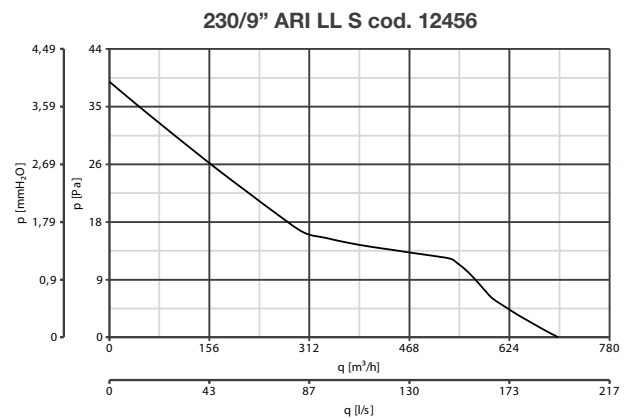
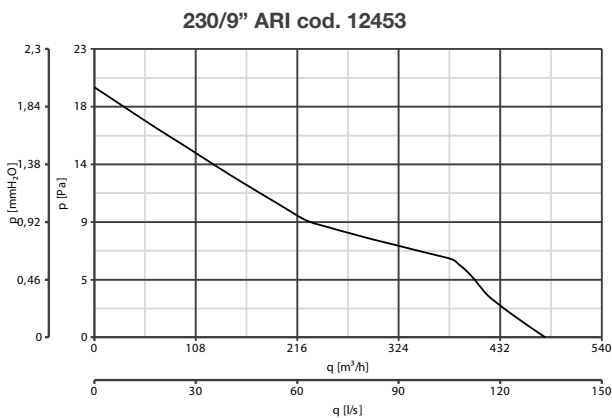
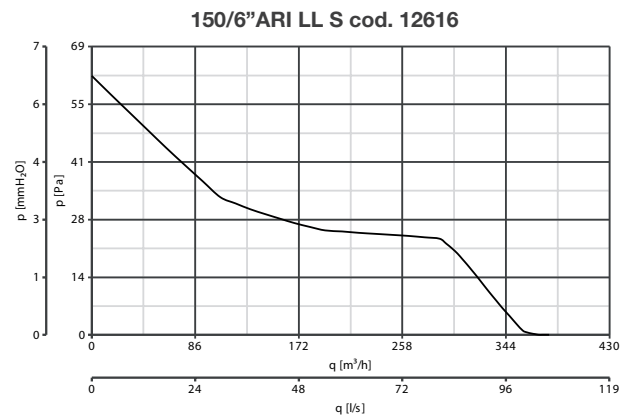
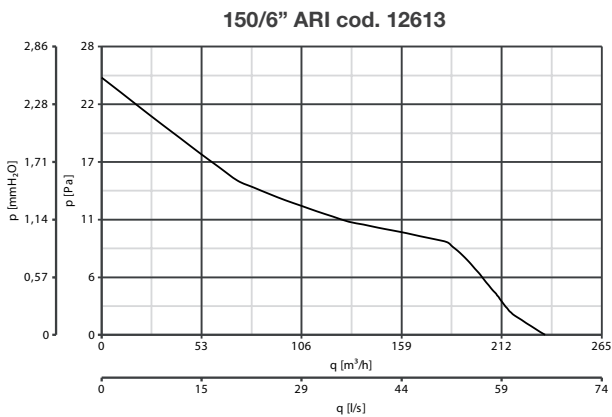

PERFORMANCE CURVES



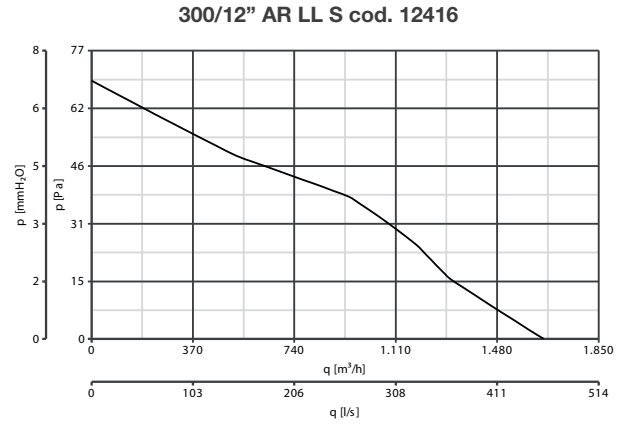
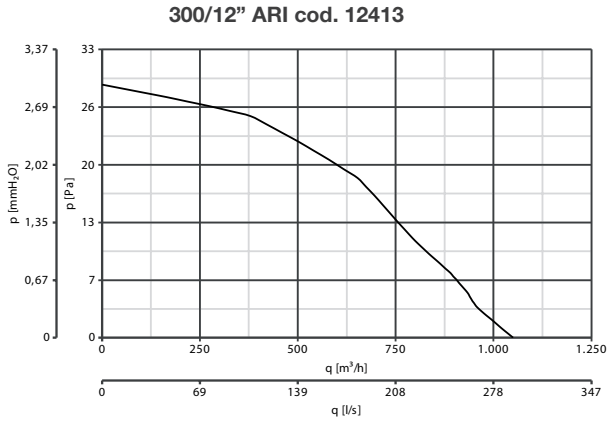



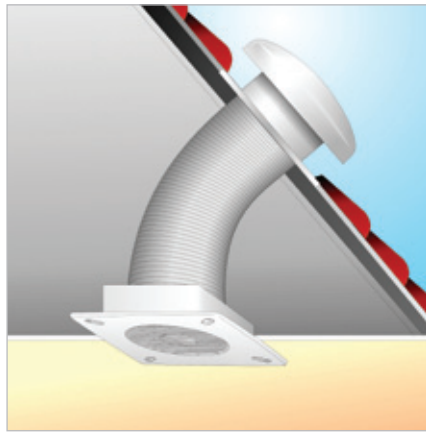



— Power consumption — Delivery



APPLICATIONS

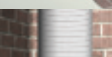

ACCESSORIES ON REQUEST

Models	Description	Code	Product	
	CR5 Reversible 5 speeds controller	12943	All products	
	CR5N Reversible 5 speeds controller	12941	All products (not for cod. 12611 - 12451)	
	CREN Reversible 5 speeds controller	12944		
	C Temp Environmental sensor for temperature	12992	All products	
	C SMOKE Environmental sensor for air quality	12993		
	C HCS Environmental sensor for humidity	12994		
	C PIR Passive infrared sensor	12998		
	C Timer Adjustable over-run timer	12999		
	KIT WV - Double opening window kit	150/6"	13021	12611 - 12612 -12615 - 12614
		230/9"	13022	12451 - 12452 - 12455 - 12454
		300/12"	13023	12412 - 12415
	KIT FF - Double opening window kit	150/6"	13024	12611 - 12612 -12615 - 12614
		230/9"	13025	12451 - 12452 - 12455 - 12454
		300/12"	13026	12412 - 12415
	KIT MU - Wall mounting kit with rods		13018	12611 - 12612 - 12451 - 12452 - 12454 - 12455 - 12412 - 12415 - 12615 - 12614
	KIT TE - Roof cowl/wind baffle kit	150/6"	13001	12611 - 12612 - 12614 - 12615
		230/9"	13002	12451 - 12452 - 12454 - 12455
		300/12"	13003	12412 - 12415
	KIT SA - Darkroom cowl kit		13004	12451 - 12452 - 12455 - 12613 - 12616 - 12653 - 12456 - 12413 - 12416
	KIT ML - Deep wall installation kit	150/6"	13015	12616 - 12653
		230/9"	13016	12456 - 12653
		300/12"	13017	12416 - 12413
	KIT SO - Ceiling, false ceiling and panel kit	150/6"	13012	12416 - 12456 - 12613 - 12653
		230/9"		
	KIT TC - Spigot plate remote application	150/6"	13027	12613 - 12616
		230/9"	13028	12456 - 12653
		300/12"	13029	12416 - 12413

Duct diameter for spigot plate

Models	Code	Ø D
150/6"	13027	171
230/9"	13028	240
300/12"	13029	300

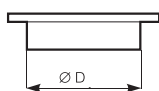
Duct diameter for flush mounting frame

Models	Code	Ø D
150/6"	13015	171
230/9"	13016	240
300/12"	13017	300

Diameter of PVC ducts

Models	Ø D int.	Ø D ext.	Thickness
150/6"	176	180	2
230/9"	245	250	2.5
300/12"	309	315	3

Diameter of aluminium ducts

Models	Ø D int.
150/6"	176
230/9"	245
300/12"	309



SINGLE AND DOUBLE-GLAZED WINDOW

Models	Kit required (1)(code)	Thickness min/max
150/6"	none	2÷38
230/9"		
300/12"		



KIT VV - DOUBLE-GLAZED (OPENING) WINDOW

Models	Kit required (2) (code)	Thickness min/max
150/6"	13021	30÷43
230/9"	13022	
300/12"	13023	



KIT FF - DOUBLE (OPENING) WINDOW SECONDARY-GLAZED

Models	Kit required (3) (code)	Thickness min/max
150/6"	13024	230÷300
230/9"	13025	
300/12"	13026	



KIT MU - WALL MOUNTING

Models	Kit required (4) (code)	Thickness max
150/6"	13018	300
230/9"		
300/12"		



WALL MOUNTING WITH EXTERNAL COWL AS A WIND BAFFLE

Models	Kit required (4) (code)	Thickness max
150/6"	13001+13018	300
230/9"	13002+13018	
300/12"	13003+13018	

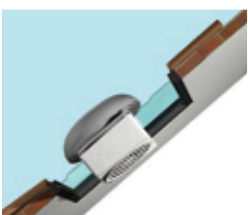

KIT TE - TORRETTA A VETRO O PANNELLO

Models	Kit required (code)
150/6"	13001
230/9"	13002
300/12"	13003



WINDOW/PANEL MOUNTING WITH EXTERNAL COWL AS A WIND BAFFLE

Models	Kit required (code)
150/6"	13001
230/9"	13002
300/12"	13003



WALL MOUNTING FOR REMOTE APPLICATION

Models	Kit required (code)
150/6"	13003 + 13018 + 2 items 13027
230/9"	13002 + 13018 + 2 items 13028
300/12"	13003 + 13018 + 2 items 13029

DUCT NOT INCLUDED



BUILT-IN WALL MOUNTING

Models	Kit required (5) (code)	Thickness
150/6"	none	135
230/9"		180
300/12"		210

BUILT-IN DEEP WALL MOUNTING

Models	Kit required (code)	Thickness min/max
150/6"	13015	260÷460
230/9"	13016	320÷500
300/12"	13017	375÷515



BUILT-IN PANEL, CEILING AND FALSE CEILING MOUNTING

Models	Kit required (code)
150/6"	13012
230/9"	
300/12"	13014

DUCT NOT INCLUDED



BUILT-IN WALL MOUNTED FOR REMOTE APPLICATION

Models	Kit required (code)
150/6"	13027+13012+13015
230/9"	13028+13012+13016
300/12"	13029+13014+13017

DUCT NOT INCLUDED

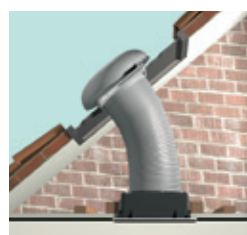

BUILT-IN ROOF MOUNTED FOR REMOTE APPLICATION

Models	Kit required (code)
150/6"	13001+13027+13012
230/9"	13002+13028+13012
300/12"	13003+13029+13014

DUCT NOT INCLUDED

(1) No kit is required for window/panels with thickness ranging from 3 to 38 mm.

(2) For installation in double-glazed (opening) window with thickness ranging from 30 to 43 mm.

(3) For installation on double (opening) window with thickness ranging from 230 to 300 mm.

(4) For installation on walls, with thickness ranging from 38 to 300 mm.

(5) No kit is required for walls with thickness ranging from 135 to 210 mm.

	Number of required kits	150/6" AR Code 12612	150/6" ARI LL S Code 12615	150/6" P Code 12611	150/6" P LL S Code 12614	230/9" AR Code 12452	230/9" ARI LL S Code 12455	230/9" P Code 12451	230/9" P LL S Code 12454	300/12" AR Code 12412	300/12" ARI LL S Code 12415	150/6" ARI Code 12613	150/6" ARI LL S Code 12616	230/9" ARI Code 12653	230/9" ARI LL S Code 12456	300/12" ARI Code 12413	300/12" ARI LL S Code 12416
Single-glazed window																	
Wall	1	13018	13018	13018	13018	13018	13018	13018	13018	13018	13018						
Double-glazed (opening) window	1	13021	13021	13021	13021	13022	13022	13022	13022	13022	13023						
Double (opening) window secondary-glazing	1	13024	13024	13024	13024	13025	13025	13025	13025	13025	13026						
Window-mounted with darkroom cowl	1					13004	13004	13004	13004								
Window / panel mounted with external cowl	1	13001	13001	13001	13001	13002	13002	13002	13002	13003	13003						
Roof application	1	13001	13001	13001	13001	13002	13002	13002	13002	13003	13003						
Wall-mounted with external cowl	2	13001 13018	13001 13018	13001 13018	13001 13018	13002 13018	13002 13018	13002 13018	13002 13018	13003 13018	13003 13018						
Wall-mounted for remote application (duct not included)	1	13001 13018 13027x2	13001 13018 13027x2	13001 13018 13027x2	13001 13018 13027x2	13002 13018 13027x2	13002 13018 13027x2	13002 13018 13027x2	13002 13018 13027x2	13003 13018 13027x2	13003 13018 13027x2						
Built-in wall mounted																	
Thin wall mounted for remote application (duct not included)	3	13001 13012 13018 13027	13001 13012 13018 13027	13001 13012 13018 13027	13001 13012 13018 13027	13002 13012 13018 13028	13002 13012 13018 13028	13002 13012 13018 13028	13002 13012 13018 13028	13003 13014 13018 13029	13003 13014 13018 13029						
Panel-mounted with darkroom cowl	1					13004	13004	13004	13004								
Wall-mounted with darkroom cowl	2					13018 13004	13018 13004	13018 13004	13018 13004								
Built-in deep wall mounted	1											13015	13015	13016	13016	13017	13017
Panel - Ceiling - False ceiling	1											13012	13012	13012	13012	13014	13014
Roof-mounted for remote application (duct not included)	3											13001 13027 13012	13001 13027 13012	13002 13028 13012	13002 13028 13012	13003 13029 13014	13003 13029 13014
Built-in wall mounted for remote application (duct not included)	3											13012 13015 13027	13012 13015 13027	13012 13016 13028	13012 13016 13028	13014 13017 13029	13014 13017 13029

TELESCOPIC FRAME FORWALL MOUNTED MODELS

This frame is made of expanded polystyrene and facilitates wall mounting of the Vortice Vario series. Accessory included.

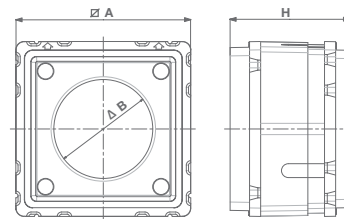
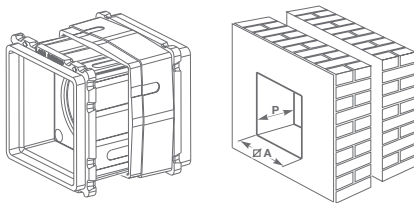

Models	∅ A	P (min)	P (max)
150/6"	325	220	330
230/9"	400	220	330
300/12"	500	220	330

Models	∅ A	∅ B	H
KIT IN 150/6"	315	180	205÷330
KIT IN 230/9"	390	260	205÷330
KIT IN 300/12"	490	305	205÷330

Dimensions (mm)



RESIDENTIAL VENTILATION

K RANGE

In-line centrifugal fans for kitchen cabinet

PRODUCT SPECIFICATIONS

Suitable for ventilation of up to two bathrooms or a single utility.

- **2 models.**
- Induction motor with thermal protection.
- Fan provides high air flow rate combined with pressures suitable for the application, when long ducts are used.
- The Axial K model also has directional flow to eliminate air turbulence.
- Two speeds (Angol K).
- Special anti-vibration gasket for silent operation.
- Protection grille on the intake port.
- Simplified internal and external maintenance and cleaning.
- Protection rating: IPX2.
- Insulation class: II □.

 **Awards**
1991 Italian Golden Compass
honor award



Design: F. Trabucco - M. Vecchi



TECHNICAL DATA

Models	Code	V ~ 50 Hz	W	A	RPM	Max Airflow		Max Pressure		Lp dB(A)* 3 m	Max °C	Kg
						m³/h	l/s	mmH₂O	Pa			
AXIAL K	10904	220 - 240	35	0.16	2560	135	37.5	17	167	41	40	1.20
ANGOL K	10204		40	0.12 0.20	1410 2180	86 140	23.9 38.9	13.5 17	132 157	33 43		1.27

* Data refers to both speeds. Measurement taken in front of the intake port with outlet connected and unobstructed extraction. Conforms with ISO 3744 for noise and pressure levels.

K RANGE | TECHNICAL DATA FOR REGULATION N° 1254/2014/UE

Models Code	Unit of measurement	AXIAL K 10904	ANGOL K 10204
Supplier's name or trade mark	-	Vortice	Vortice
Specific Energy Consumption class SEC in average climate zone	-	NA	NA
Specific Energy Consumption class SEC average	kWh/m ² a	-1,8	-2,2
Specific Energy Consumption class SEC cold		-10,5	-10,9
Specific Energy Consumption class SEC warm		10,5	10,1
Declared typology	-	RVU-U*	RVU-U*
Type of drive	-	NA	NA
Type of heat recovery system HRS	-	None	None
Thermal efficiency of heat recovery at reference air flow	%	NA	NA
Maximum flow rate	m ³ /s	78	75
Electric power input of the fan drive, including any motor control equipment, at maximum flow rate	W	27,0	29,2
Sound power level LWA	LWA [dB(A)]	64	62
Reference flow rate	m ³ /s	0,0152	0,0146
Reference pressure difference	Pa	129	82
SPI	W/(m ³ /h)	0,48901	0,47619
Control factor CTRL	%	1	1
Control typology	-	manual	manual
Maximum internal leakage rates	-	NA	NA
Maximum external leakage rates	%	NA	NA
Mixing rate	-	NA	NA
Position and description of visual filter warning	-	NA	NA
Airflow sensitivity to pressure variations at + 20 Pa and - 20 Pa	m ³ /h	NA	NA
Indoor/outdoor air tightness	-	NA	NA
Annual electricity consumption (AEC)	kWh electricity/a	613	597
AHS average Annual heating saved	kWh primary energy/a	1715	1715
AHS cold Annual heating saved		2732	2732
AHS warm Annual heating saved		632	632

* RVU-U: Unit Ventilation Residential - Unidirectional
 ** NRVU-U: Unit Ventilation Non Residential - Unidirectional
 *** MSD: Multi-Speed Drive

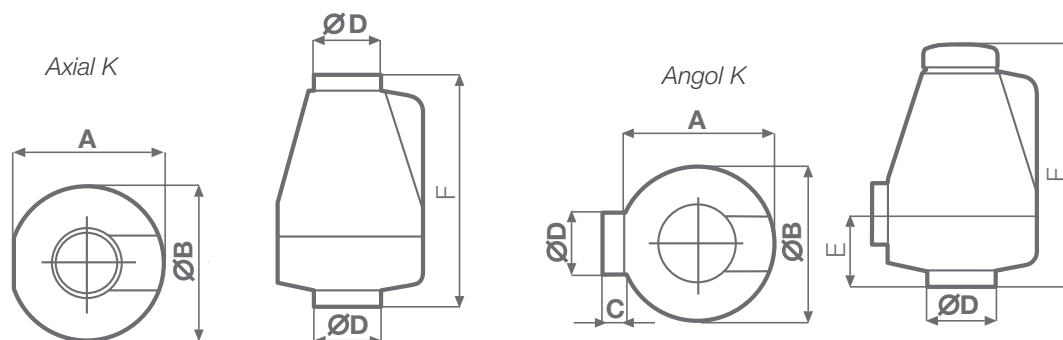
DIMENSIONS



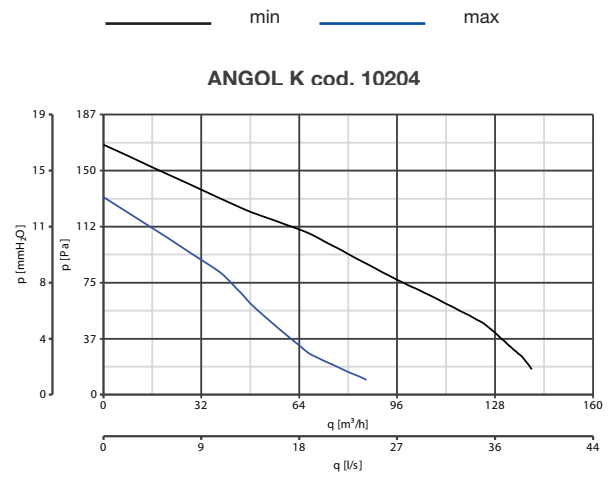
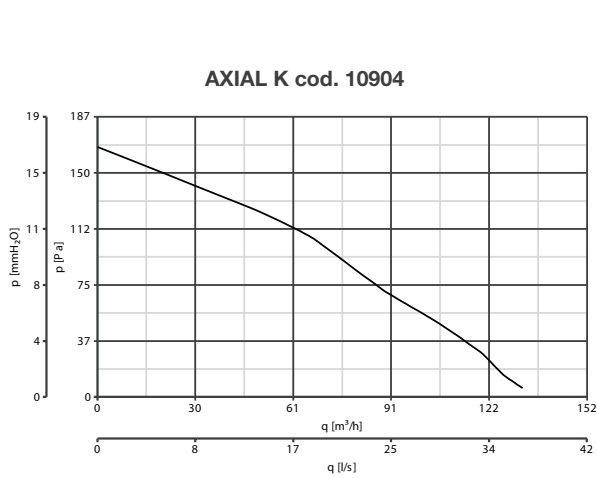

Models	Ø A	Ø B	C	Ø D	E	F
AXIAL K	168	176	-	97	-	270
ANGOL K			25		93	

Dimensions (mm)

PERFORMANCE CURVES



ACCESSORIES ON REQUEST

Models	Description	Code	Product
	C 1.5 Electronic speed controller 1.5 A	12966	All products
	SCNRB Electronic speed controller built-in	12971	
	SCB KIT Bult-in controller adaptor for C 1.5	22481	12966
	Air deflector	10/4	All products
	CA MU - Galvanized sheet-metal brackets	22674	

Accessories on request (description and technical data on page 146)

APPLICATIONS

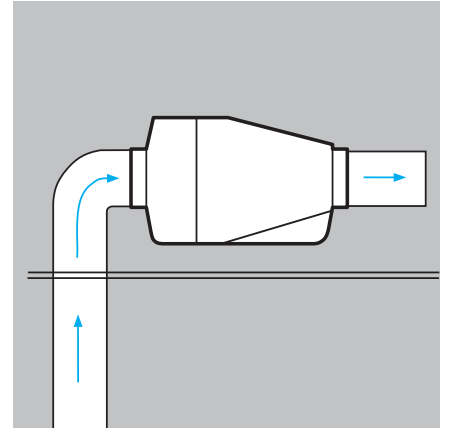
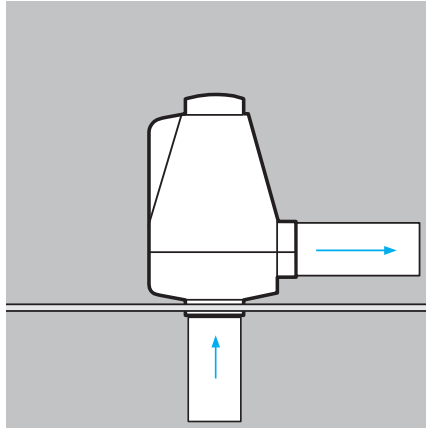
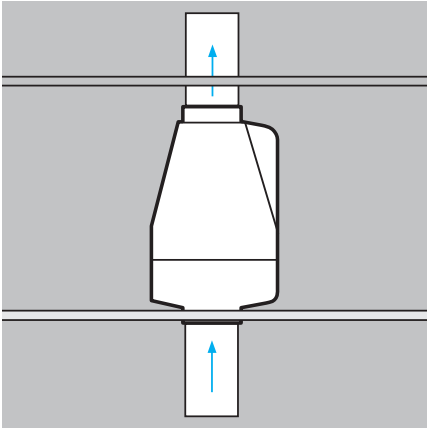



VORTEX® RANGE

Cooker hoods

PRODUCT SPECIFICATIONS

For ventilation of kitchens, these cooker hoods blend in well with any style of kitchen décor.

- **2 models:** 60 and 90 cm sizes. All models are supplied in extractor mode but can be converted to the recycling filtering mode using the optional kit.
- Supplied with self-illuminating, ergonomic buttons which allow selection of one of the three available speeds, according to the particular need.
- Excellent lighting with 40 W light bulbs and polycarbonate diffuser, ensures no alteration to the colour of food in the cooking area.
- Powerful yet silent, the low noise level at first speed is ideal when having to spend considerable time in the kitchen.
- Rugged construction with frame made of stainless-steel, coated in anti-scratch polyester-epoxy powder, motor-holder and fan made of self-extinguishing resin. Three-speed motor with Class B insulation and thermal cut-out for overheat protection.
- Filtering system: these models are equipped with a fabric grease filter.
- Complete with main fitting for 120 mm dia. duct and secondary fitting for 100 mm dia. duct, a cover with two discharge ports, activated-carbon filters for changing to the filtering type, air backdraught shutter, installation fixings, connection cable without plug.
- Insulation class: II .



TECHNICAL DATA

Models	Code	Colour	V ~ 50 Hz	W	Max Airflow		Max Pressure		Lp dB(A) 3 m min/max	Max °C	Kg
					m³/h min/max	l/s min/max	mmH ₂ O min/max	Pa min/max			
VORTEX 60	20021	W	220 240	160	120 150	33 69	12 21	118 210	37 56	40	8,5
	20022	I									
VORTEX 90	20023	W									
	20024	I									11

DIMENSIONS

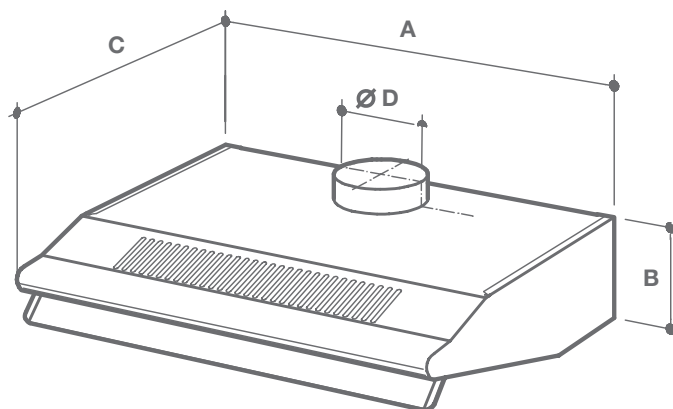

Models	A	B	C	Ø D
VORTEX 60	600	140	495	123
VORTEX 90	900			

Dimensions (mm)



ACCESSORIES ON REQUEST

Models	Description	Code	Product
VX-CB	Telescopic chimney - White	22116	20021 - 20024
VX-CI	Telescopic chimney - Stainless steel	22117	20022 - 20024
VX-FA 60	Fabric grease filter	22304	20021 - 20022
VX-FA 90	Fabric grease filter	22307	20023 - 20024
VX-FC 60	Activated carbon filter	22314	20021 - 20022
VX-FC 90	Activated carbon filter	22322	20023 - 20024



Design: F. Trabucco - M. Vecchi



VORT KAPPA

Centrifugal canopy fan

PRODUCT SPECIFICATIONS

For use when ventilating over a cooker in the kitchen.

- **1 model.**
- Automatic backdraught shutter to avoid back flow when unit is turned off.
- Two speeds.
- Metal body and motor-holder.
- Heat-resistant.
- Quick and easy installation and maintenance.
- Insulation class: I ⊕.
- Protection rating: IPX0.

Spare parts

- Metallic anti-dust filter.

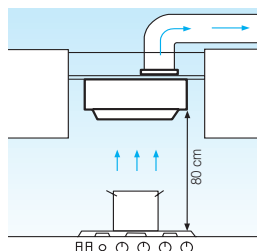

TECHNICAL DATA

Models	Code	V~50Hz min/max	W min/max	A min/max	RPM min/max	Max Airflow		Max Pressure		Lp dB(A)* 3 m min/max	Kg
						m³/h min/max	l/s min/max	mmH₂O min/max	Pa min/max		
VORT KAPPA	10950	220 - 240	50 90	0.29 0.44	850 1950	100 260	27,4 72,2	31 33	304 324	35.8 55.3	3,6

* Conforms with ISO 3744 for noise and pressure levels.

DIMENSIONS

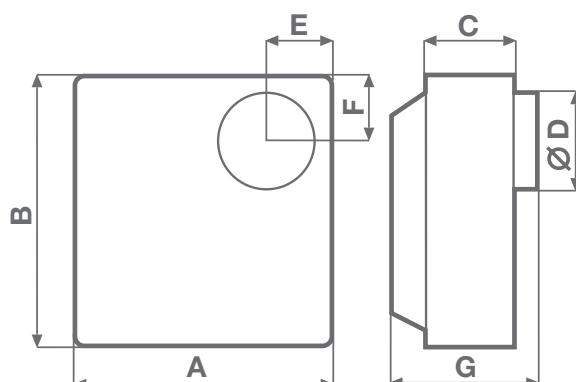

Models	A	B	C	Ø D	E	F	G
VORT KAPPA	252	270	90	97	65	65	145

Dimensions (mm)

PERFORMANCE CURVES

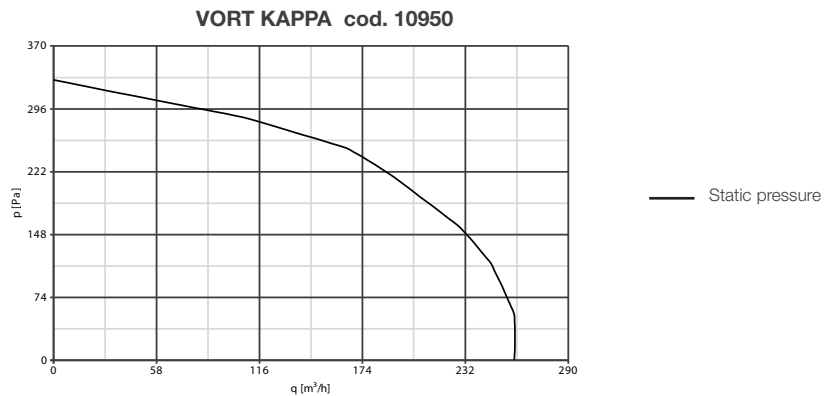

ACCESSORIES ON REQUEST

Models	Description	Code	Product	
	C 1.5 Electronic speed controller 1.5 A	12966	10950	
	SCNRB Electronic speed controller built-in	12971		
	SCB KIT Bult-in controller adaptor for C 1.5	22481	12966	
	Air deflector	10/4	22310	10950

Accessories on request (description and technical data on page 146)



Design: F. Trabucco - M. Vecchi



VORT MAX S

Centrifugal duct fans

PRODUCT SPECIFICATIONS

Suitable for ventilation of medium-sized or large rooms in commercial premises plus bathrooms/showers/toilets/utilities and kitchens in domestic situations.

- **1 model.**
- Motor with thermal cut-out incorporated in a closed-type motor-holder (protecting against dust and humidity).
- The units have a high extraction to overcome pressure loss when long ducts are used.
- The timer is adjustable from 3 to 20 min.
- Butterfly backdraught shutter to avoid air back-flow when the unit is turned off.
- Removable, washable protection grille and anti-dust filter.
- Vort Max comes with fittings for 100 and 120 mm dia. ducting.
- Data and performances IMQ Performance certified.
- Protection rating: IPX0.
- Insulation class: II □ .

TECHNICAL DATA

Models	Code	V~50Hz	W	A	RPM	Max Airflow		Max Pressure		Lp dB(A)* 3 m	Max °C	Kg
						m³/h	l/s	mmH ₂ O	Pa			
VORT MAX S	11970	220 - 240	80	0.37	2200	Ø 100:290 Ø 120:370	80.6 102.8	44	432	-	40	3

* Conforms with ISO 3744 for noise and pressure levels.

VORT MAX S | TECHNICAL DATA FOR REGULATION N° 1254/2014/UE

	Models Code	Unit of measurement	VORT MAX S 11970
Supplier's name or trade mark		-	Vortice
Declared typology		-	NRVU-U**
Type of drive			VSD***
Type of heat recovery system HRS		-	None
Thermal efficiency of heat recovery		-	NA
Nominal NRVU flow rate		m ³ /s	0,05521
Effective electric power input		kW	0,065
SFPint		W/(m ³ /h)	NA
Face velocity at design flow rate		m/s	7,02899
Nominal external pressure ($\Delta p_{s,int}$)		Pa	196
Internal pressure drop of ventilation components ($\Delta p_{s,int}$)		Pa	19
Internal pressure drop of non-ventilation components ($\Delta p_{s,int}$)		Pa	0
Static efficiency of fans used in accordance with Regulation (EU) N. 3272011		%	18,3
Declared maximum internal leakage rate of the casing of ventilation units		%	NA
Declared maximum external leakage rate of the casing of ventilation units		%	NA
Energy performance energy or classification of the filters		-	NA
Description of visual filter warning		%	NA
Casing sound power level (LWA)		dB(A)	58

* RVU-U: Unit Ventilation Residential - Unidirectional
 ** NRVU-U: Unit Ventilation Non Residential - Unidirectional
 *** VSD: Variable-Speed Drive

DIMENSIONS

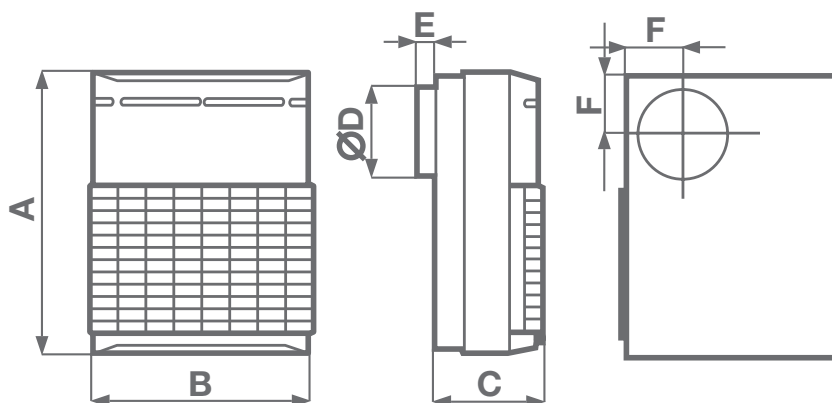

Models	A	B	C	Ø D	E	F
VORT MAX S	406	305	305	100 120		75

Dimensions (mm)

MAIN COMPONENTS

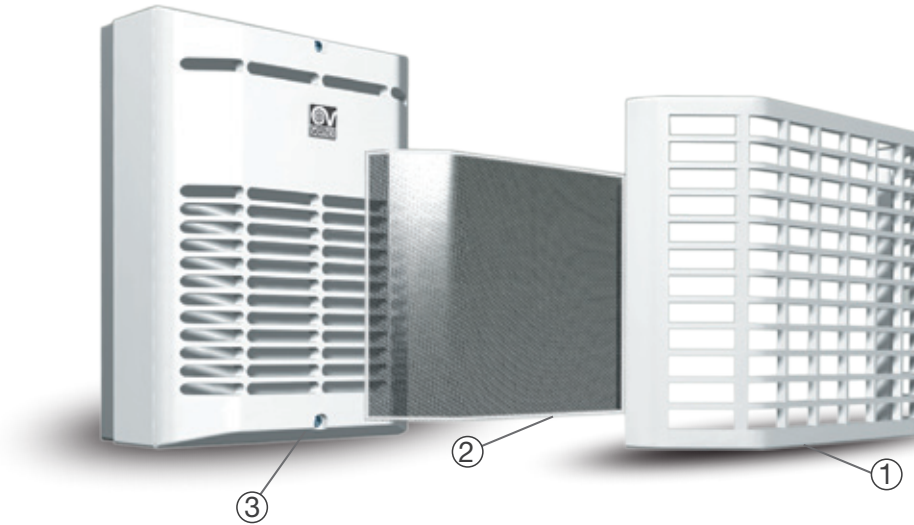

- ① Outer protection grille.
- ② Metallic filter which can be removed and washed (dishwasher safe) (available on LL version models only).
- ③ Made of rigid synthetic resin to guarantee high durability.

PERFORMANCE CURVES

VORT MAX S cod. 11970

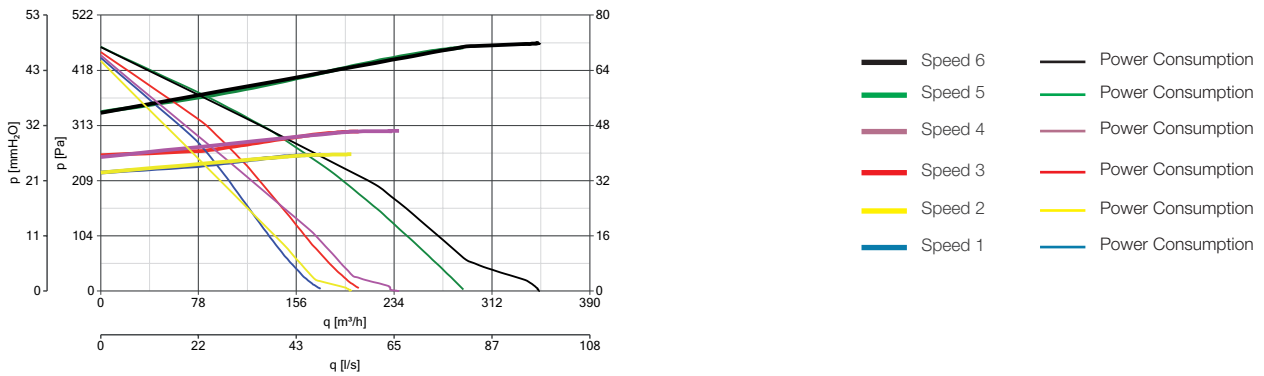

ACCESSORIES ON REQUEST

Models	Description	Code	Product
	C 1.5 Electronic speed controller 1.5 A	12966	11970
	SCNRB Electronic speed controller built-in	12971	
	SCB KIT Bult-in controller adaptor for C 1.5	22481	12966
	Air deflector	10/4	11970
		12/5	

Accessories on request (description and technical data on page 146)

APPLICATIONS





Design: F. Trabucco - M. Vecchi



ARIETT RANGE

Centrifugal duct fans **LONG LIFE 30.000 h**

PRODUCT SPECIFICATIONS

For the ventilation of areas with intermittent use (small bathrooms, private or public toilets).

- **2 models.**
- Motor with shielded poles and ball bearings (guaranteed for 30,000 fault-free hours of operation) and thermal overload protection.
- Double motor-fan housing, antivibration supports and backdraught shutter for silent operation.
- The timer is adjustable from 3 to 20 min.
- Pir model, checks for human motion in the room: the extractor fan is activated automatically when human movement is detected in its range.
- T-HCS model, adjustable RH threshold at 60%, 70%, 80%, 90% by mean of a slide switch during installation. †The product automatically switches on when the indoor relative humidity level exceeds the pre-set value.
- 100 mm dia. outlet spigot.
- Data and performances IMQ Performance certified.
- Protection rating: IPX4.
- Insulation class: II □ .

TECHNICAL DATA

Models	Code		V~50Hz	W	A	RPM	Max Airflow		Max Pressure		Lp dB(A)* 3 m	Max °C	Kg
	Basic	Timer					m³/h	l/s	mmH₂O	Pa			
ARIETT LL	11965	11966	230	18	0.14	2315	70	19.4	12	118	40	40	1.50

* Conforms with ISO 3744 for noise and pressure levels.

ARIETT RANGE | TECHNICAL DATA FOR REGULATION N° 1254/2014/UE

	Models Code	Unit of measurement	ARIETT LL - ARIETT LL T 11965 - 11966
Supplier's name or trade mark		-	Vortice
Specific Energy Consumption class SEC in average climate zone		-	NA
Specific Energy Consumption class SEC average			-5,5
Specific Energy Consumption class SEC cold		kWh/m ² a	-18,9
Specific Energy Consumption class SEC warm			-2,1
Declared typology		-	RVU-U*
Type of drive		-	NA
Type of heat recovery system HRS		-	None
Thermal efficiency of heat recovery at reference air flow		%	NA
Maximum flow rate		m ³ /s	71
Electric power input of the fan drive, including any motor control equipment, at maximum flow rate		W	13,7
Sound power level LWA		LWA [dB(A)]	61
Reference flow rate		m ³ /s	0,0138
Reference pressure difference		Pa	77
SPI		W/(m ³ /h)	0,24547
Control factor CTRL		%	1
Control typology		-	manual
Maximum internal leakage rates		-	NA
Maximum external leakage rates		%	NA
Mixing rate		-	NA
Position and description of visual filter warning		-	NA
Airflow sensitivity to pressure variations at + 20 Pa and - 20 Pa		m ³ /h	NA
Indoor/outdoor air tightness		-	NA
Annual electricity consumption (AEC)		kWh electricity/a	338
AHS average Annual heating saved		kWh primary energy/a	1397
AHS cold Annual heating saved			2732
AHS warm Annual heating saved			632

* RVU-U: Unit Ventilation Residential - Unidirectional

** NRUVU-U: Unit Ventilation Non Residential - Unidirectional

*** MSD: Multi-Speed Drive

DIMENSIONS

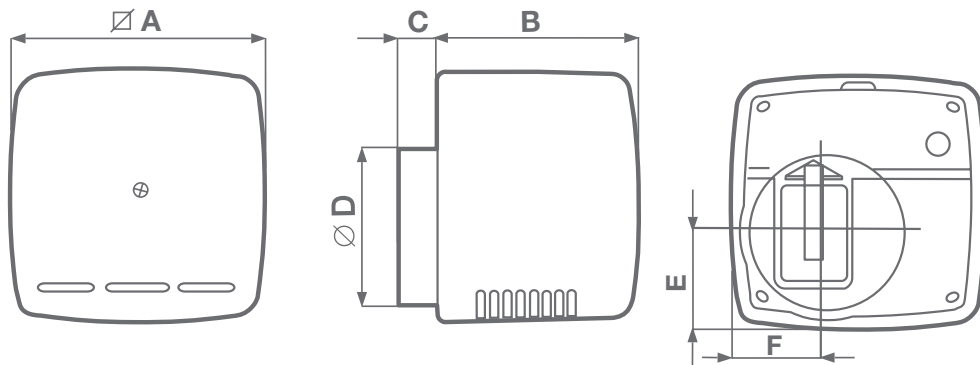

Models	∅ A	B	C	∅ D	E	F
ARIETT LL	156	123	25	97	60	60



Dimensions (mm)

PERFORMANCE CURVES

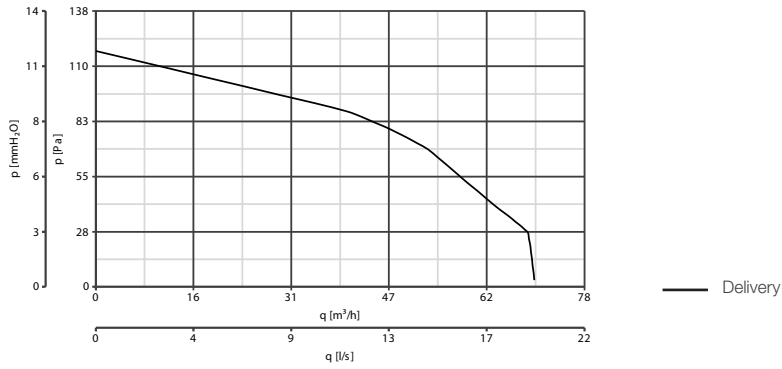
ARIETT LL cod. 11965 - 11966



ACCESSORIES ON REQUEST

Models	Description	Code	Product
	C 1.5 Electronic speed controller 1.5 A	12966	11965
	SCNRB Electronic speed controller built-in	12971	
	SCB KIT Bult-in controller adaptor for C 1.5	22481	12966
	Air deflector	10/4 22310	All products

Accessories on request (description and technical data on page 146)

APPLICATIONS





Design: F. Trabucco & Associates



ARIETT I RANGE

Centrifugal duct fans for flush mounting **LONG LIFE 30.000 h**

PRODUCT SPECIFICATIONS

Suitable for use in bathrooms, shower rooms and toilets.

- **2 models:** basic and timer version.
- Two speeds.
- Motor with shielded poles and ball bearings (guaranteed for 30,000 fault-free hours of operation) and thermal overload protection.
- Double motor-fan housing, antivibration supports and backdraught shutter for silent operation.
- Unobtrusive front grille.
- Support springs for the front grille, suitable for 65 mm max false ceilings.
- Metallic filter which can be removed and washed (dishwasher safe).
- Vertical or horizontal extract points.
- All fans have the optional side or rear exit low profile connector, or high profile connector.
- Backdraught-shutter to avoid back-flow when unit is turned off.
- Timer models, the timer is adjustable from 3 to 20 min.
- The fans meet all necessary requirement of F1 building regulations.
- Data and performances IMQ Performance certified.
- Protection rating: IPX4.
- Insulation class: II □.

TECHNICAL DATA

Models	Code		V~50Hz	W	A	RPM	Max Airflow		Max Pressure		Lp dB(A)* 3 m	Max °C	Kg
	Basic	Timer					m³/h	l/s	mmH ₂ O	Pa			
ARIETT LL I	12010	12011	230	19	0.13	2360 ⁽¹⁾ 2460 ⁽²⁾	80 ⁽¹⁾ 70 ⁽²⁾	22.2 ⁽¹⁾ 19.4 ⁽²⁾	11	108	40	40	1.9

⁽¹⁾Rear air outlet. ⁽²⁾Side air outlet with high profile.

ARIETT I RANGE | TECHNICAL DATA FOR REGULATION N° 1254/2014/UE

	Models Code	Unit of measurement	ARIETT LL I - ARIETT LL I T 12010 - 12011
Supplier's name or trade mark		-	Vortice
Specific Energy Consumption class SEC in average climate zone		-	NA
Specific Energy Consumption class SEC average		kWh/m²a	-5,3
Specific Energy Consumption class SEC cold			-18,6
Specific Energy Consumption class SEC warm			-2,4
Declared typology		-	RVU-U*
Type of drive		-	NA
Type of heat recovery system HRS		-	None
Thermal efficiency of heat recovery at reference air flow		%	NA
Maximum flow rate		m³/s	72
Electric power input of the fan drive, including any motor control equipment, at maximum flow rate		W	13,5
Sound power level LWA		LWA [dB(A)]	64
Reference flow rate		m³/s	0,0140
Reference pressure difference		Pa	72
SPI		W/(m³/h)	0,25198
Control factor CTRL		%	1
Control typology		-	manual
Maximum internal leakage rates		-	NA
Maximum external leakage rates		%	NA
Mixing rate		-	NA
Position and description of visual filter warning		-	NA
Airflow sensitivity to pressure variations at + 20 Pa and - 20 Pa		m³/h	NA
Indoor/outdoor air tightness		-	NA
Annual electricity consumption (AEC)		kWh electricity/a	347
AHS average Annual heating saved		kWh primary energy/a	1397
AHS cold Annual heating saved			2732
AHS warm Annual heating saved			632

* RVU-U: Unit Ventilation Residential - Unidirectional

** NRVU-U: Unit Ventilation Non Residential - Unidirectional

*** MSD: Multi-Speed Drive

DIMENSIONS

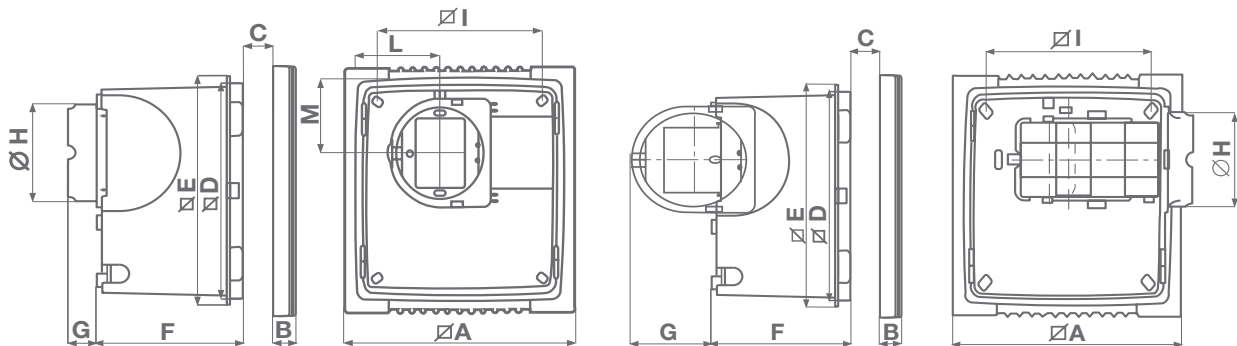

Models	∅ A	B	C	∅ D	∅ E	F	G	∅ H	∅ I	L	M
ARIETT LL I	252	23	65	214.5	228	135.3	31.5/ 76.7	96.5	180	92	76

Dimnesions (mm)

MAIN COMPONENTS

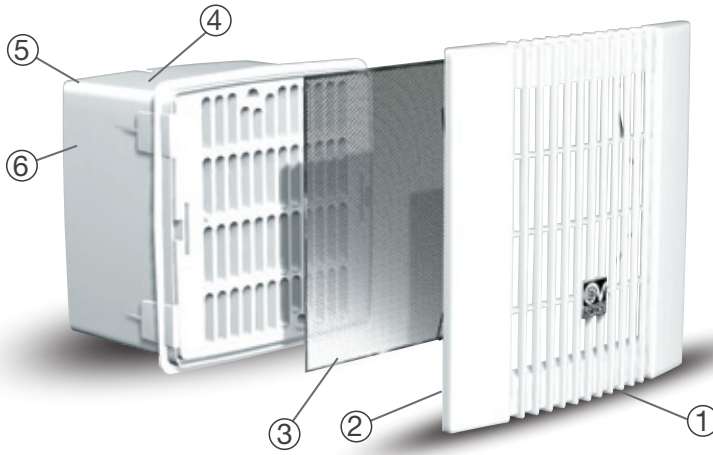

- ① Unobtrusive front grille.
- ② Support springs for the front grille, suitable for 65 mm max false ceilings.
- ③ Metallic filter which can be removed and washed (dishwasher safe) (available on LL version models only).
- ④ Made of rigid synthetic resin to guarantee high durability.
- ⑤ 100 mm dia. Outlet spigot which can be positioned to the rear or side (using optional accessories).
- ⑥ Backdraught-shutter to avoid back-flow when unit is turned off.

PERFORMANCE CURVES

ARIETT LL I cod. 12010 - 12011

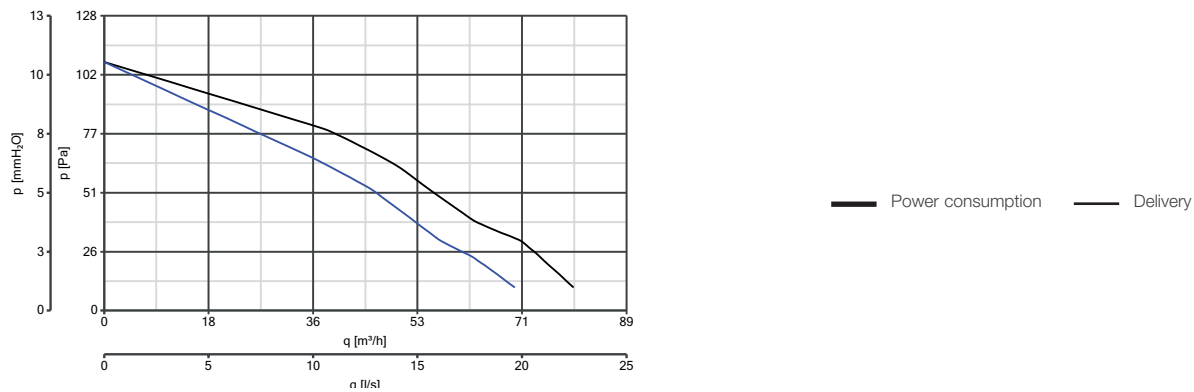

ACCESSORIES ON REQUEST

Models	Description	Code	Product	
	C 1.5 Electronic speed controller 1.5 A	12966	12010	
	SCNRB Electronic speed controller built-in	12971		
	SCB KIT Bult-in controller adaptor for C 1.5	22481	12966	
	Air deflector	10/4	22310	All products
	High profile connector		22841	
	False-ceiling/wall installation kit		22823	
	Horizontal Outlet - Low Profile		22842	All Products
	Horizontal Outlet - High Profile		22823	All Products

Accessories on request (description and technical data on page 146)

APPLICATIONS

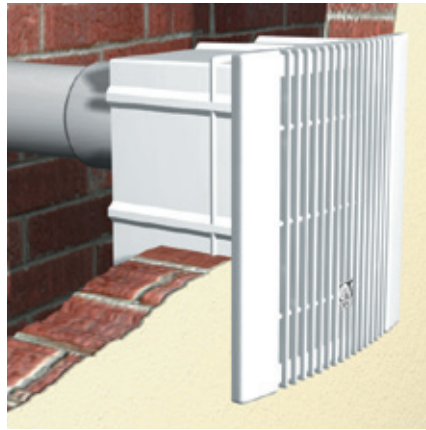
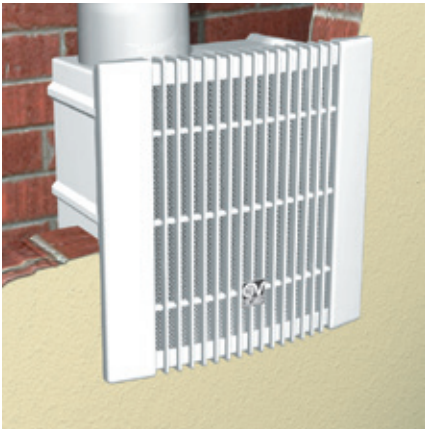



ARIETT HABITAT RANGE

Centrifugal duct fans **LONG LIFE 30.000 h**

PRODUCT SPECIFICATIONS

For continuous ventilation, with boost facility. Ideal for use in public sector housing in bathrooms, showers, utilities and toilets.

- **2 models:** Habitat 15/30 can be used to provide trickle ventilation for rooms housing open-flued combustion appliances.
- Two speeds.
- Motor with shielded poles and ball bearings (guaranteed for 30,000 fault-free hours of operation) and thermal overload protection.
- Low power consumption.
- Fully comply with F1 Building Regulations, plus 1.9D alternative approaches.
- Antivibration support gasket, used for mounting on tiled or uneven walls.
- Backdraught-shutter to avoid back flow when unit is turned off.
- Available only for model 15/30.
- 100 mm dia. outlet spigot.
- Complete with fixings.
- Protection rating: IPX4.
- Insulation class: II □.

Design: F. Trabucco & Associates



TECHNICAL DATA

Models	Code	V~50Hz	W min/max	A min/max	RPM min/max	Max Airflow		Max Pressure		Lp dB(A)* 3 m min/max	Max °C	Kg
						m³/h min/max	l/s min/max	mmH₂O min/max	Pa min/max			
ARIETT HABITAT LL 15/30	12000	230	5 - 8	0.02 - 0.04	1260 - 1870	20 - 43	5.6 - 11.9	8 - 10	78 - 98	30 - 41.5	40	1.20
ARIETT HABITAT LL 20/75	12001		6 - 25	0.03 - 0.17	890 - 2470	27 - 85	7.5 - 23.6	8 - 12	78 - 118	30.5 - 51	40	1.4

* Conforms with ISO 3744 for noise and pressure levels.

ARIETT HABITAT SERIE | TECHNICAL DATA FOR REGULATION N° 1254/2014/UE

	Models Code	Unit of measurement	ARIETT HABITAT LL 15/30	ARIETT HABITAT LL 27/75
			12000	12001
Supplier's name or trade mark	-	-	Vortice	Vortice
Specific Energy Consumption class SEC in average climate zone	-	-	NA	NA
Specific Energy Consumption class SEC average	kWh/m ² a	-	-4,2	0,2
Specific Energy Consumption class SEC cold		-	-17,6	-13,2
Specific Energy Consumption class SEC warm		-	3,5	7,8
Declared typology	-	-	RVU-U*	RVU-U*
Type of drive	-	-	NA	NA
Type of heat recovery system HRS	-	-	None	None
Thermal efficiency of heat recovery at reference air flow	%	-	NA	NA
Maximum flow rate	m ³ /s	-	39	74
Electric power input of the fan drive, including any motor control equipment, at maximum flow rate	W	-	8,2	22,8
Sound power level LWA	LWA [dB(A)]	-	53	62
Reference flow rate	m ³ /s	-	0,0076	0,41120
Reference pressure difference	Pa	-	60	73
SPI	W/(m ³ /h)	-	0,28353	0,41120
Control factor CTRL	%	-	1	1
Control typology	-	-	manual	manual
Maximum internal leakage rates	-	-	NA	NA
Maximum external leakage rates	%	-	NA	NA
Mixing rate	-	-	NA	NA
Position and description of visual filter warning	-	-	NA	NA
Airflow sensitivity to pressure variations at + 20 Pa and - 20 Pa	m ³ /h	-	NA	NA
Indoor/outdoor air tightness	-	-	NA	NA
Annual electricity consumption (AEC)	kWh electricity/a	-	391	567
AHS average Annual heating saved	kWh primary energy/a	-	1397	1397
AHS cold Annual heating saved		-	2732	2732
AHS warm Annual heating saved		-	632	632

* RVU-U: Unit Ventilation Residential - Unidirectional

** NRUVU-U: Unit Ventilation Non Residential - Unidirectional

*** MSD: Multi-Speed Drive

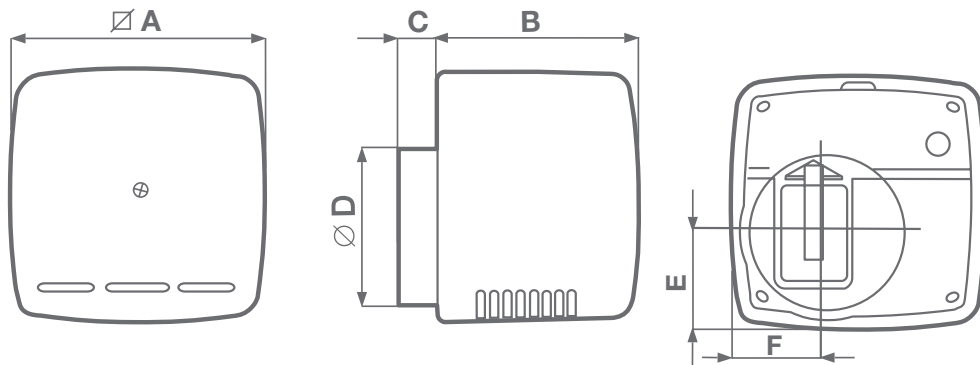
DIMENSIONS

Models	∅ A	B	C	∅ D	E	F
ARIETT LL	156	123	25	97	60	60

Dimensions (mm)

PERFORMANCE CURVES

— min — max

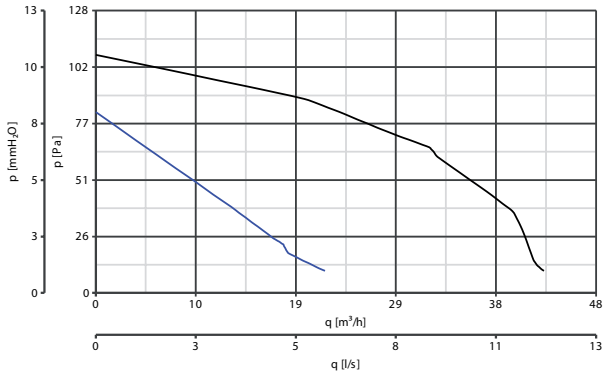

ARIETT HABITAT LL 15/30 cod. 12000

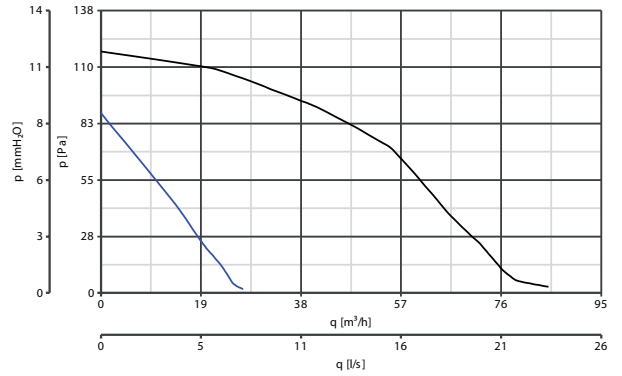

ARIETT HABITAT LL 20/75 cod. 12001



ACCESSORIES ON REQUEST

Models	Description	Code	Product	
	C 1.5 Electronic speed controller 1.5 A	12966	12000	
	SCNRB Electronic speed controller built-in	12971		
	SCB KIT Built-in controller adaptor for C 1.5	22481	12966	
	Air deflector	10/4	22310	All products
	Horizontal Outlet - Low Profile		22842	All Products
	Horizontal Outlet - High Profile		22823	All Products

Accessories on request (description and technical data on page 146)

APPLICATIONS





Design: F. Trabucco - M. Vecchi



VORT PRESS RANGE

Centrifugal duct fans **LONG LIFE 30.000 h**

PRODUCT SPECIFICATIONS

For the ventilation of medium-sized rooms in commercial applications plus bathrooms, showers, toilets, utilities in domestic situations.

- **4 models**, with or without timer.
- Double motor-fan housing, antivibration supports and backdraught shutter for silent operation.
- Two speeds.
- Motor with ball bearings (guaranteed 30,000 hours of continuous operation) with thermal cut-out.
- Metallic filter which can be removed and washed (dishwasher safe).
- 100 mm dia. outlet spigot.
- Backdraught-shutter to avoid back flow when unit is turned off.
- "Intelligent" timer turns the unit on for approximately 40 sec. after the activation. When switched off, the unit continues to operate at the minimum speed for between 30 sec. and 30 min. (depending on the setting).
- Data and performances IMQ Performance certified.
- Protection rating: IPX4.
- Insulation class: II □.

Spare Parts

- Metallic anti-dust filter.

TECHNICAL DATA

Models	Code		V~50Hz	W min/max	A min/max	RPM min/max	Max Airflow		Max Pressure		Lp dB(A)* 3 m min/max	Max °C	Kg
	basic	timer					m³/h min/max	l/s min/max	mmH₂O min/max	Pa min/max			
VORT PRESS 110 LL	11967	11968	220-240	12 24	0.07 0.22	925 1760	55 110	15.3 30.6	10 16	98 157	<30 41	40	1.95
VORT PRESS 220 LL	11977	11978		35 68	0.24 0.30	1200 2060	120 220	33.3 61.1	32 33	314 324	43 55		2.30

* Conforms with ISO 3744 for noise and pressure levels.

VORT PRESS RANGE | TECHNICAL DATA FOR REGULATION N° 1254/2014/UE

Models Code	Unit of measurement	ARIETT PRESS 110 LL 11967 - 11968
Supplier's name or trade mark	-	Vortice
Specific Energy Consumption class SEC in average climate zone	-	NA
Specific Energy Consumption class SEC average	kWh/m ² a	-2,7
Specific Energy Consumption class SEC cold		-16,0
Specific Energy Consumption class SEC warm		5,0
Declared typology	-	RVU-U*
Type of drive	-	NA
Type of heat recovery system HRS	-	None
Thermal efficiency of heat recovery at reference air flow	%	NA
Maximum flow rate	m ³ /s	109
Electric power input of the fan drive, including any motor control equipment, at maximum flow rate	W	29,0
Sound power level LWA	LWA [dB(A)]	62
Reference flow rate	m ³ /s	0,0212
Reference pressure difference	Pa	95
SPI	W/(m ³ /h)	0,32765
Control factor CTRL	%	1
Control typology	-	manual
Maximum internal leakage rates	-	NA
Maximum external leakage rates	%	NA
Mixing rate	-	NA
Position and description of visual filter warning	-	NA
Airflow sensitivity to pressure variations at + 20 Pa and - 20 Pa	m ³ /h	NA
Indoor/outdoor air tightness	-	NA
Annual electricity consumption (AEC)	kWh electricity/a	451
AHS average Annual heating saved	kWh primary energy/a	1397
AHS cold Annual heating saved		2732
AHS warm Annual heating saved		632

* RVU-U: Unit Ventilation Residential - Unidirectional

** NRVU-U: Unit Ventilation Non Residential - Unidirectional

*** MSD: Multi-Speed Drive

DIMENSIONS

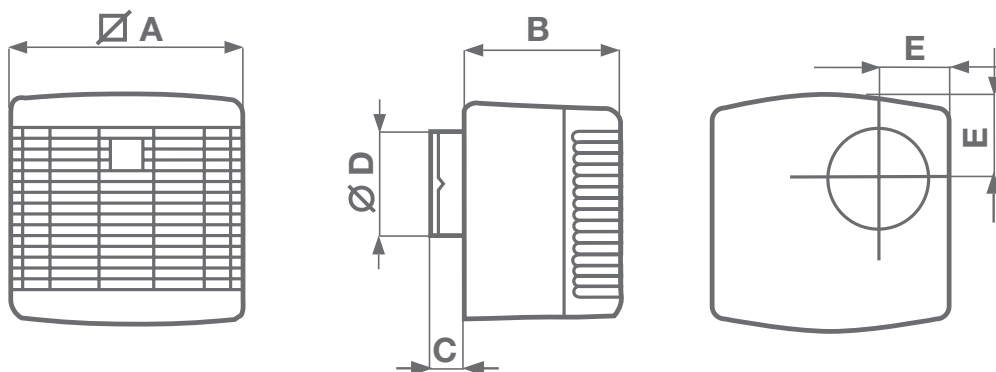

Models	∅ A	B	C	∅ D	E
VORT PRESS 110 LL	202	147	30	97	73
VORT PRESS 220 LL	275	140	28		

Dimensions (mm)

MAIN COMPONENTS

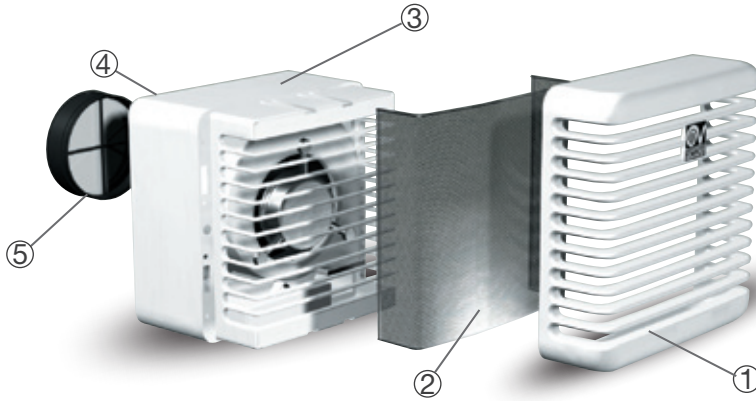

- ① Front grille.
- ② Metallic filter which can be removed and washed (dishwasher safe).
- ③ Made of rigid synthetic resin to guarantee high durability.
- ④ 100 mm dia. outlet spigot.
- ⑤ Silicon backdraught shutter to avoid back-flow when the unit is turned off.

PERFORMANCE CURVES

— Power consumption
— Performance curves

— Speed 1
— Speed 2

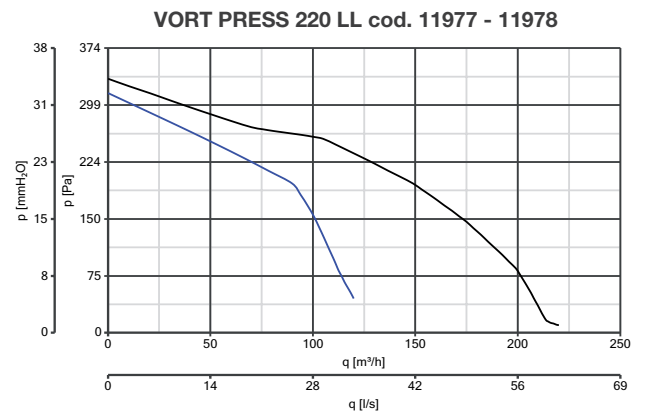
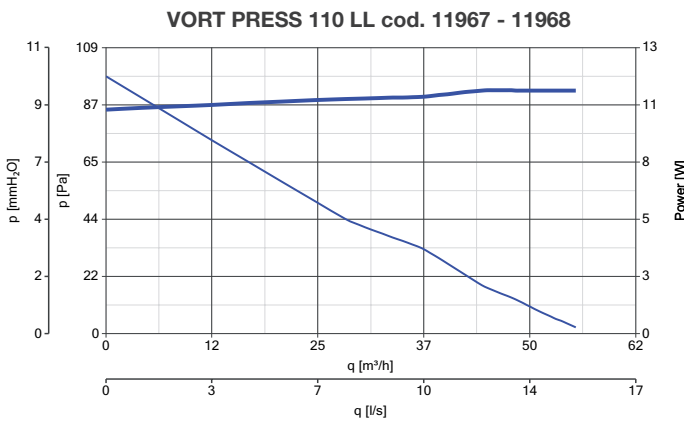

ACCESSORIES ON REQUEST

Models	Description	Code	Product	
	C 1.5 Electronic speed controller 1.5 A	12966	11967 - 11977	
	SCNRB Electronic speed controller built-in	12971		
	SCB KIT Built-in controller adaptor for C 1.5	22481	12966	
	Air deflector	10/4	22310	All products

Accessories on request (description and technical data on page 146)

APPLICATIONS





VORT PRESS I RANGE

Centrifugal duct fans for flush mounting **LONG LIFE 30.000 h**



Design: F. Trabucco & Associates (Vort Press I 110)
F. Trabucco - M. Vecchi (Vort Press I 140 /240)



PRODUCT SPECIFICATIONS

For the ventilation of medium-sized or large rooms in commercial applications plus bathrooms, showers, toilets, utilities and kitchens in domestic situations.

- **6 models**, with or without timer.
- Double motor-fan housing, antivibration supports and backdraught shutter for silent operation.
- Two speeds.
- Motor with ball bearings (guaranteed 30,000 hours of continuous operation) with thermal cut-out.
- Unobtrusive front grille.
- Support springs for the front grille, suitable for 65 mm max false ceilings.
- Metallic filter which can be removed and washed (dishwasher safe).
- “Intelligent” timer turns the unit on approximately 40 sec. after the activation. When switched off, the unit continues to operate at the minimum speed for between 30 sec. and 30 min. (depending on the setting).
- 100 mm dia. outlet spigot, all fans have the optional side or rear exit low profile connector, or high profile connector.
- Timer models, the timer is adjustable from 3 to 20 min.
- Data and performances IMQ Performance certified.
- Protection rating: IPX4.
- Insulation class: II □.

Spare Parts

- Metallic anti-dust filter.

TECHNICAL DATA

Models	Code		V-50Hz	W		A		RPM		Max Airflow				Max Pressure				Lp dB(A)*		Max °C	Kg
	basic	timer		min	max	min	max	min/max ⁽¹⁾	max/max ⁽²⁾	m ³ /h		l/s		mmH ₂ O		Pa		min	max		
										min	max	min	max	min	max	min	max				
VORT PRESS 110 LL I	11995	11996	220 - 240	12	24	0.07	0.18	970 1720	1090 1980	60 120	50 100	16.7 33.3	13.9 27.8	8.9 14.5	8.3 13.5	87 142	81 132	<30	41	2.1	
VORT PRESS 140 LL I	11971	11972		16	27	0.05	0.10	594 1130	450 829	55 118	67 140	15.3 32.8	18.6 38.9	8 22	8 22	78 216	78 216	<30	38	40	2.9
VORT PRESS 240 LL I	11973	11974		33	65	0.25	0.30	1250 2180	930 1550	120 220	130 240	33.3 61.1	36.1 66.7	32 33	32 34	314 324	314 334	44	56	3.3	

⁽¹⁾Rear air outlet. ⁽²⁾Side air outlet with high profile.



VORT PRESS I RANGE | TECHNICAL DATA FOR REGULATION N° 1254/2014/UE

	Models Code	Unit of measurement	VORT PRESS 110 LL I	VORT PRESS 140 LL I
			11995 - 11996	11971 - 11972
Supplier's name or trade mark		-	Vortice	Vortice
Specific Energy Consumption class SEC in average climate zone		-	NA	NA
Specific Energy Consumption class SEC average		kWh/m²a	-5,1	-5,8
Specific Energy Consumption class SEC cold			-18,5	-19,2
Specific Energy Consumption class SEC warm			2,5	1,8
Declared typology		-	RVU-U*	RVU-U*
Type of drive		-	NA	NA
Type of heat recovery system HRS		-	None	None
Thermal efficiency of heat recovery at reference air flow		%	NA	NA
Maximum flow rate		m³/s	117	133
Electric power input of the fan drive, including any motor control equipment, at maximum flow rate		W	23,1	23,5
Sound power level LWA		LWA [dB(A)]	62	59
Reference flow rate		m³/s	0,0228	0,0259
Reference pressure difference		Pa	66	88
SPI		W/(m³/h)	0,25641	0,23631
Control factor CTRL		%	1	1
Control typology		-	manual	manual
Maximum internal leakage rates		-	NA	NA
Maximum external leakage rates		%	NA	NA
Mixing rate		-	NA	NA
Position and description of visual filter warning		-	NA	NA
Airflow sensitivity to pressure variations at + 20 Pa and - 20 Pa		m³/h	NA	NA
Indoor/outdoor air tightness		-	NA	NA
Annual electricity consumption (AEC)		kWh electricity/a	353	326
AHS average Annual heating saved		kWh primary energy/a	1397	1397
AHS cold Annual heating saved			2732	2732
AHS warm Annual heating saved			632	632

* RVU-U: Unit Ventilation Residential - Unidirectional
 ** NRVU-U: Unit Ventilation Non Residential - Unidirectional
 *** MSD: Multi-Speed Drive

DIMENSIONS

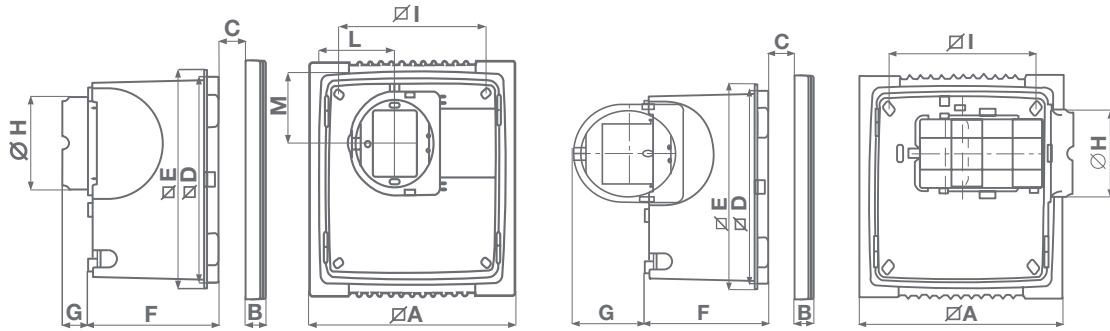

Models	∅ A	B	C	∅ D	∅ E	F	G	∅ H	∅ I	L	M
VORT PRESS 110 LL I	252	23	65	214.5	228	135.3	31.5/76.7	96.5	180	92	76

Dimensions (mm)

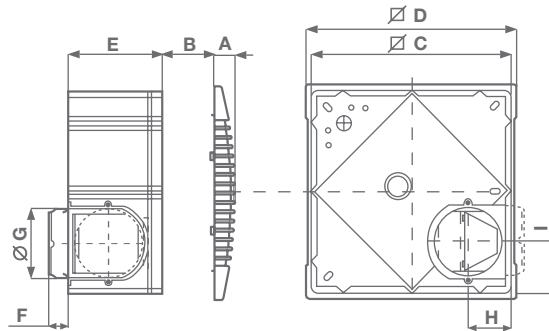

Models	A	∅ B	∅ C	D	E	F	∅ G	H	I
VORT PRESS 140 LL I	28	65	284	300	133	28.5	97	62	71.5
VORT PRESS 240 LL I									

Dimensions (mm)

MAIN COMPONENTS

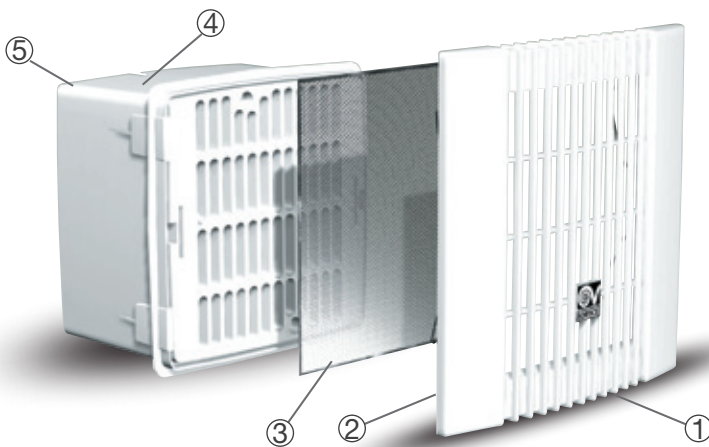

- ① Unobtrusive front grille with support springs which clamp it to the surface, making it suitable for all types of walls and ceilings (max 65 mm).
- ② Metallic filter can be removed and washed (dishwasher safe).
- ③ Made of rigid synthetic resin to guarantee high durability.
- ④ On 110 model, the outlet spigot can be changed to a high or low level spigot.
- ⑤ Silicon backdraught shutter on 140 and 240 models to avoid back flow when unit is turned off.

PERFORMANCE CURVES

VORT PRESS 110 LL I cod. 11995 - 11996

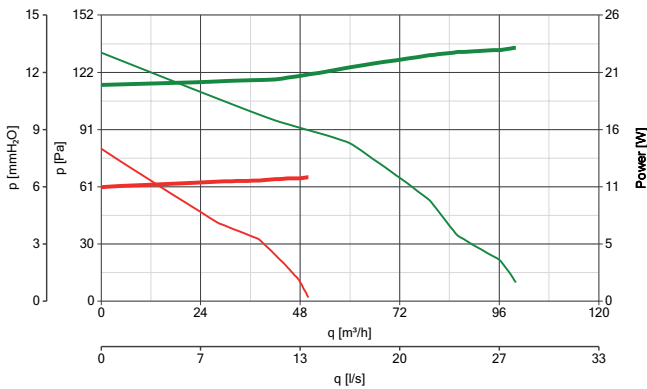

VORT PRESS 140 LL I cod. 11971 - 11972

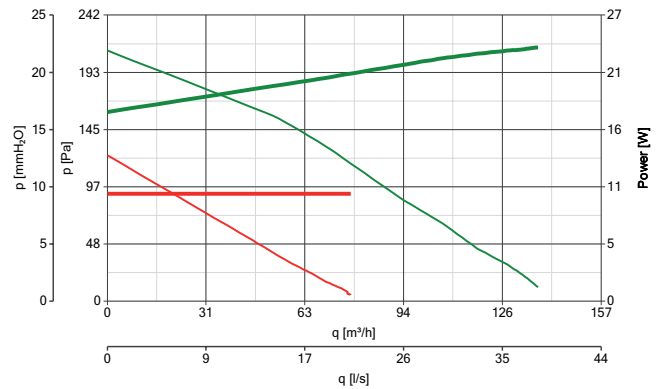

VORT PRESS 240 LL I cod. 11973 - 11974

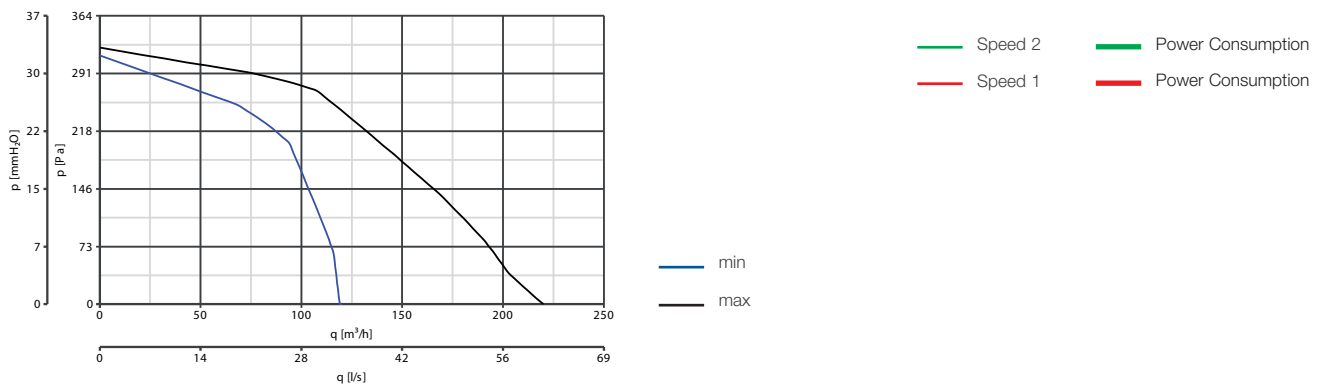

ACCESSORIES ON REQUEST

Models	Description	Code	Product	
	C 1.5 Electronic speed controller 1.5 A	12966	11995 - 11971 11973	
	SCNRB Electronic speed controller built-in	12971		
	SCB KIT Built-in controller adaptor for C 1.5	22481	12966	
	Air deflector	10/4	22310	All products
	High profile connector		22841	
	False-ceiling/wall installation kit		22823	22823
			22815	11971 - 11972 - 11973 - 11974
	Horizontal Outlet - Low Profile		22842	All Products
	Horizontal Outlet - High Profile		22823	All Products

Accessories on request (description and technical data on page 146)



Design: F. Trabucco & Associati



VORT PRESS HABITAT RANGE

Centrifugal duct fans **LONG LIFE 30.000 h**

PRODUCT SPECIFICATIONS

For continuous ventilation with boost facility. Ideal for use in public sector houses in bathrooms, showers, toilets, utility rooms and kitchens.

- **2 models:** basic and timer version.
- Motor with ball bearings (guaranteed 30,000 hours of continuous operation) with thermal cut-out.
- Two speeds.
- Double motor-fan housing, antivibration supports and backdraught shutter for silent operation.
- Metallic filter which can be removed and washed (dishwasher safe).
- 100 mm dia. outlet spigot.
- Fully comply with F1 Building Regulations, plus 1.9D alternative approaches.
- Data and performances IMQ Performance certified.
- Protection rating: IPX4.
- Insulation class: II □ .

Spare Parts

- Metallic anti-dust filter.

TECHNICAL DATA

Models	Code	V~50Hz	W min/max	A min/max	RPM min/max	Max Airflow		Max Pressure		Lp dB(A)* 3 m min/max	Max °C	Kg
						m³/h min/max	l/s min/max	mmH₂O min/max	Pa min/max			
VORT PRESS HABITAT LL 30/90	12002	230	8 22	0.06 0.18	820 1450	51 101	14.2 28.1	4 14	39 137	28.5 44.5	40	2.1
VORT PRESS HABITAT LL 45/135	12004		4 29	0.04 0.12	430 1170	52 149	14.4 41.4	5 23	49 225	26.5 48		

VORT PRESS HABITAT RANGE | TECHNICAL DATA FOR REGULATION N° 1254/2014/UE

	Models Code	Unit of measurement	VORT PRESS HABITAT LL 30/90	VORT PRESS HABITAT LL 45/135
			12002	12004
Supplier's name or trade mark	-	-	Vortice	Vortice
Specific Energy Consumption class SEC in average climate zone	-	-	NA	NA
Specific Energy Consumption class SEC average	kWh/m ² a	-	-2,6	-4,0
Specific Energy Consumption class SEC cold		-	-15,9	-17,3
Specific Energy Consumption class SEC warm		-	5,1	3,7
Declared typology	-	-	RVU-U*	RVU-U*
Type of drive	-	-	NA	NA
Type of heat recovery system HRS	-	-	None	None
Thermal efficiency of heat recovery at reference air flow	%	-	NA	NA
Maximum flow rate	m ³ /s	-	90	143
Electric power input of the fan drive, including any motor control equipment, at maximum flow rate	W	-	21,0	29,58
Sound power level LWA	LWA [dB(A)]	-	56	59
Reference flow rate	m ³ /s	-	0,0175	0,0278
Reference pressure difference	Pa	-	53	95
SPI	W/(m ³ /h)	-	0,33016	0,28971
Control factor CTRL	%	-	1	1
Control typology	-	-	manual	manual
Maximum internal leakage rates	-	-	NA	NA
Maximum external leakage rates	%	-	NA	NA
Mixing rate	-	-	NA	NA
Airflow sensitivity to pressure variations at + 20 Pa and - 20 Pa	m ³ /h	-	NA	NA
Indoor/outdoor air tightness	-	-	NA	NA
Annual electricity consumption (AEC)	kWh electricity/a	-	455	339
AHS average Annual heating saved	kWh primary energy/a	-	1397	1397
AHS cold Annual heating saved		-	2732	2732
AHS warm Annual heating saved		-	632	632
Position and description of visual filter warning	-	-	NA	NA

* RVU-U: Unit Ventilation Residential - Unidirectional
 ** NRVU-U: Unit Ventilation Non Residential - Unidirectional
 *** MSD: Multi-Speed Drive

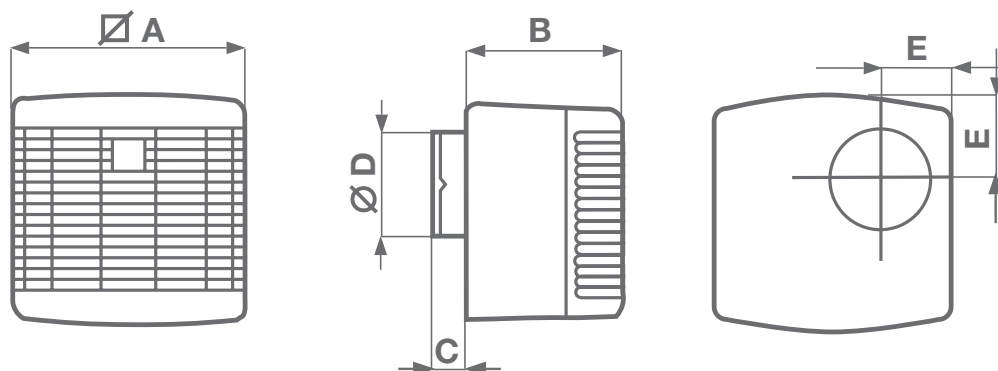
DIMENSIONS

Models	∅ A	B	C	∅ D	E
VORT PRESS HABITAT LL 30/90	202	147	30	97	73
VORT PRESS HABITAT LL 45/135	275	140	28		

Dimensions (mm)

MAIN COMPONENTS

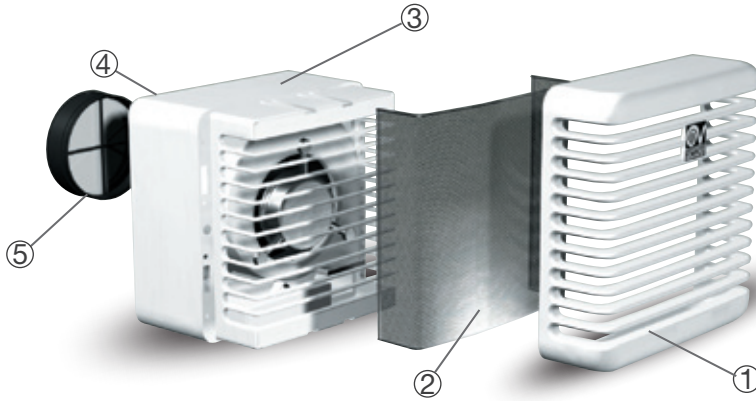

- ① Front grille.
- ② Metallic filter which can be removed and washed (dishwasher safe).
- ③ Made of rigid synthetic resin to guarantee high durability.
- ④ 100 mm dia. outlet spigot.
- ⑤ Silicon backdraught shutter to avoid back-flow when the unit is turned off.

PERFORMANCE CURVES

— Power consumption
— Performance curves

— Speed 1
— Speed 2

VORT PRESS HABITAT LL 30/90 cod. 12002

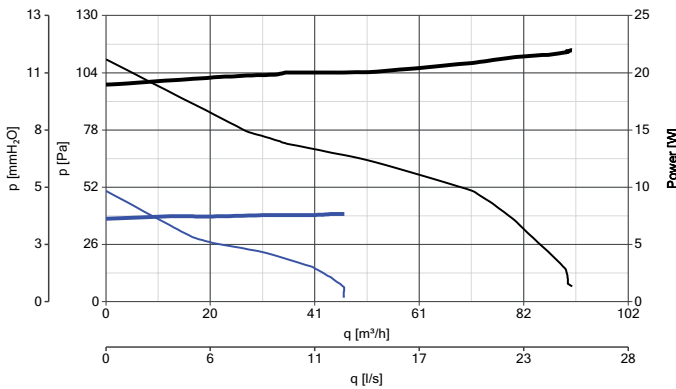

VORT PRESS HABITAT LL 45/135 cod. 12004

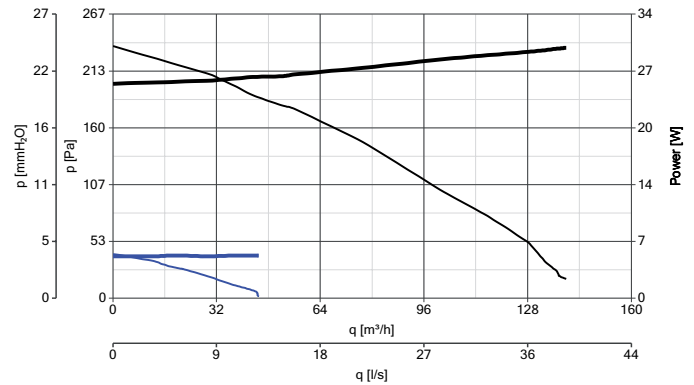

ACCESSORIES ON REQUEST

Models	Description	Code	Product	
	C 1.5 Electronic speed controller 1.5 A	12966	All products	
	SCNRB Electronic speed controller built-in	12971		
	SCB KIT Built-in controller adaptor for C 1.5	22481	12966	
	Air deflector	10/4	22310	All products

Accessories on request (description and technical data on page 146)

APPLICATIONS

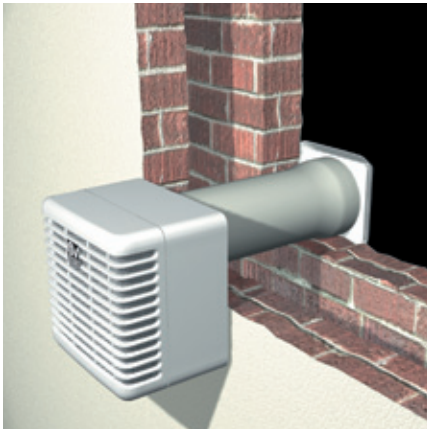



Design: F. Trabucco & Associates



VORT QUADRO RANGE

Centrifugal duct fans

PRODUCT SPECIFICATIONS

For the ventilation of medium-sized or large rooms in commercial premises plus bathrooms, showers, toilets, utilities and kitchens in domestic situations.

- **13 models:** 11 with or without timer and incorporated humidistat, 2 high-efficiency EC-DC brushless motor.
- Two Speeds. All models feature two speed operation, including timer equipped models.
- Motor with thermal cut-out incorporated.
- Backdraught shutter already installed on the product to avoid air back-flow when the unit is turned off.
- Vort Quadro fans guarantee a low environmental impact. Recyclable materials have been used and the "Design for Disassembly" technique has been followed.
- The units have a high extraction to long ducts are used. Reduced sound levels with superior certified performances on ducted applications.
- The energy saving can be really significant in case of continuous operation of the fan.
- It will also permit power savings associated with the recovery of heat.
- Timer models adjustable between 3 and 20 min.
- T-HCS model, adjustable RH threshold at 60%, 70%, 80%, 90% by mean of a slide switch during installation. The product automatically switches on when the indoor relative humidity level exceeds the pre-set value.
- Filter can be removed and washed.
- Easy to install and maintain.
- Data and performances IMQ Performance certified.
- Protection rating: IPX4.
- Insulation class: II .

RANGE

TIMER

T-HCS Humidity Control System - Timer

MICRO 80	11638 MICRO 80	11648 MICRO 80 T	
MICRO 100	11936 MICRO 100	11940 MICRO 100 T	11945 MICRO 100 THCS
MICRO 100 ES	11937 MICRO 100 ES	1941 MICRO 100 T ES	
MEDIO	11944 MEDIO	11946 MEDIO T	11975 MEDIO THCS
SUPER	11952 SUPER	11954 SUPER T	11989 SUPER THCS



TECHNICAL DATA

Models	V~50Hz	W min/max	A min/max	RPM min/max	Max Airflow		Max Pressure		Lp dB(A)* 3 m min/max	Max °C	Kg
					m³/h min/max	l/s min/max	mmH ₂ O min/max	Pa min/max			
MICRO 80	220 - 240	19 27	0.10 0.13	1150 1580	60 85	17 24	22 27	216 265	28.7 37.0	50	1.79
MICRO 100		20 28		1180 1600	65 90	18 25	16 22	157 216	32.3 39.2		
MICRO 100 ES		8 15	0.08 0.12	1235 1630			9 18	88 177	31.5 37.4		
MEDIO		42 53	0.20 0.26	1380 1800	125 170	35 47	34 37	334 363	36.7 43.4	40	2.54
SUPER		65 95	0.30 0.48	1400 2040	185 270	51 75	42 50	412 491	41.9 48.6	50	3.77

VORT QUADRO RANGE | TECHNICAL DATA FOR REGULATION N° 1254/2014/UE

	Models	Unit of measurement	MICRO 80	MICRO 100
	Code		11638 - 11648	11936 - 11940 - 11945
Supplier's name or trade mark	-	-	Vortice	Vortice
Specific Energy Consumption class SEC in average climate zone	-	-	NA	NA
Specific Energy Consumption class SEC average	kWh/m²a	-	-2,6	0,0
Specific Energy Consumption class SEC cold		-	-15,9	-13,3
Specific Energy Consumption class SEC warm		-	5,1	7,7
Declared typology	-	-	RVU-U*	RVU-U*
Type of drive	-	-	NA	NA
Type of heat recovery system HRS	-	-	None	None
Thermal efficiency of heat recovery at reference air flow	%	%	NA	NA
Maximum flow rate	m³/s	m³/s	90	92
Electric power input of the fan drive, including any motor control equipment, at maximum flow rate	W	W	21,0	28,1
Sound power level LWA	LWA [dB(A)]	LWA [dB(A)]	56	60
Reference flow rate	m³/s	m³/s	0,0175	0,0179
Reference pressure difference	Pa	Pa	53	96
SPI	W/(m³/h)	W/(m³/h)	0,33016	0,40683
Control factor CTRL	%	%	1	1
Control typology	-	-	manual	manual
Maximum internal leakage rates	-	-	NA	NA
Maximum external leakage rates	%	%	NA	NA
Mixing rate	-	-	NA	NA
Position and description of visual filter warning	-	-	NA	NA
Airflow sensitivity to pressure variations at + 20 Pa and - 20 Pa	m³/h	m³/h	NA	NA
Indoor/outdoor air tightness	-	-	NA	NA
Annual electricity consumption (AEC)	kWh electricity/a	kWh electricity/a	455	561
AHS average Annual heating saved	kWh primary energy/a	kWh primary energy/a	1397	1397
AHS cold Annual heating saved			2732	2732
AHS warm Annual heating saved			632	632

* RVU-U: Unit Ventilation Residential - Unidirectional
 ** NRUVU-U: Unit Ventilation Non Residential - Unidirectional
 *** MSD: Multi-Speed Drive



RESIDENTIAL VENTILATION

DIMENSIONS

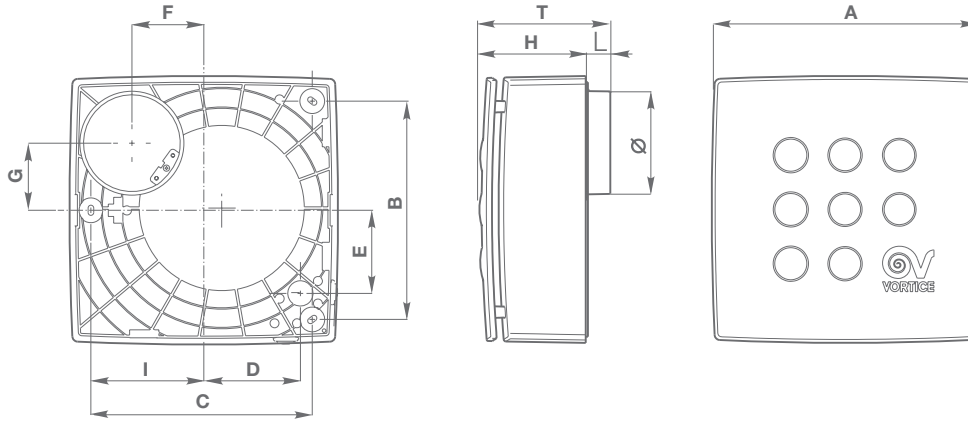

Models	A	B	C	D	E	F	G	H	I	L	T	Ø
MICRO 80	239	195	197	85	74	64	60	97	100	20	117	73.5
MICRO 100												92.5/97
MICRO 100 ES												
MEDIO	261	212	215	95	82	75	69	119	110		138	
SUPER	290	236	239	108	92	87	81	144	125		164	

Dimensions (mm)

PERFORMANCE CURVES

PERFORMANCE CURVES
 — max
 — min
 POWER CONSUMPTION
 — max
 — min

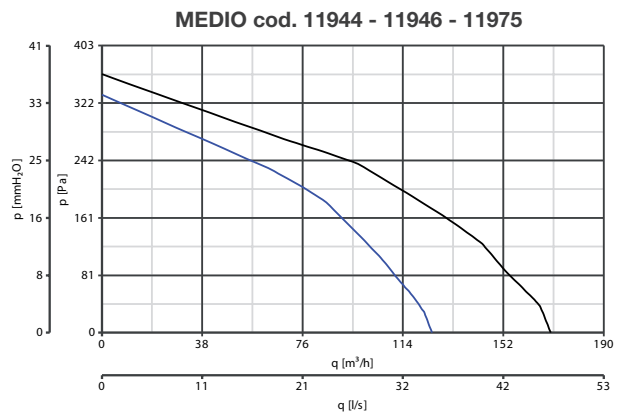
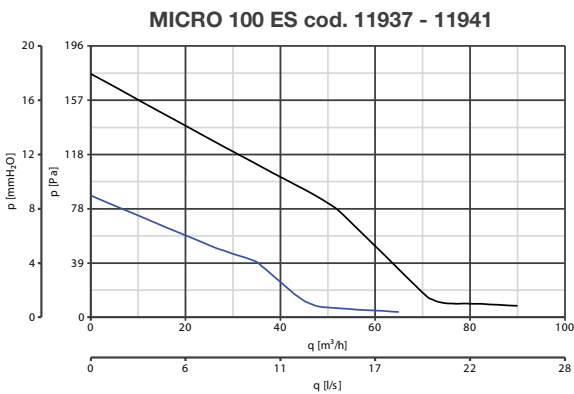
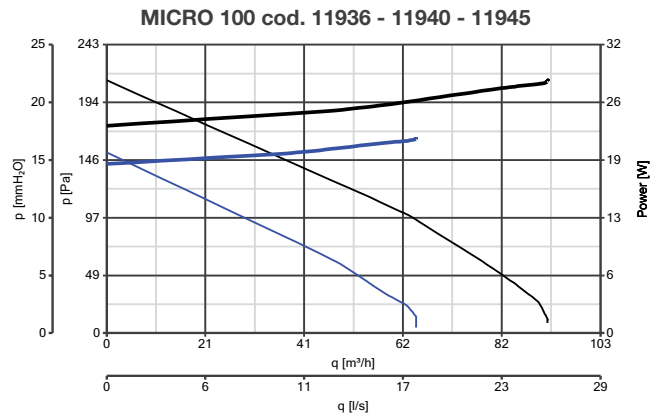
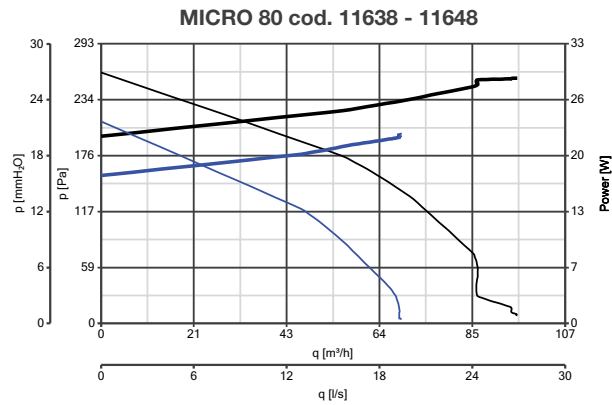

PERFORMANCE CURVES

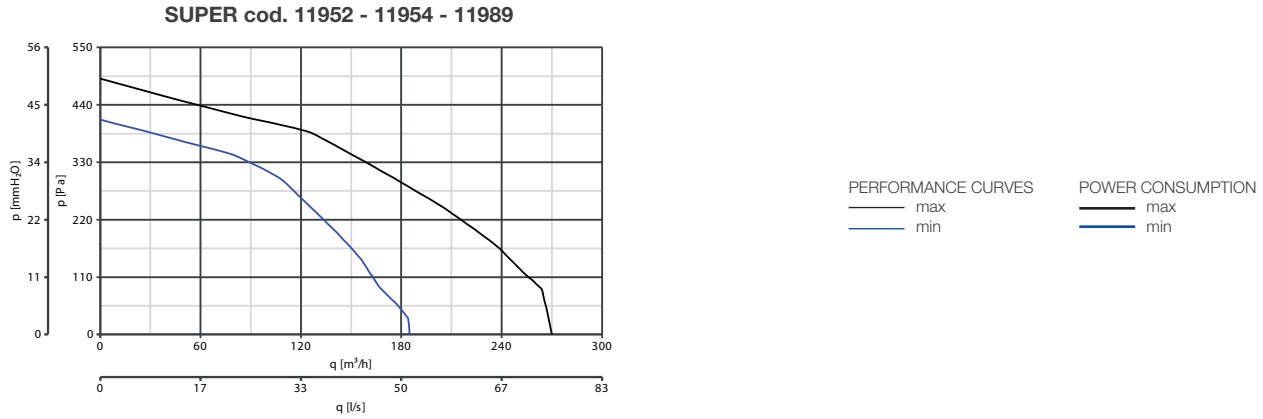

ACCESSORIES ON REQUEST

Models	Description	Code	Product	
	C 1.5 Electronic speed controller 1.5 A	12966	11638 - 11936 - 11937 - 11944 - 11952	
	SCNRB Electronic speed controller built-in	12971		
	SCB KIT Bult-in controller adaptor for C 1.5	22481	12966	
	Air deflector	10/4	22310	All products

APPLICATIONS

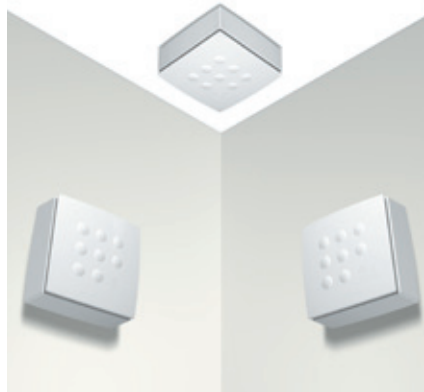



Design: F. Trabucco & Ass.



VORT QUADRO I RANGE

Centrifugal duct fans for flush mounting

PRODUCT SPECIFICATIONS

For the ventilation of medium-sized or large rooms in commercial premises plus bathrooms, showers, toilets, utilities and kitchens in domestic situations.

- **11 models:** 9 with or without timer and incorporated humidistat, 2 high-efficiency EC-DC brushless motor.
- Flush mounting.
- Two Speeds. All models feature two speed operation, including timer equipped models.
- Motor with thermal cut-out incorporated.
- Backdraught shutter already installed on the product to avoid air back-flow when the unit is turned off.
- The units have a high extraction to long ducts are used. Reduced sound levels with superior certified performances on ducted applications.
- The energy saving can be really significant in case of continuous operation of the fan.
- It will also permit power savings associated with the recovery of heat.
- Timer models adjustable between 3 and 20 min.
- T-HCS model, adjustable RH threshold at 60%, 70%, 80%, 90% by mean of a slide switch during installation. The product automatically switches on when the indoor relative humidity level exceeds the pre-set value
- Filter can be removed and washed.
- Easy to install and mantain.
- Data and performances IMQ Performance certified.
- Protection rating: IPX4.
- Insulation class: II □.

RANGE

TIMER

T-HCS Humidity Control System - Timer

MICRO 100 I	12017 MICRO 100 I	12018 MICRO 100 I T	12065 MICRO 100 I THCS
MICRO 100 I ES	12045 MICRO 100 I ES	12046 MICRO 100 I T ES	
MEDIO I	12020 MEDIO I	12021 MEDIO I T	12066 MEDIO I THCS
SUPER I	12023 SUPER I	12024SUPER I T	12067 SUPER I THCS

TECHNICAL DATA

Models	V~50Hz	W min/max	A min/max	RPM min/max	Max Airflow		Max Pressure		Lp dB(A)* 3 m		Max °C	Kg
					m ³ /h min/max	l/s min/max	mmH ₂ O min/max	Pa min/max	frontal	side		
MICRO 100 I	220 - 240	20 27	0.10 0.12	1010 1450	75 110	21 31	20 25	196 245	26.3 34.3	25.9 33.5	50	1.91
MICRO 100 I ES		8 15	0.08 0.12	1090 1430	75 100	21 28	9 18	88 177	31.8 38.4	29.9 37.8		
MEDIO I		45 60	0.21 0.27	1200 1600	130 180	36 50	34 37	334 363	35.9 41.2	33.4 39.6	50	4.27
SUPER I		70 100	0.31 0.48	1300 1900	190 280	53 78	42 50	412 491	33.6 46.7	30 44.6		

VORT QUADRO I RANGE | TECHNICAL DATA FOR REGULATION N° 1254/2014/UE

Models Code	Unit of measurement	MICRO 100 I
		12017 - 12018 - 12065
Supplier's name or trade mark	-	Vortice
Specific Energy Consumption class SEC in average climate zone	-	NA
Specific Energy Consumption class SEC average	kWh/m ² a	-1,7
Specific Energy Consumption class SEC cold		-15,0
Specific Energy Consumption class SEC warm		6,0
Declared typology	-	RVU-U*
Type of drive	-	NA
Type of heat recovery system HRS	-	None
Thermal efficiency of heat recovery at reference air flow	%	NA
Maximum flow rate	m ³ /s	100
Electric power input of the fan drive, including any motor control equipment, at maximum flow rate	W	27,0
Sound power level LWA	LWA [dB(A)]	54
Reference flow rate	m ³ /s	0,0194
Reference pressure difference	Pa	95
SPI	W/(m ³ /h)	0,35714
Control factor CTRL	%	1
Control typology	-	manual
Maximum internal leakage rates	-	NA
Maximum external leakage rates	%	NA
Mixing rate	-	NA
Airflow sensitivity to pressure variations at + 20 Pa and - 20 Pa	m ³ /h	NA
Indoor/outdoor air tightness	-	NA
Annual electricity consumption (AEC)	kWh electricity/a	492
AHS average Annual heating saved	kWh primary energy/a	1397
AHS cold Annual heating saved		2732
AHS warm Annual heating saved		632
Position and description of visual filter warning	-	NA

* RVU-U: Unit Ventilation Residential - Unidirectional
 ** NRVU-U: Unit Ventilation Non Residential - Unidirectional
 *** MSD: Multi-Speed Drive



RESIDENTIAL VENTILATION

DIMENSIONS

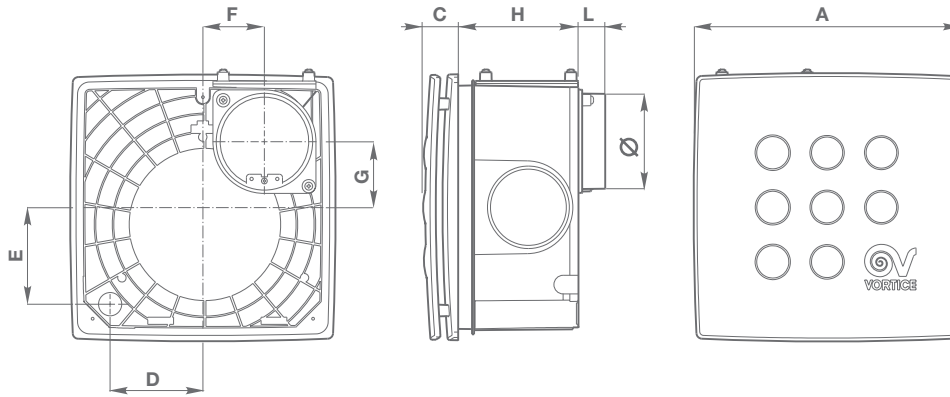

Models	A	C	D	E	F	G	H	L	I	Ø
MICRO 100 I	258	34	92	90	64	60	118	26	92.5/97	92.5/97
MICRO 100 I ES										
MEDIO I	287	37	97	103	72	69	130			
SUPER I	314	38	120	120	80	81	153			

Dimensions (mm)

PERFORMANCE CURVES

POWER CONSUMPTION



— max
— min

PERFORMANCE CURVES

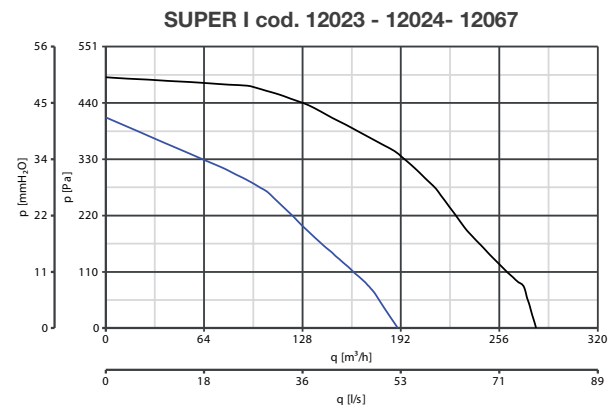
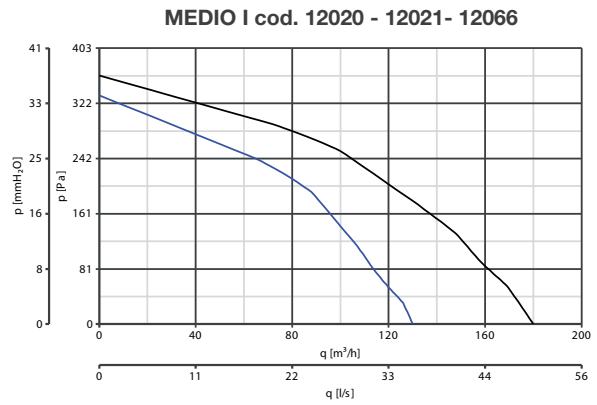
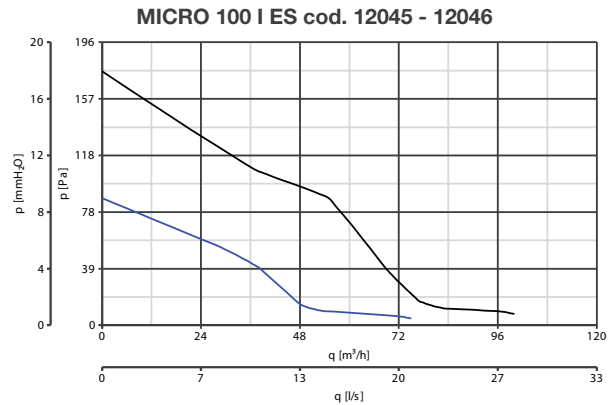
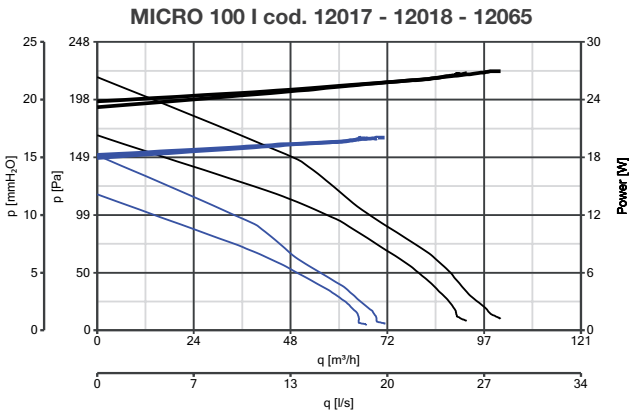
— max
— min



ACCESSORIES ON REQUEST

Models	Description	Code	Product	
	C 1.5 Electronic speed controller 1.5 A	12966	12017 - 12045 - 12020 - 12023	
	SCNRB Electronic speed controller built-in	12971		
	Air deflector	10/4	All products	
	Ceiling Kit	MICRO	22491	12017 - 12018 - 12065 - 12045 - 12046
		MEDIO	22492	12020 - 12021 - 12066
		SUPER	22493	12023 - 12024 - 12067

Accessories on request (description and technical data on page 146)

APPLICATIONS





VORT NOTUS RANGE

De-centralised continuous axial fans

PRODUCT SPECIFICATIONS

Wide range of possible installations: through wall and ceiling.

- **2 models:** VORT NOTUS, VORT NOTUS T-HCS.
- Motor housing made of self-extinguishing (V0) polypropylene.
- Electrically controlled EC brushless motors offer optimal performance and extremely low energy consumption.
- Ball bearing motor.
- Flange, grille and front panel made of ABS.
- 3 levels of performance.
- Designed for continuous running.
- Very quiet running.
- In duct installation (Vort Notus only).
- Protection rating: IPX4.
- Insulation class: II □ .

VORT NOTUS T-HCS:

- The R.H. sensor allows the automatic switch from minimum to maximum airflow when relative humidity exceeds the threshold setting (levels available: 60%, 70%, 80%, 90%).
- Timer function (activated by external switch) can be overrided the humidity detection system and run the product on boost speed.
- Timer adjustable between 3 and 20 minutes.

TECHNICAL DATA

Models	Code	V~50Hz	W min/max	A min/max	Max Airflow		Max Pressure		Lp dB(A)* 3 m min/max	Max °C	Kg
					m³/h min/max	l/s min/max	mmH ₂ O min/max	Pa min/max			
VORT NOTUS	11903	220 - 230	1.5 2.8	0,018 0,025	11.7 42.0	3.3 11.7	2.4 8.8	23.5 86.3	27.5 28.5	50	0.80
VORT NOTUS T-HCS	11177		2.1 6.4	2.1 6.4						60	

VORT NOTUS RANGE | TECHNICAL DATA FOR REGULATION N° 1254/2014/UE

	Models Code	Unit of measurement	VORT NOTUS - VORT NOTUS T-HCS
			11903 - 11177
Supplier's name or trade mark	-	-	Vortice
Specific Energy Consumption class SEC in average climate zone	-	-	NA
Specific Energy Consumption class SEC average	kWh/m ² a	-	-6,2
Specific Energy Consumption class SEC cold		-	-19,5
Specific Energy Consumption class SEC warm		-	1,5
Declared typology	-	-	RVU-U*
Type of drive	-	-	NA
Type of heat recovery system HRS	-	-	None
Thermal efficiency of heat recovery at reference air flow	-	%	NA
Maximum flow rate	-	m ³ /s	43
Electric power input of the fan drive, including any motor control equipment, at maximum flow rate	-	W	3,5
Sound power level LWA	-	LWA [dB(A)]	32,4
Reference flow rate	-	m ³ /s	0,0084
Reference pressure difference	-	Pa	62
SPI	-	W/(m ³ /h)	0,222591
Control factor CTRL	-	%	1
Control typology	-	-	manual
Maximum internal leakage rates	-	-	NA
Maximum external leakage rates	-	%	NA
Mixing rate	-	-	NA
Position and description of visual filter warning	-	-	NA
Airflow sensitivity to pressure variations at + 20 Pa and - 20 Pa	-	m ³ /h	NA
Indoor/outdoor air tightness	-	-	NA
Annual electricity consumption (AEC)	-	kWh electricity/a	311
AHS average Annual heating saved	-	kWh primary energy/a	1397
AHS cold Annual heating saved	-		2732
AHS warm Annual heating saved	-		632

* RVU-U: Unit Ventilation Residential - Unidirectional
 ** NRVU-U: Unit Ventilation Non Residential - Unidirectional
 *** MSD: Multi-Speed Drive

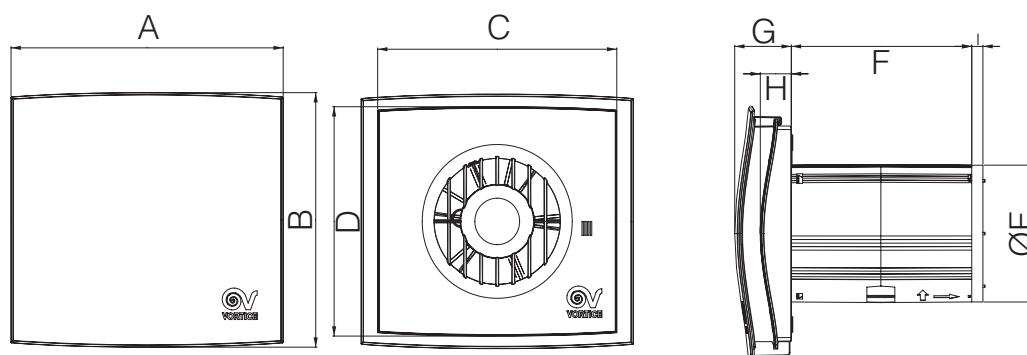
DIMENSIONS

Models	A	B	C	D	Ø E	F	G	H	I
VORT NOTUS	194.6	182	171	164	97.8	129	40.5	22.2	8
VORT NOTUS T-HCS									

Dimensions (mm)

PERFORMANCE CURVES

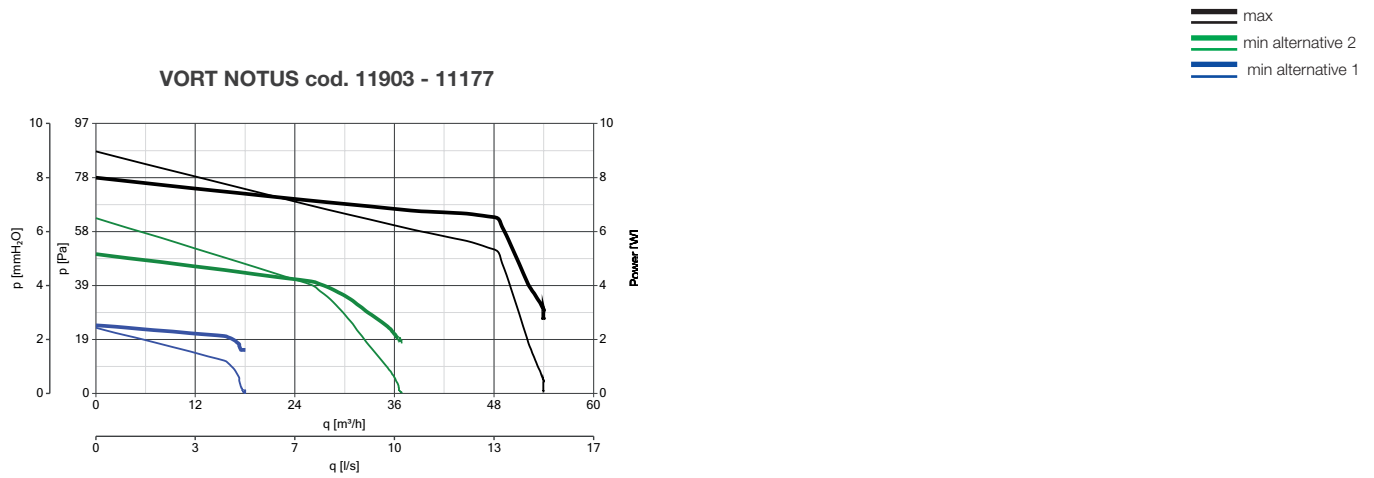

APPLICATIONS

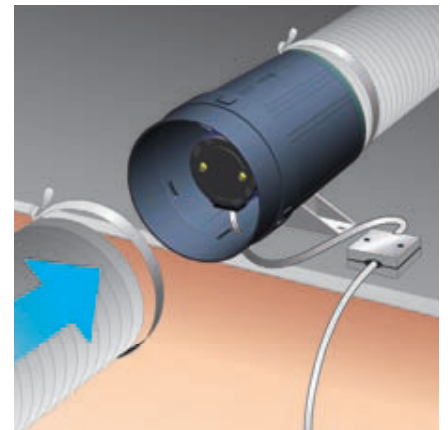
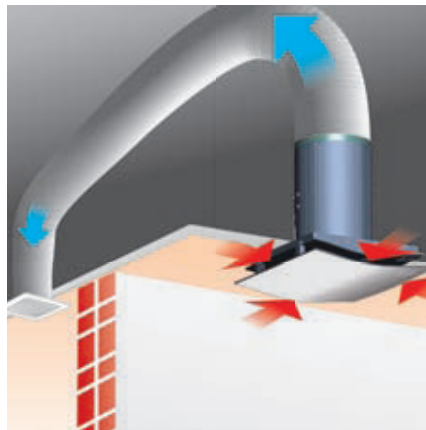
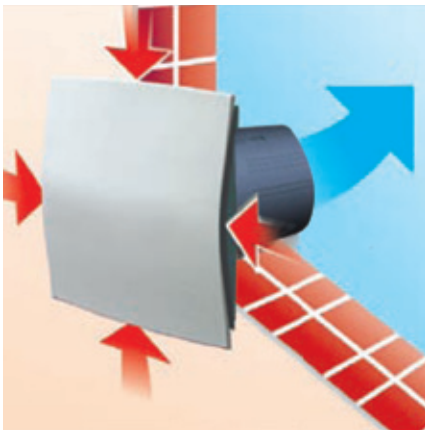



NOTE



VORT PLATT RANGE

Centralised continuous ventilation units



PRODUCT SPECIFICATIONS

Suitable for horizontal and vertical installations on walls, ceilings and false ceiling.

- **2 models:** VORT PLATT, VORT PLATT ES.
- Designed to guarantee efficient ventilation of the home in continuous operating mode.
- Long lasting galvanized steel cover.
- Rear flange made of ABS.
- Ball bearing motor.
- Two speeds.
- Inlets: 3 x 80 mm + 1 x 125 mm diameter.
- Outlet: 1 x 125 mm diameter.
- Protection rating: IPX4.
- Insulation class: II .

VORT PLATT

- AC motor external rotor with thermally protected.
- VORT PLATT supplied with 2 spigots (30 m³/h) and 1 blank.

VORT PLATT ES:

- Electrically controlled EC brushless motors offer optimal performance and extremely low energy consumption.
- 3 alternative settings selectable by dip switch.
- Very high efficiency: specific fan power down to 0.2 [W/l/s].
- Timer 30'.
- VORT PLATT ES supplied with 2 spigots and 1 blank.



TECHNICAL DATA

Models	Code	V~50Hz	W min/max	A min/max	RPM min/max	Max Airflow		Max Pressure		Lp dB(A)* 3 m min/max	Max °C	Kg
						m ³ /h min/max	l/s min/max	mmH ₂ O min/max	Pa min/max			
VORT PLATT	11814	230	20 55	0.18 0.24	1280 2540	200 400	56 111	20 41	206 402	27.2* -	60	4
VORT PLATT ES	11813		12 50	0.12 0.45	830 1400	215 365	60 101	5 14.5	49 142	26.5** 36	50	4

*Vort Platt Lp dB(A) measured at kitchen port at minimum speed.

** Vort Platt ES: Lp dB(A) 3 m measured in configuration 3+1.



VORT PLATT RANGE | TECHNICAL DATA FOR REGULATION N° 1254/2014/UE

	Models Code	Unit of measurement	VORT PLATT ES
			11813
Supplier's name or trade mark		-	Vortice
Specific Energy Consumption class SEC in average climate zone		-	E
Specific Energy Consumption class SEC average			-13.4
Specific Energy Consumption class SEC cold		kWh/m²a	-23.2
Specific Energy Consumption class SEC warm			-2.2
Declared typology		-	RVU-U*
Type of drive		-	MSD***
Type of heat recovery system HRS		-	None
Thermal efficiency of heat recovery at reference air flow		%	NA
Maximum flow rate		m³/s	0,0661
Electric power input of the fan drive, including any motor control equipment, at maximum flow rate		W	32
Sound power level LWA		LWA [dB(A)]	43
Reference flow rate		m³/s	0,0463
Reference pressure difference		Pa	95
SPI		W/(m³/h)	0,12005
Control factor CTRL		%	1
Control typology		-	manual
Maximum internal leakage rates		-	NA
Maximum external leakage rates		%	NA
Mixing rate		-	NA
Position and description of visual filter warning		-	NA
Airflow sensitivity to pressure variations at + 20 Pa and - 20 Pa		m³/h	NA
Indoor/outdoor air tightness		-	NA
Annual electricity consumption (AEC)		kWh electricity/a	150
AHS average Annual heating saved		kWh primary energy/a	1715
AHS cold Annual heating saved			2732
AHS warm Annual heating saved			632

* RVU-U: Unit Ventilation Residential - Unidirectional
 ** NRUV-U: Unit Ventilation Non Residential - Unidirectional
 *** MSD: Multi-Speed Drive



RESIDENTIAL VENTILATION

DIMENSIONS

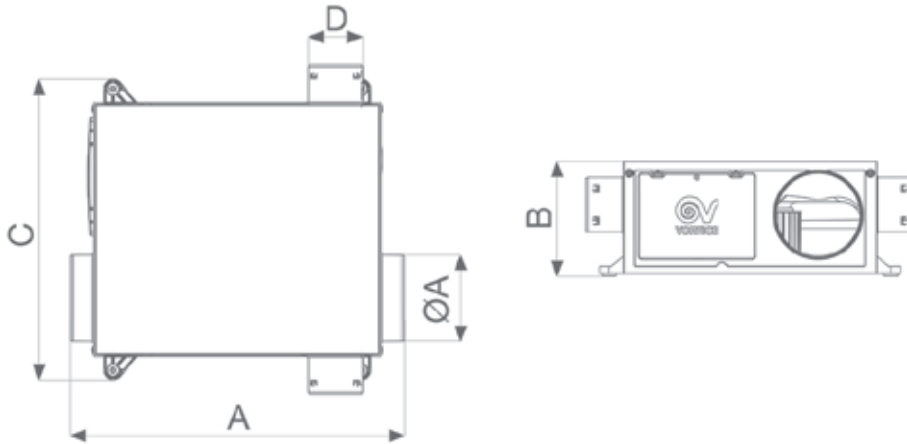

Models	Ø A	A	B	C	D
VORT PLATT	124,5	478	164	430	77,5
VORT PLATT ES					

Dimensions (mm)

PERFORMANCE CURVES

POWER CONSUMPTION:
 Max
 Min

PERFORMANCE CURVES:
 Max
 Min

min (1+1) max (1+1)
 min (2+1) max (2+1)
 min (3+1) max (3+1)

VORT PLATT - cod. 11814

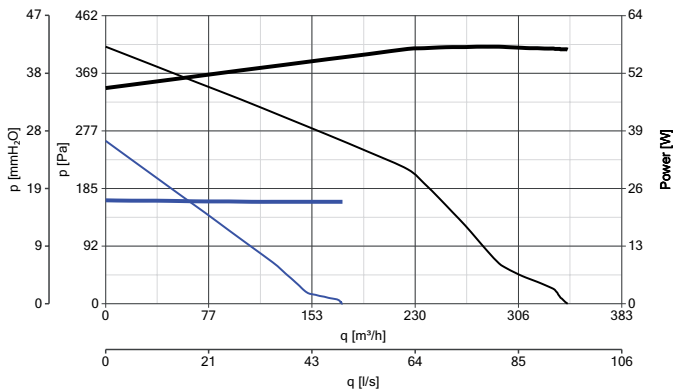

VORT PLATT ES - cod. 11813

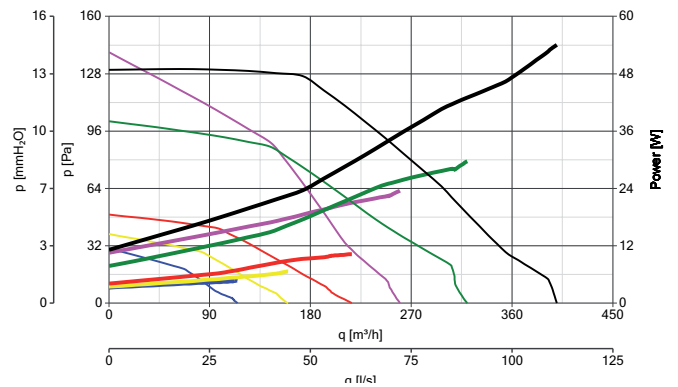

ACCESSORIES ON REQUEST

Models	Description	Code	Product
	Regulator	15³/h	22324
		30³/h	22325
	Additional spigot - Hygro 80	22847	All products

Accessories on request (description and technical data on page 146)

APPLICATIONS

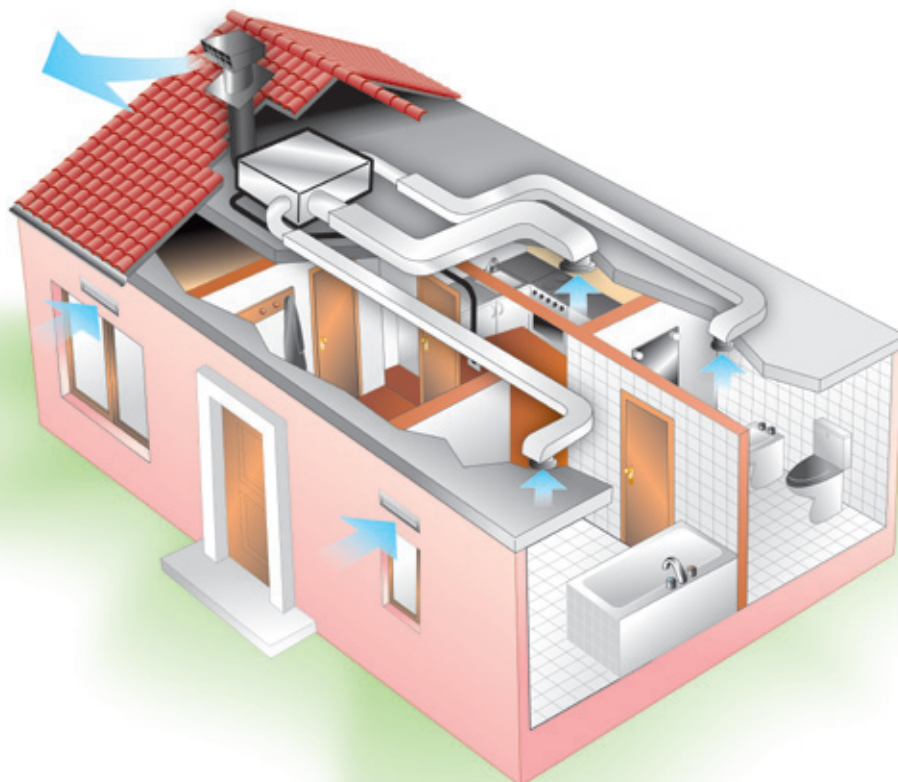
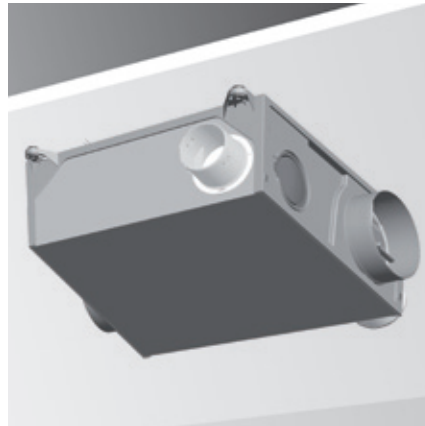
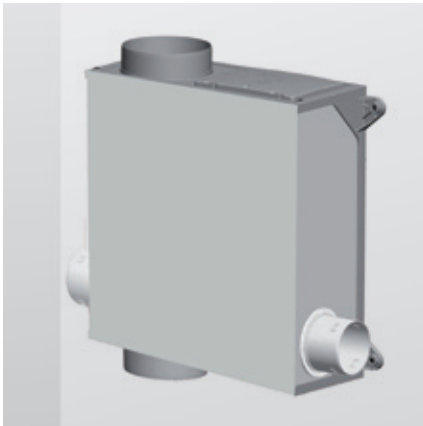



VORT PENTA RANGE

Centralised continuous ventilation units

PRODUCT SPECIFICATIONS

Designed to guarantee efficient ventilation of the home in continuous operating mode. Extraction up to 6 rooms.

- **2 models:** VORT PENTA, VORT PENTA ES.
- ABS made.
- Ball bearing motor.
- Two speeds.
- Inlets: 5 x 80 mm + 1 x 125 mm diameter.
- Outlet: 1 x 125 mm diameter.
- New time-saving automatic kitchen flow regulation.
- Internal ducting designed to guarantee high performance, low consumption and reduced noise levels.
- Designed for installation in false ceilings, these are set up for suspended mounting by means of a cord supplied as standard.
- Alternatively, the integrated rotating bracket is available; this makes the fan very easy to install in any position, as it ensures the setup is suited to system requirements.
- Protection rating: IPX4.
- Insulation class: II □.

Vort Penta

- AC motor.
- Supplied with 2 spigots (30 m³) and 4 blanks.

Vort Penta ES

- Electrically controlled EC brushless motors offer optimal performance and extremely low energy consumption.
- 5 alternative settings selectable by dip switch.
- Very high efficiency: specific fan power down to 0.2 [W/l/s].
- Timer 30'.
- Supplied with 3 spigots and 3 blanks.



TECHNICAL DATA

Models	Code	V~50Hz	W min/max	A min/max	RPM min/max	Max Airflow		Max Pressure		Lp dB(A)* 3 m min/max	Max °C	Kg
						m ³ /h min/max	l/s min/max	mmH ₂ O min/max	Pa min/max			
VORT PENTA	11707	230	21 73	0.18 0.34	1245 2160	206 340	59,9 94,4	24.4 43,0	240,1 421,9	- 31,9	40	4,4
VORT PENTA ES	11767		13 35	0.13 0.31	1350 2000	250 375	69,5 104	11.5 26	113 255	35 43	50	4



VORT PENTA RANGE | TECHNICAL DATA FOR REGULATION N° 1254/2014/UE

	Models Code	Unit of measurement	VORT PENTA	VORT PENTA ES
			11707	11813
Supplier's name or trade mark	-	-	Vortice	Vortice
Specific Energy Consumption class SEC in average climate zone	-	-	E	E
Specific Energy Consumption class SEC average	kWh/m ² a		-11,1	-14,9
Specific Energy Consumption class SEC cold			-20,7	-24,9
Specific Energy Consumption class SEC warm			0,4	-3,9
Declared typology	-	-	RVU-U*	RVU-U*
Type of drive	-	-	MSD***	MSD***
Type of heat recovery system HRS	-	-	None	None
Thermal efficiency of heat recovery at reference air flow	%		NA	NA
Maximum flow rate	m ³ /s		268	280
Electric power input of the fan drive, including any motor control equipment, at maximum flow rate	W		80	32,8
Sound power level LWA	LWA [dB(A)]		50	47
Reference flow rate	m ³ /s		0,0521	0,0544
Reference pressure difference	Pa		90	50
SPI	W/(m ³ /h)		0,1935	0,07143
Control factor CTRL	%		1	1
Control typology	-		manual	manual
Maximum internal leakage rates	-		NA	NA
Maximum external leakage rates	%		9,6	9,6
Mixing rate	-		NA	NA
Position and description of visual filter warning	-		NA	NA
Airflow sensitivity to pressure variations at + 20 Pa and - 20 Pa	m ³ /h		NA	NA
Indoor/outdoor air tightness	-		NA	NA
Annual electricity consumption (AEC)	kWh electricity/a		242	89
AHS average Annual heating saved	kWh primary energy/a		1715	1715
AHS cold Annual heating saved		3732	2732	
AHS warm Annual heating saved		632	632	

* RVU-U: Unit Ventilation Residential - Unidirectional
 ** NRUVU-U: Unit Ventilation Non Residential - Unidirectional
 *** MSD: Multi-Speed Drive



RESIDENTIAL VENTILATION

DIMENSIONS

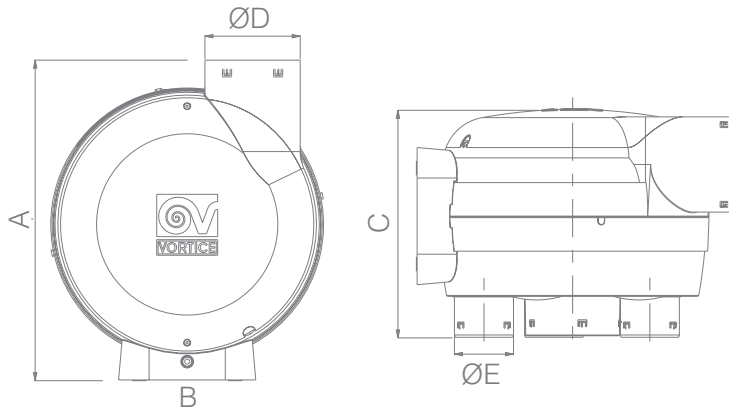

Models	A	B	C	Ø D	Ø E
VORT PENTA	420	358	300	125	77.5
VORT PENTA ES					

Dimensions (mm)

PERFORMANCE CURVES

POWER CONSUMPTION
 — max
 — med
 — min

PERFORMANCE CURVES
 — max
 — med
 — min

— min (1+1) — max (1+1)
 — min (2+1) — max (2+1)
 — min (3+1) — max (3+1)



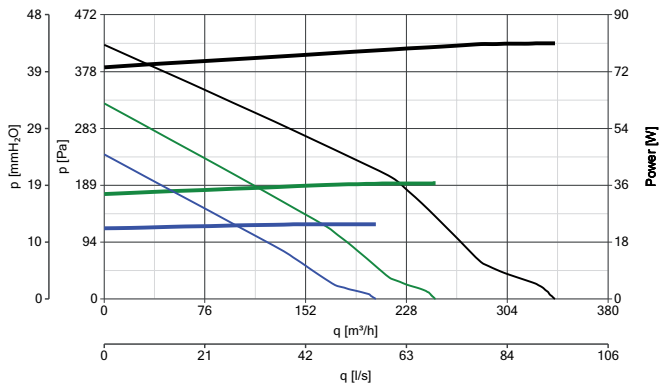

VORT PENTA - cod. 11707

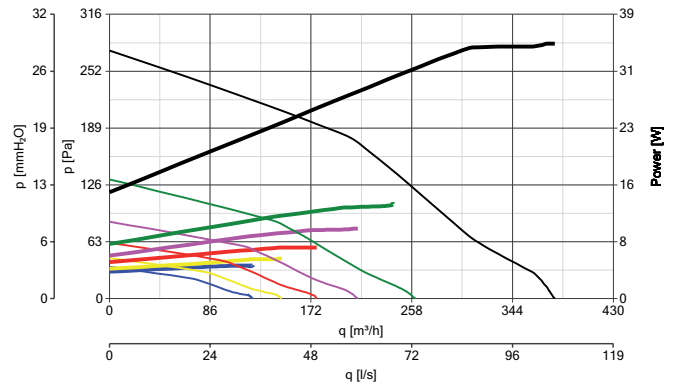

VORT PENTA ES - cod. 11767



ACCESSORIES ON REQUEST

Models	Description	Code	Product
	Regulator	15 ³ /h	All products
		30 ³ /h	
	Additional spigot - Hygro 80	22847	All products
	Intake Grille	Ø 80	All products
		Ø 125	
	Automatic air inlet	15 m ³ /h	All products
		30 m ³ /h	
	Automatic acoustic Inlet	22 m ³ /h	All products
		30 m ³ /h	
		45 m ³ /h	

Accessories on request (description and technical data on page 146)

APPLICATIONS

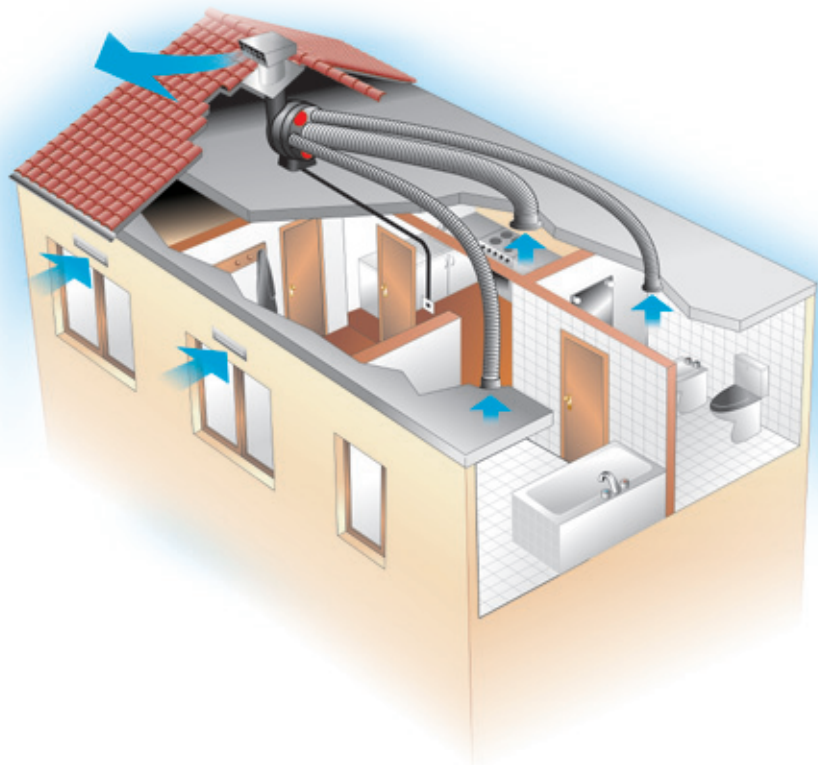



VORT LETO MEV RANGE

Centralised continuous ventilation units

PRODUCT SPECIFICATIONS

Designed for continuous operation in domestic or commercial environments. Extraction up to 500 m³/h.

- **2 models:** VORT LETO MEV, VORT LETO MEV RF equipped with RF remote controller.
- ABS made.
- Electrically controlled EC brushless motors offer optimal performance and extremely low energy consumption.
- Ball bearing motor.
- Two speeds.
- Very high efficiency: specific fan power down to 0.2 [W/l/s].
- Inlets: 4x125 mm diameter.
- Outlet: 1x125 mm diameter.
- Supplied with 2 blanks.
- Precise speed setting with potentiometers in order to achieve maximum energy saving.
- Easy vertical or horizontal wall or ceiling installation.
- Protection rating: IPX4.
- Insulation class: II .

VORT MEV RF

- RF remote controller, powered by long lasting solar cells, allows speed selection and timer activation. Timer.



TECHNICAL DATA

Models	Code	V~50Hz	W min/max	A min/max	RPM min/max	Max Airflow		Max Pressure		Lp dB(A)* 3 m min/max	Max °C	Kg
						m ³ /h min/max	l/s min/max	mmH ₂ O min/max	Pa min/max			
VORT LETO MEV	11955	230	3.2 70	0.4 0.55	400 2150	72	20	10	98.1	51.5	50	3
VORT LETO MEV RF	11953					500	138.9	41.8	410			



VORT LETO MEV RANGE | TECHNICAL DATA FOR REGULATION N° 1254/2014/UE

	Models Code	Unit of measurement	VORT LETO MEV - VORT LETO MEV RF
			11955 - 11953
Supplier's name or trade mark		-	Vortice
Specific Energy Consumption class SEC in average climate zone		-	E
Specific Energy Consumption class SEC average		kWh/m ² a	-13,5
Specific Energy Consumption class SEC cold			-23,3
Specific Energy Consumption class SEC warm			-2,2
Declared typology		-	RVU-U*
Type of drive		-	MSD***
Type of heat recovery system HRS		-	None
Thermal efficiency of heat recovery at reference air flow		%	NA
Maximum flow rate		m ³ /s	411
Electric power input of the fan drive, including any motor control equipment, at maximum flow rate		W	63,0
Sound power level LWA		LWA [dB(A)]	63
Reference flow rate		m ³ /s	0,0799
Reference pressure difference		Pa	98
SPI		W/(m ³ /h)	0,11818
Control factor CTRL		%	1
Control typology		-	manual
Maximum internal leakage rates		-	NA
Maximum external leakage rates		%	8,8
Mixing rate		-	NA
Position and description of visual filter warning		-	NA
Airflow sensitivity to pressure variations at + 20 Pa and - 20 Pa		m ³ /h	NA
Indoor/outdoor air tightness		-	NA
Annual electricity consumption (AEC)		kWh electricity/a	148
AHS average Annual heating saved		kWh primary energy/a	1715
AHS cold Annual heating saved			2732
AHS warm Annual heating saved			632

* RVU-U: Unit Ventilation Residential - Unidirectional
 ** NRVU-U: Unit Ventilation Non Residential - Unidirectional
 *** MSD: Multi-Speed Drive

DIMENSIONS

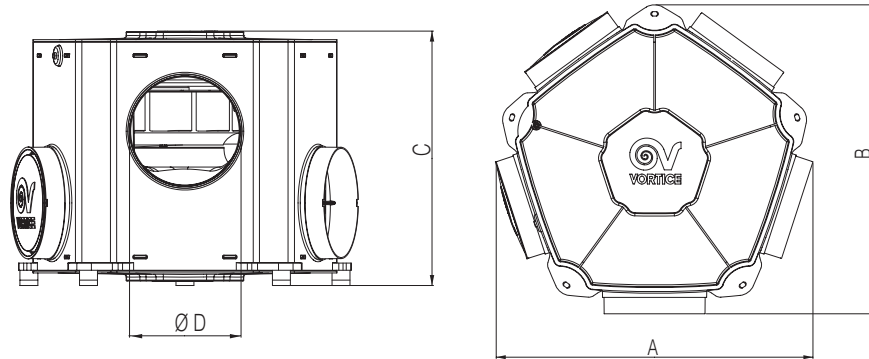



Models	A	B	C	Ø D
VORT LETO MEV	387	377	284	125
VORT LETO MEV RF				

Dimensions (mm)

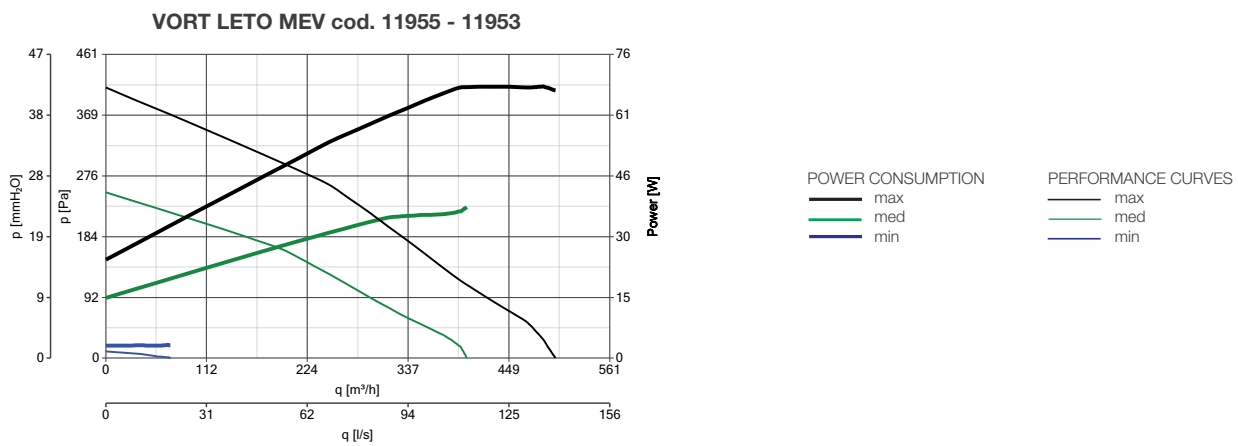
PERFORMANCE CURVES



ACCESSORIES ON REQUEST

Models	Description	Code	Product
	C3VM3 - 3 speed selector controller built-in	12949	11955
	Additional spigot - Hygro 80	22847	All products

Accessories on request (description and technical data on page 146)

APPLICATIONS

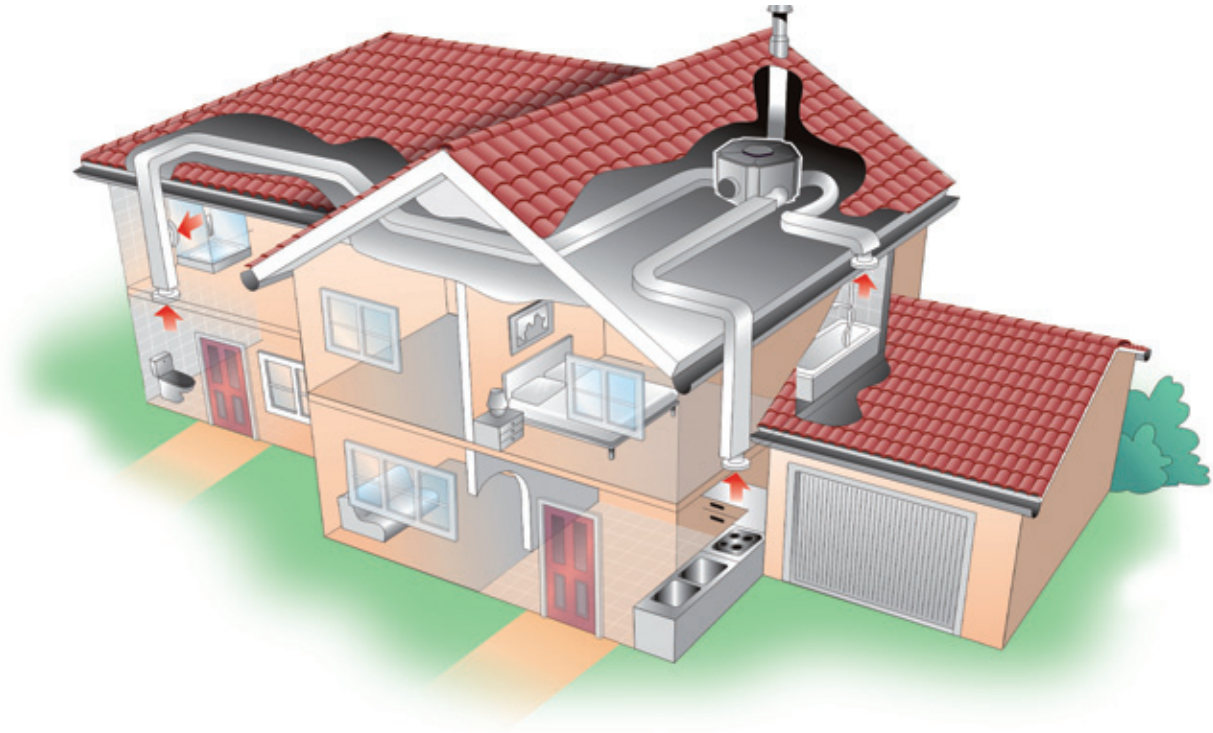



Standard version

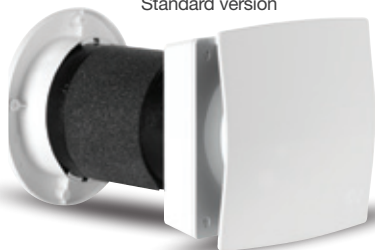

Built-in version



REMOTE CONTROL UNIT
cod. 22693
(only for code 11635)

VORT HRW MONO RANGE

Decentralised continuous axial fans

PRODUCT SPECIFICATIONS

Progettati per assicurare il mantenimento delle condizioni di comfort ideali nel locale asservito, minimizzando al contempo i consumi energetici.

- **3 models:** VORT HRW 20 MONO with operating controls built into the appliance, VORT HRW 20 MONO RC with separate Remote Control unit and VORT HRW 20 MONO HCS with operating controls built into the appliance and humidity sensor.
- Expanded polypropylene (PPE) enclosure.
- Inner panel made of VO self-extinguishing aesthetic plastic polymer (ABS), clad with heat-insulating material.
- EC brushless motor affording high performance and extremely low power consumption; mounting bracket with ball bearings. Very low consumptions (≤ 2 W when running at Min speed, ≤ 5 W when at Max speed), compatible with continuous operation.
- High values of heat transfer efficiency (90% at minimum flow rate according to EN 308), to grant the comfort of users.
- Moulded rubber outer grille, which can be mounted externally with masonry plugs, or inserted internally through the hole prepared in the wall with no need for external scaffolding.
- Elegant aesthetics, perfectly fitting in the residential.
- Small indoor dimensions (240 x 224 x 95 mm version equipped with on-board commands and with humidity sensor, 240 x 224 x 64 mm version controlled through wired control box).
- 5 selectable speeds.
- 3 operating modes for both versions: ventilation with heat recovery; with stale air extraction only; with fresh air supply only.
- Low noise levels (16 dB(A) at Min speed according to DIN 52210-6), compatible with use in studies, bedrooms, living rooms, etc.
- Separate insect mesh, positionable in the duct together with the external grille at the moment of installation.
- Stale internal air extracted around the perimeter of the front panel.
- Outlet port of circular section, nominal diameter 160 mm.
- Washable G3 filter, easily accessible for maintenance purposes.
- HCS models are equipped with a relative humidity sensor (four threshold values: 60%, 70%, 80%, 90%, can be set at installation), which automatically start the extraction mode at max speed when indoor relative humidity exceeds the pre-set limit.
- Factory-prepared for wall wiring
- Diagnostics and filter status Leds.
- Easy to install, set and use..
- No need to install systems for removal of condensate.
- Possibility of operation in automatic mode, enabled by installing optional temperature and relative humidity sensors.
- Protection rating: IPX4.
- Insulation class: II .



TECHNICAL DATA

Models	Code	V~50Hz	W min/max	A min/max	Max Airflow		Max Pressure		Lp dB(A)* 3 m min/max	Max °C	Kg
					m³/h min/max	l/s min/max	mmH ₂ O min/max	Pa min/max			
VORT HRW 20 MONO	11634	220-240	1.0 5.5	0.015 0.053	10 40	2.77 11.10	0.635 4.10	6.22 40.6	<16.0 23.6	30	2,55
VORT HRW 20 MONO RC	11635										2,25
VORT HRW 20 MONO HCS	11631										2,60

* Sound pressure calculated at 3 m distance in free-field out according ISO 9614.

VORT HRW MONO RANGE | TECHNICAL DATA FOR REGULATION N° 1254/2014/UE

	Models Code	Unit of measurement	VORT HRW 20 MONO - VORT HRW 20 MONO RC - VORT HRW 20 MONO HCS
			11634 - 11635 - 11631
Supplier's name or trade mark	-	-	Vortice
Specific Energy Consumption class SEC in average climate zone	-	-	NA
Specific Energy Consumption class SEC average	kWh/m²a	-	-37,2
Specific Energy Consumption class SEC cold		-	-80,8
Specific Energy Consumption class SEC warm		-	-2,2
Declared typology	-	-	RVU-U*
Type of drive	-	-	MSD***
Type of heat recovery system HRS	-	-	Recuperative
Thermal efficiency of heat recovery at reference air flow	%	-	90
Maximum flow rate	m³/s	-	31
Electric power input of the fan drive, including any motor control equipment, at maximum flow rate	W	-	5,1
Sound power level LWA	LWA [dB(A)]	-	44
Reference flow rate	m³/s	-	0,00060
Reference pressure difference	Pa	-	19
SPI	W/(m³/h)	-	0,23963
Control factor CTRL	%	-	1
Control typology	-	-	manual
Maximum internal leakage rates	-	-	NA
Maximum external leakage rates	%	-	NA
Mixing rate	-	-	NA
Position and description of visual filter warning	-	-	NA
Airflow sensitivity to pressure variations at + 20 Pa and - 20 Pa	m³/h	-	0,27
Indoor/outdoor air tightness	-	-	NA
Annual electricity consumption (AEC)	kWh electricity/a	-	330
AHS average Annual heating saved	kWh primary energy/a	-	4550
AHS cold Annual heating saved		-	2732
AHS warm Annual heating saved		-	2057

* RVU-U: Unit Ventilation Residential - Unidirectional
 ** NRVU-U: Unit Ventilation Non Residential - Unidirectional
 *** MSD: Multi-Speed Drive

DIMENSIONS

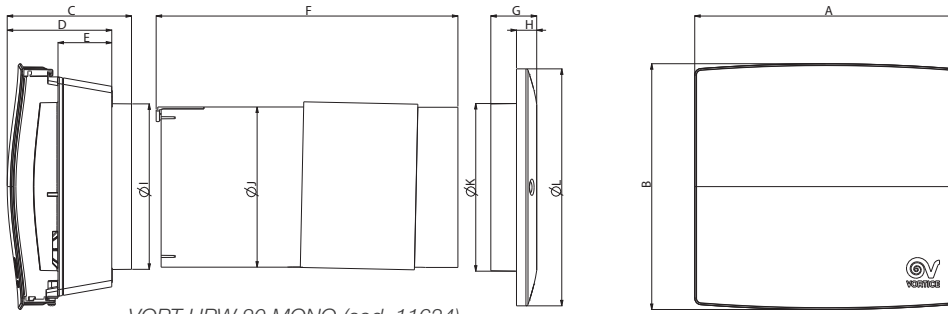

VORT HRW 20 MONO (cod. 11634)
VORT HRW 20 MONO HCS (cod. 11631)

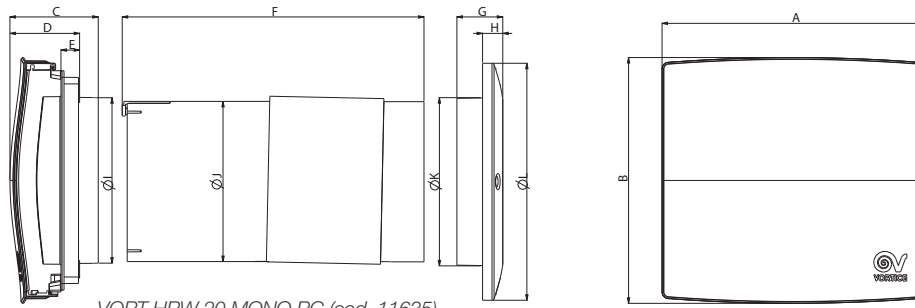

VORT HRW 20 MONO RC (cod. 11635)

Models	A	B	C	D	E	F	G	H	ØI	ØJ	ØK	ØL
VORT HRW 20 MONO	240	224	113	95	49	275	42	18	151	146	153	216
VORT HRW 20 MONO HCS												
VORT HRW 20 MONO RC			80	64	17							

Dimensions (mm)

MAIN COMPONENTS

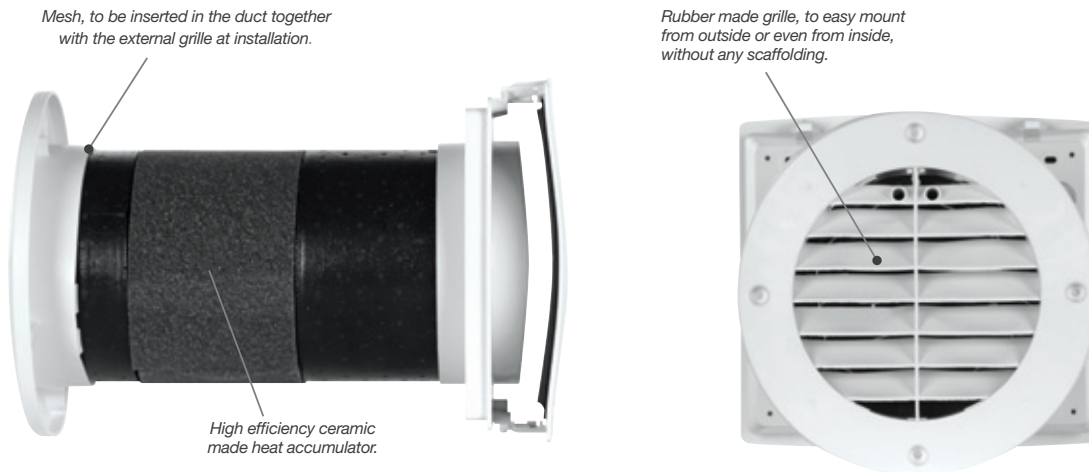

PERFORMANCE CURVES

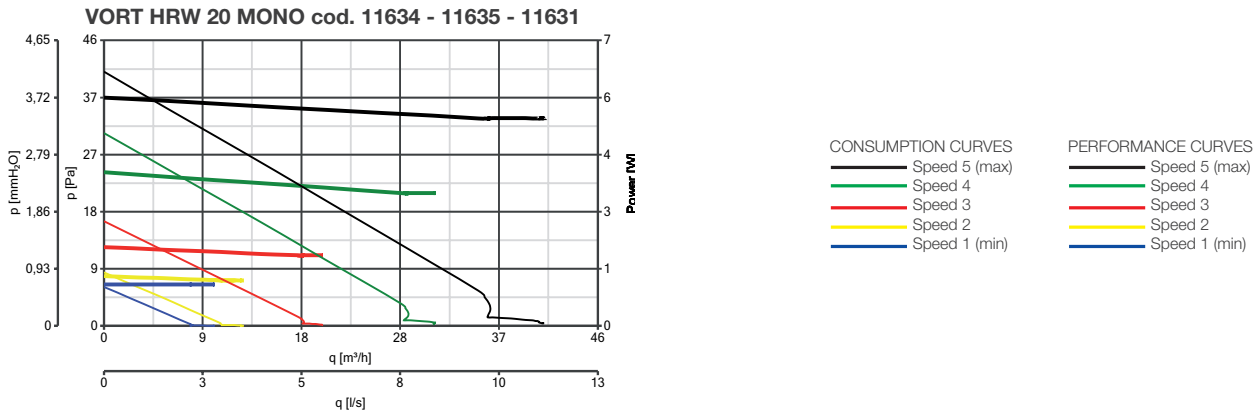

ACCESSORIES ON REQUEST

Models	Description	Code	Product
	Remote Control Unit - Wired control box integrating the power supply (no external device needed), allowing switching on/off and selection of operating mode. Up to 4 products can be wired simultaneously to 1 controller.	22693	11635
	C HCS - Environmental sensor for humidity	12994	11634 - 11635
	PVC Duct Ø 160	22599	All products
	Filter Kit for HRW 20 MONO	22466	All products
	RC Wall-Mounting Kit	22732	All products

Accessories on request (description and technical data on page 146)

CONTROL PANEL VORT HRW 20 MONO E VORT HRW 20 MONO HCS

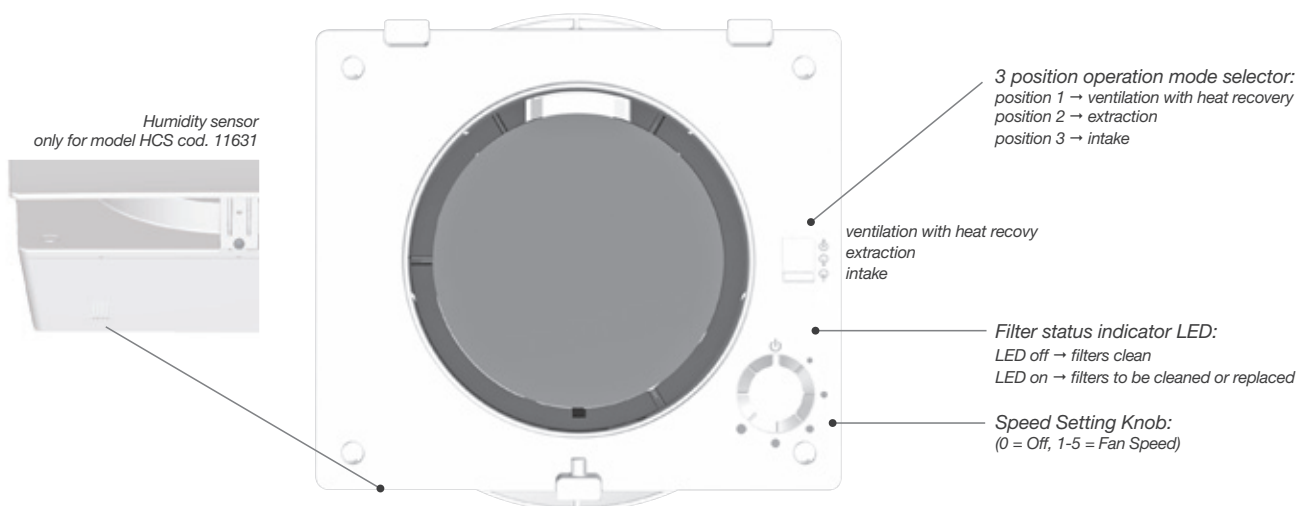



RESIDENTIAL VENTILATION

REMOTE CONTROL UNIT VORT HRW 20 MONO RC

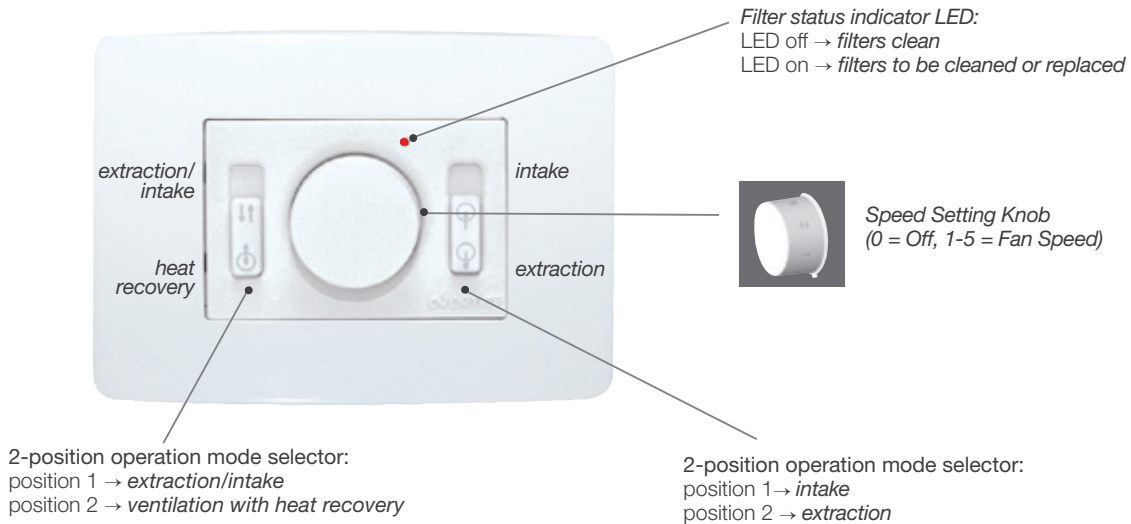

Power supply voltage (V): 220 - 240
Power supply frequency (Hz): 50 Max
Power consumption (W): 18



Available optional ancillaries:
- white face plate code 22462
- anthracite grey face plate code 22463

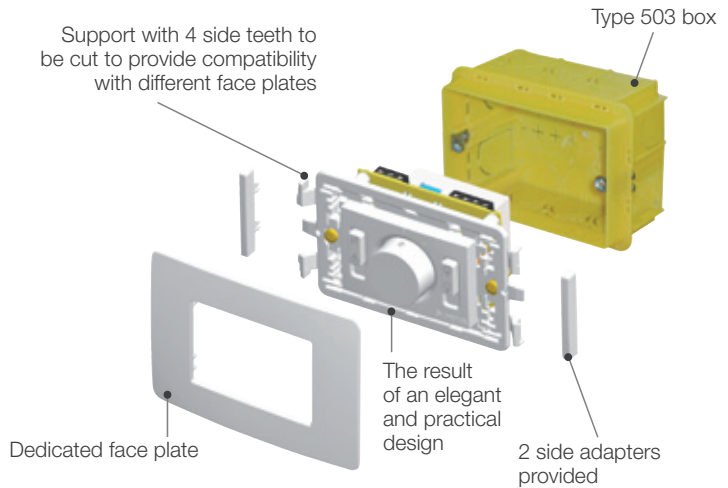

Recessed versions, thanks to an intermediate adjustable support, can be coupled with various existing standard face plates, satisfying diverse aesthetic requirements



APPLICATIONS





Design: F. Trabucco - M. Vecchi



NEW

VORT PRESS EP RANGE

Centrifugal duct fans **LONG LIFE 30.000 h**

PRODUCT SPECIFICATIONS

For the ventilation of medium-sized rooms in commercial applications plus bathrooms, showers, toilets, utilities in domestic situations.

- **2 models**, with or without timer.
- Double motor-fan housing, antivibration supports and backdraught shutter for silent operation.
- Three speeds.
- Motor with ball bearings (guaranteed 30,000 hours of continuous operation) with thermal cut-out.
- Metallic filter which can be removed and washed (dishwasher safe).
- 100 mm dia. outlet spigot.
- Backdraught-shutter to avoid back flow when unit is turned off.
- "Intelligent" timer turns the unit on for approximately 40 sec. after the activation. When switched off, the unit continues to operate at the minimum speed for between 30 sec. and 30 min. (depending on the setting).
- Data and performances IMQ Performance certified.
- Protection rating: IPX4.
- Insulation class: II

Spare Parts

- Metallic anti-dust filter.

TECHNICAL DATA

Models	Code		V~50Hz	W min/max	A min/max	RPM min/max	Max Airflow		Max Pressure		Lp dB(A)* 3 m min/max	Max °C	Kg
	basic	timer					m³/h min/max	l/s min/max	mmH₂O min/max	Pa min/max			
VORT PRESS 220 LL EP	11554	11555	220-240	14 64	0.11 0.42	1200 2380	125 260	35 72	11 35	108 343	43 55	40	2.30

* Conforms with ISO 3744 for noise and pressure levels.

VORT PRESS EP RANGE | TECHNICAL DATA FOR REGULATION N° 1254/2014/UE

	Models Code	Unit of measurement	VORT PRESS 220 LL EP - VORT PRESS 220 LL EP 11554 - 11555
Supplier's name or trade mark		-	Vortice
Declared typology		-	NRVU-U**
Type of drive			VSD***
Type of heat recovery system HRS		-	None
Thermal efficiency of heat recovery		-	NA
Nominal NRVU flow rate		m ³ /s	0,0586
Effective electric power input		kW	0,06
SFPint		W/(m ³ /h)	606,75
Face velocity at desogn flow rate		m/s	7,93134
Nominal external pressure ($\Delta p_{s,int}$)		Pa	110
Internal pressure drop of ventilation components ($\Delta p_{s,int}$)		Pa	160
Internal pressure drop of non-ventilation componenets ($\Delta p_{s,int}$)		Pa	0
Static efficiency of fans used in accordance with Regulation (EU) N. 3272011		%	26,4
Declared maximum internal leakage rate of the casing of ventilation units		%	NA
Declared maximum external leakage rate of the casing of ventilation units		%	NA
Energy performance energy or classification of the filters		-	NA
Description of visual filter warning		%	NA
Casing sound power level (LWA)		dB(A)	76

* RVU-U: Unit Ventilation Residential - Unidirectional

** NRVU-U: Unit Ventilation Non Residential - Unidirectional

*** VSD: Variable-Speed Drive

DIMENSIONS

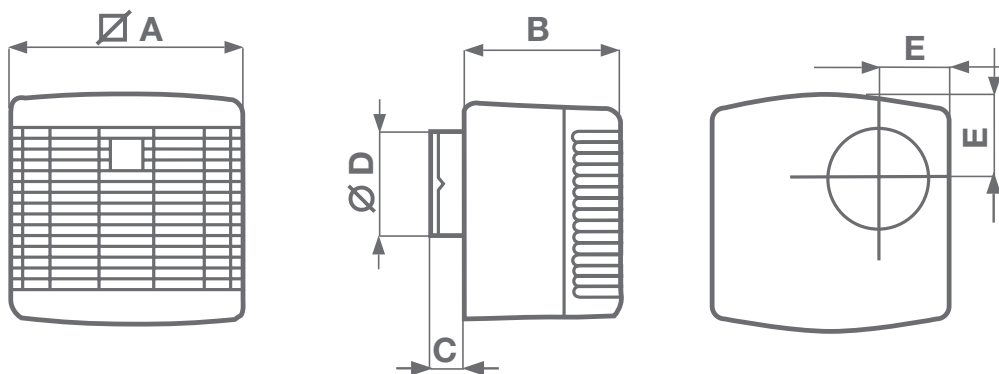

Models	∅ A	B	C	∅ D	E
VORT PRESS 110 LL	202	147	30	97	73
VORT PRESS 220 LL	275	140	28		

Dimensions (mm)

MAIN COMPONENTS

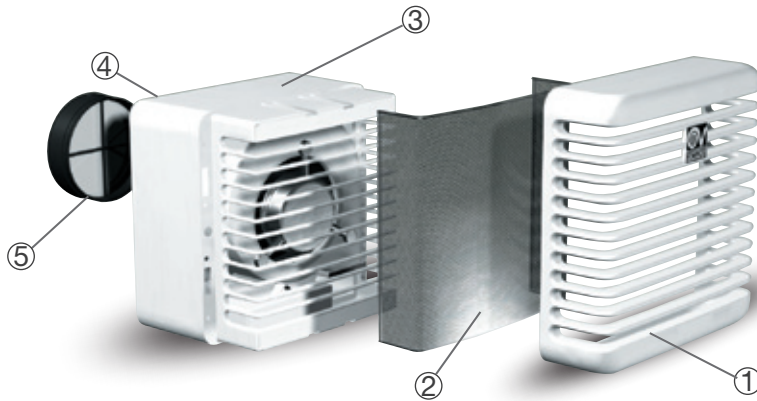

- ① Front grille.
- ② Metallic filter which can be removed and washed (dishwasher safe).
- ③ Made of rigid synthetic resin to guarantee high durability.
- ④ 100 mm dia. outlet spigot.
- ⑤ Silicon backdraught shutter to avoid back-flow when the unit is turned off.

PERFORMANCE CURVES

VORT PRESS 220 LL EP cod. 11554 - 11555

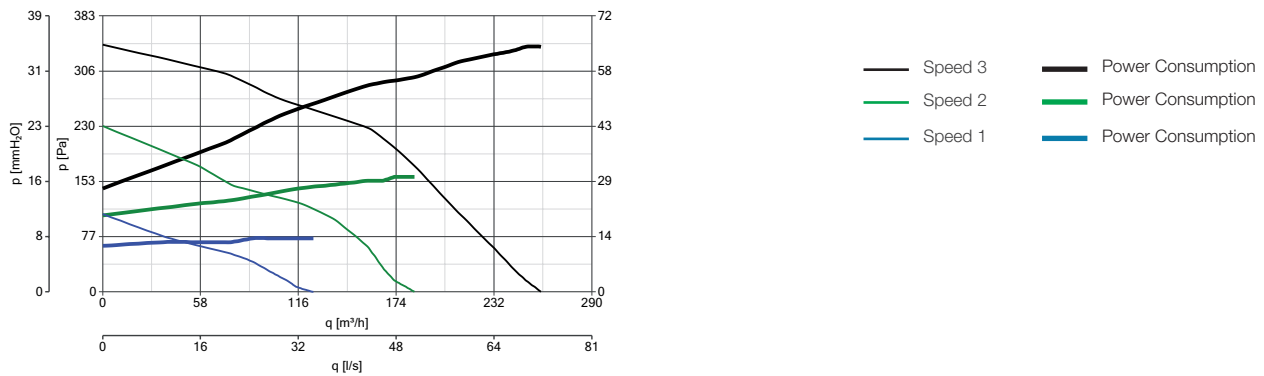

ACCESSORIES ON REQUEST

Models	Description	Code	Product	
	C 1.5 Electronic speed controller 1.5 A	12966	11554	
	SCNRB Electronic speed controller built-in	12971		
	SCB KIT Bult-in controller adaptor for C 1.5	22481	12966	
	Air deflector	10/4	22310	All products

Accessories on request (description and technical data on page 146)

APPLICATIONS





Design: F. Trabucco & Associates (Vort Press I 110)
F. Trabucco - M. Vecchi (Vort Press I 140 /240)



NEW

VORT PRESS I EP RANGE

Centrifugal duct fans for flush mounting **LONG LIFE 30.000 h**

PRODUCT SPECIFICATIONS

For the ventilation of medium-sized or large rooms in commercial applications plus bathrooms, showers, toilets, utilities and kitchens in domestic situations.

- **6 models**, with or without timer.
- Double motor-fan housing, antivibration supports and backdraught shutter for silent operation.
- Three speeds.
- Motor with ball bearings (guaranteed 30,000 hours of continuous operation) with thermal cut-out.
- Unobtrusive front grille.
- Support springs for the front grille, suitable for 65 mm max false ceilings.
- Metallic filter which can be removed and washed (dishwasher safe).
- “Intelligent” timer turns the unit on approximately 40 sec. after the activation. When switched off, the unit continues to operate at the minimum speed for between 30 sec. and 30 min. (depending on the setting).
- 100 mm dia. outlet spigot, all fans have the optional side or rear exit low profile connector, or high profile connector.
- Timer models, the timer is adjustable from 3 to 20 min.
- Data and performances IMQ Performance certified.
- Protection rating: IPX4.
- Insulation class: II

Spare Parts

- Metallic anti-dust filter.

TECHNICAL DATA

Models	Code		V~50Hz	W		A		RPM		Max Airflow				Max Pressure				Lp dB(A)*		Max °C	Kg
	basic	timer		min	max	min	max	min/max ⁽¹⁾	max/max ⁽²⁾	m³/h		l/s		mmH ₂ O		Pa		min	max		
										min/max ⁽¹⁾	max/max ⁽²⁾	min/max ⁽¹⁾	max/max ⁽²⁾	min/max ⁽¹⁾	max/max ⁽²⁾	min/max ⁽¹⁾	max/max ⁽²⁾				
VORT PRESS 240 LL I EP	11552	11553	220-240	12	45	0.1	0.3	1150 2110	1015 1810	140 270	100 210	39 75	28 58	9,1 34,4	8,5 31	89 338	84 304	44	56	40	3.3

⁽¹⁾Rear air outlet. ⁽²⁾Side air outlet with high profile.

VORT PRESS I EP RANGE | TECHNICAL DATA FOR REGULATION N° 1254/2014/UE

	Models Code	Unit of measurement	VORT PRESS 220 LL EP - VORT PRESS 220 LL EP 11554 - 11555
Supplier's name or trade mark		-	Vortice
Declared typology		-	NRVU-U**
Type of drive			VSD***
Type of heat recovery system HRS		-	None
Thermal efficiency of heat recovery		-	NA
Nominal NRVU flow rate		m ³ /s	0,07444
Effective electric power input		kW	0,045
SFPint		W/(m ³ /h)	569,91
Face velocity at design flow rate		m/s	10,07393
Nominal external pressure ($\Delta p_{s,int}$)		Pa	10
Internal pressure drop of ventilation components ($\Delta p_{s,int}$)		Pa	165
Internal pressure drop of non-ventilation components ($\Delta p_{s,int}$)		Pa	0
Static efficiency of fans used in accordance with Regulation (EU) N. 3272011		%	29
Declared maximum internal leakage rate of the casing of ventilation units		%	NA
Declared maximum external leakage rate of the casing of ventilation units		%	NA
Energy performance energy or classification of the filters		-	NA
Description of visual filter warning		%	NA
Casing sound power level (LWA)		dB(A)	56

* RVU-U: Unit Ventilation Residential - Unidirectional

** NRVU-U: Unit Ventilation Non Residential - Unidirectional

*** VSD: Variable-Speed Drive

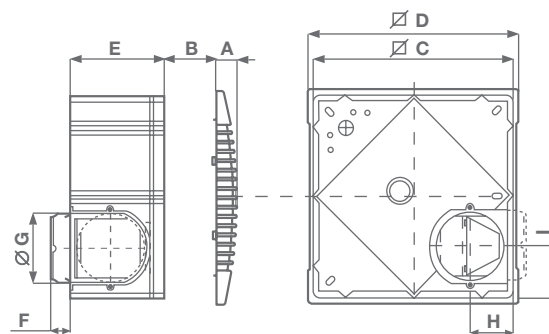
DIMENSIONS

Models	A	Ø B	Ø C	D	E	F	Ø G	H	I
VORT PRESS 140 LL I	28	65	284	300	133	28.5	97	62	71.5
VORT PRESS 240 LL I									

Dimensions (mm)

MAIN COMPONENTS

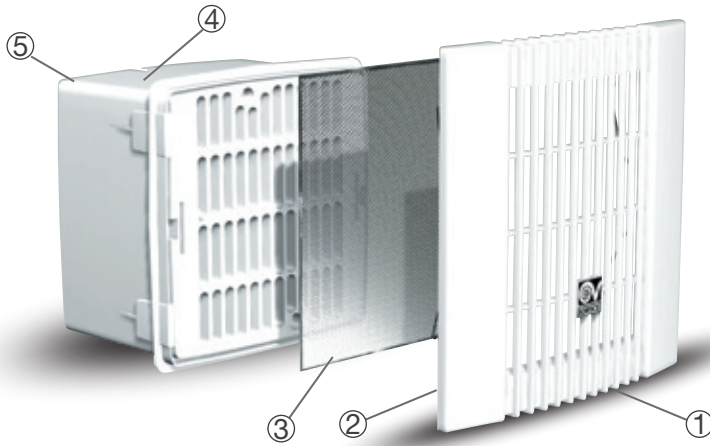

- ① Unobtrusive front grille with support springs which clamp it to the surface, making it suitable for all types of walls and ceilings (max 65 mm).
- ② Metallic filter can be removed and washed (dishwasher safe).
- ③ Made of rigid synthetic resin to guarantee high durability.
- ④ On 110 model, the outlet spigot can be changed to a high or low level spigot.
- ⑤ Silicon backdraught shutter on 140 and 240 models to avoid back flow when unit is turned off.

PERFORMANCE CURVES

VORT PRESS 240 LL I EP cod. 11552 - 11553

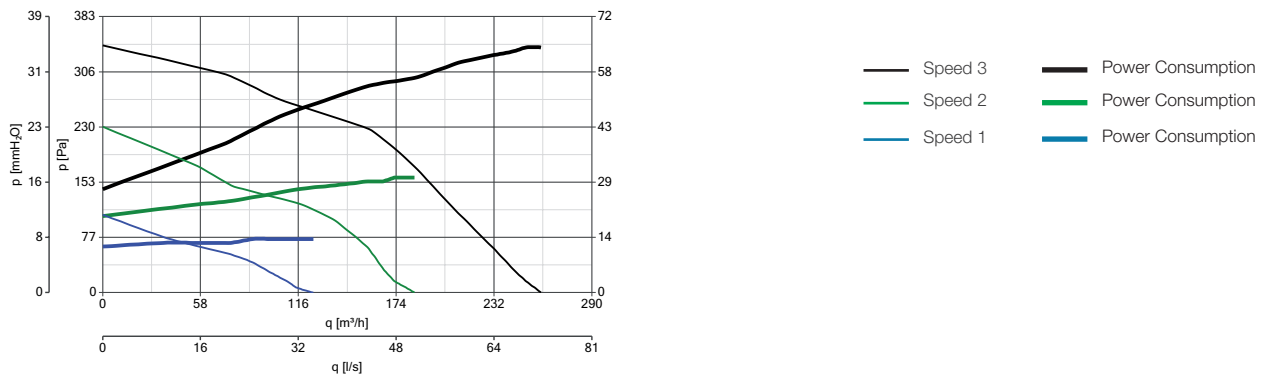

ACCESSORIES ON REQUEST

Models	Description	Code	Product
	C 1.5 Electronic speed controller 1.5 A	12966	11522
	SCNRB Electronic speed controller built-in	12971	
	SCB KIT Bult-in controller adaptor for C 1.5	22481	12966
	Air deflector	10/4	22310
	High profile connector		
	False-ceiling/wall installation kit	22823	22823
		22815	11522 - 11553
	Horizontal Outlet - Low Profile	22842	All Products
	Horizontal Outlet - High Profile	22823	All Products

Accessories on request (description and technical data on page 146)

APPLICATIONS

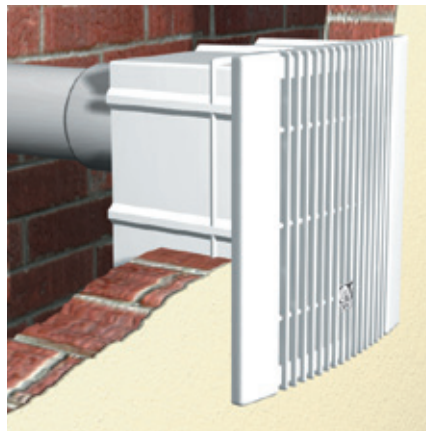
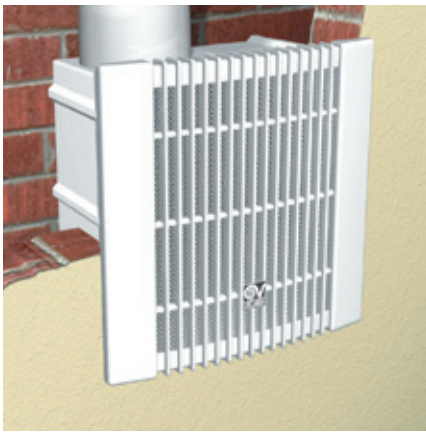



Design: F. Trabucco - M. Vecchi



NEW

VORT KAPPA EP

Centrifugal canopy fan

For use when ventilating over a cooker in the kitchen.

- **1 model.**
- Automatic backdraught shutter to avoid back flow when unit is turned off.
- Three speeds.
- Metal body and motor-holder.
- Heat-resistant.
- Quick and easy installation and maintenance.
- Insulation class: I ⊕.
- Protection rating: IPX0.

Spare parts

- Metallic anti-dust filter.

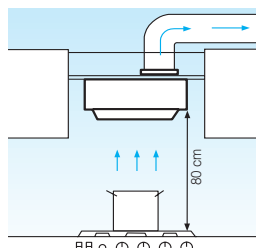

TECHNICAL DATA

Models	Code	V~50Hz min/max	W min/max	A min/max	RPM min/max	Max Airflow		Max Pressure		Lp dB(A)* 3 m min/max	Kg
						m³/h min/max	l/s min/max	mmH₂O min/max	Pa min/max		
VORT KAPPA EP	10951	220 - 240	12 60	0.09 0.40	1050 2270	100 270	28 75	7,3 35,5	72 348	35.8 55.3	2,7

* Conforms with ISO 3744 for noise and pressure levels.

VORT KAPPA EP | TECHNICAL DATA FOR REGULATION N° 1254/2014/UE

	Models Code	Unit of measurement	VORT KAPPA EP 10951
Supplier's name or trade mark		-	Vortice
Declared typology		-	NRVU-U**
Type of drive			VSD***
Type of heat recovery system HRS		-	None
Thermal efficiency of heat recovery		-	NA
Nominal NRVU flow rate		m ³ /s	0,06139
Effective electric power input		kW	0,057
SFPint		W/(m ³ /h)	NA
Face velocity at design flow rate		m/s	8,32
Nominal external pressure ($\Delta p_{s,int}$)		Pa	119
Internal pressure drop of ventilation components ($\Delta p_{s,int}$)		Pa	116
Internal pressure drop of non-ventilation components ($\Delta p_{s,int}$)		Pa	0
Static efficiency of fans used in accordance with Regulation (EU) N. 3272011		%	25,3
Declared maximum internal leakage rate of the casing of ventilation units		%	NA
Declared maximum external leakage rate of the casing of ventilation units		%	NA
Energy performance energy or classification of the filters		-	NA
Description of visual filter warning		%	NA
Casing sound power level (LWA)		dB(A)	76

* RVU-U: Unit Ventilation Residential - Unidirectional
 ** NRVU-U: Unit Ventilation Non Residential - Unidirectional
 *** VSD: Variable-Speed Drive

DIMENSIONS

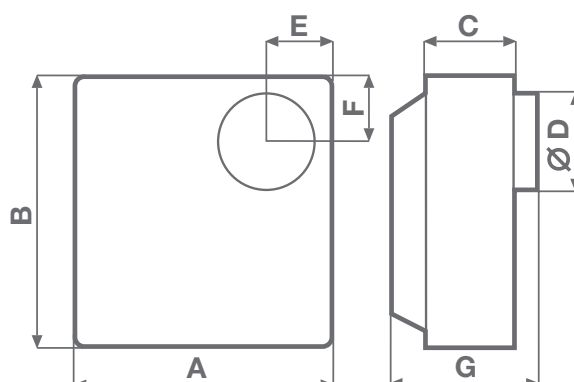

Models	A	B	C	$\varnothing D$	E	F	G
VORT KAPPA	252	270	90	97	65	65	145



Dimensions (mm)

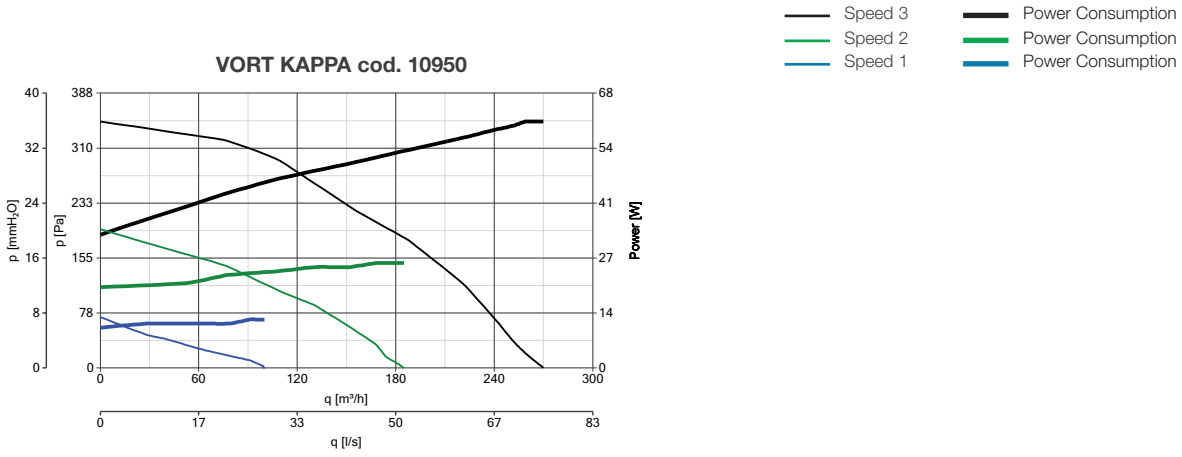

PERFORMANCE CURVES



ACCESSORIES ON REQUEST

Models	Description	Code	Product	
	C 1.5 Electronic speed controller 1.5 A	12966	10950	
	SCNRB Electronic speed controller built-in	12971		
	SCB KIT Bult-in controller adaptor for C 1.5	22481	12966	
	Air deflector	10/4	22310	10950

Accessories on request (description and technical data on page 146)



Design: F. Trabucco & Associates



NEW

VORT QUADRO EP AC RANGE

Centrifugal duct fans

PRODUCT SPECIFICATIONS

For the ventilation of medium-sized or large rooms in commercial premises plus bathrooms, showers, toilets, utilities and kitchens in domestic situations.

- **6 models:** 4 with or without timer and incorporated humidistat, 2 high-efficiency EC-DC brushless motor.
- Two Speeds. All models feature two speed operation, including timer equipped models.
- Motor with thermal cut-out incorporated.
- Backdraught shutter already installed on the product to avoid air back-flow when the unit is turned off.
- Vort Quadro fans guarantee a low environmental impact. Recyclable materials have been used and the "Design for Disassembly" technique has been followed.
- The units have a high extraction to long ducts are used. Reduced sound levels with superior certified performances on ducted applications.
- The energy saving can be really significant in case of continuous operation of the fan.
- It will also permit power savings associated with the recovery of heat.
- Timer models adjustable between 3 and 20 min.
- T-HCS model, adjustable RH threshold at 60%, 70%, 80%, 90% by mean of a slide switch during installation. The product automatically switches on when the indoor relative humidity level exceeds the pre-set value.
- Filter can be removed and washed.
- Easy to install and maintain.
- Data and performances IMQ Performance certified.
- Protection rating: IPX4.
- Insulation class: II □.

RANGE

TIMER

T-HCS Humidity Control System - Timer

MEDIO EP AC	12020 MEDIO EP AC	12121 MEDIO EP AC T	12122 MEDIO EP AC THCS
SUPER EP AC	12130 SUPER EP AC	12131 SUPER EP AC T	12132 SUPER EP AC THCS

TECHNICAL DATA

Models	V~50Hz	W min/max	A min/max	RPM min/max	Max Airflow		Max Pressure		Lp dB(A)* 3 m min/max	Max °C	Kg
					m³/h min/max	l/s min/max	mmH ₂ O min/max	Pa min/max			
MEDIO EP AC	220-240	45 60	0.21 0.27	1200 1600	130 180	36 50	34 37	334 363	33,4 39,6	40	2.77
SUPER EP AC		65 95	0.30 0.48	1400 2040	185 270	51 75	42 50	412 491	41.9 48.6	50	3.77



VORT QUADRO EP RANGE | TECHNICAL DATA FOR REGULATION N° 1254/2014/UE

	Models Code	Unit of measurement	MEDIO EP AC 12020 - 12121 - 12122
Supplier's name or trade mark	-	-	Vortice
Specific Energy Consumption class SEC in average climate zone	-	-	NA
Specific Energy Consumption class SEC average	kWh/m²a		0
Specific Energy Consumption class SEC cold			-14
Specific Energy Consumption class SEC warm			7
Declared typology	-	-	RVU-U*
Type of drive	-	-	MSD
Type of heat recovery system HRS	-	-	None
Thermal efficiency of heat recovery at reference air flow	%		NA
Maximum flow rate	m³/s		103
Electric power input of the fan drive, including any motor control equipment, at maximum flow rate	W		29,4
Sound power level LWA	LWA [dB(A)]		64
Reference flow rate	m³/s		0,02
Reference pressure difference	Pa		141
SPI	W/(m³/h)		0,398
Control factor CTRL	%		1
Control typology	-	-	manual
Maximum internal leakage rates	-	-	NA
Maximum external leakage rates	%		NA
Mixing rate	-	-	NA
Airflow sensitivity to pressure variations at + 20 Pa and - 20 Pa	m³/h		0,10
Indoor/outdoor air tightness	-	-	NA
Annual electricity consumption (AEC)	kWh electricity/a		549
AHS average Annual heating saved	kWh primary energy/a		1397
AHS cold Annual heating saved			2732
AHS warm Annual heating saved			632
Position and description of visual filter warning	-	-	NA

* RVU-U: Unit Ventilation Residential - Unidirectional

** NRVU-U: Unit Ventilation Non Residential - Unidirectional

*** MSD: Multi-Speed Drive

	Models Code	Unit of measurement	SUPER EP AC 12130 - 12131 - 12132
Supplier's name or trade mark	-	-	Vortice
Declared typology	-	-	NRVU-U**
Type of drive	-	-	VSD***
Type of heat recovery system HRS	-	-	None
Thermal efficiency of heat recovery	-	-	NA
Nominal NRVU flow rate	m³/s		0,05556
Effective electric power input	kW		0,090
SFPint	W/(m³/h)		NA
Face velocity at design flow rate	m/s		7,528
Nominal external pressure (Δps,int)	Pa		200
Internal pressure drop of ventilation components (Δps,int)	Pa		245
Internal pressure drop of non-ventilation components (Δps,int)	Pa		0
Static efficiency of fans used in accordance with Regulation (EU) N. 3272011	%		27,5
Declared maximum internal leakage rate of the casing of ventilation units	%		NA
Declared maximum external leakage rate of the casing of ventilation units	%		NA
Energy performance energy or classification of the filters	-	-	NA
Description of visual filter warning	%		NA
Casing sound power level (LWA)	dB(A)		69

* RVU-U: Unit Ventilation Residential - Unidirectional

**NRVU-U: Unit Ventilation Non Residential - Unidirectional

***VSD: Variable-Speed Drive



RESIDENTIAL VENTILATION

DIMENSIONS

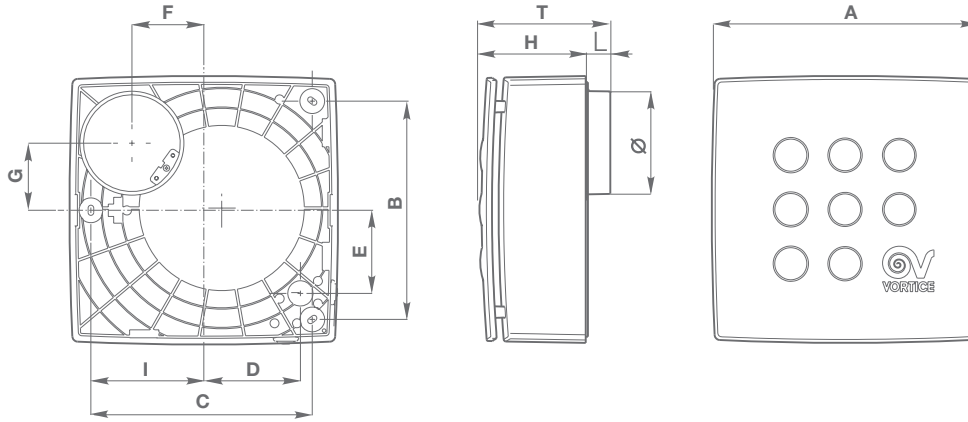

Models	A	B	C	D	E	F	G	H	I	L	T	Ø
MEDIO EP AC	261	212	215	95	82	75	69	119	110	20	138	92.5/97
SUPER EP AC	290	236	239	108	92	87	81	144	125		164	

Dimensions (mm)

PERFORMANCE CURVES

— Speed 3 — Power Consumption
 — Speed 2 — Power Consumption
 — Speed 1 — Power Consumption

— Speed 4 — Power Consumption
 — Speed 3 — Power Consumption
 — Speed 2 — Power Consumption
 — Speed 1 — Power Consumption

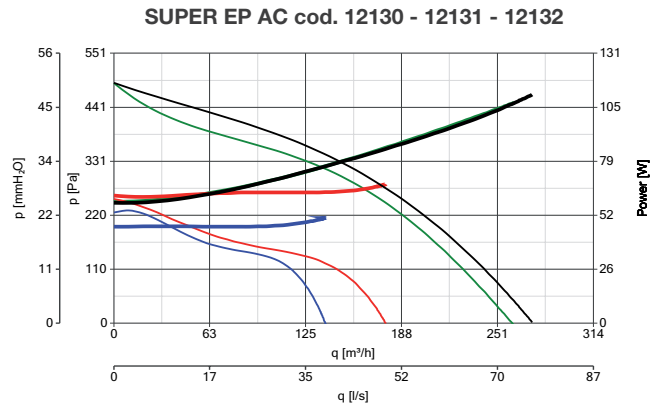
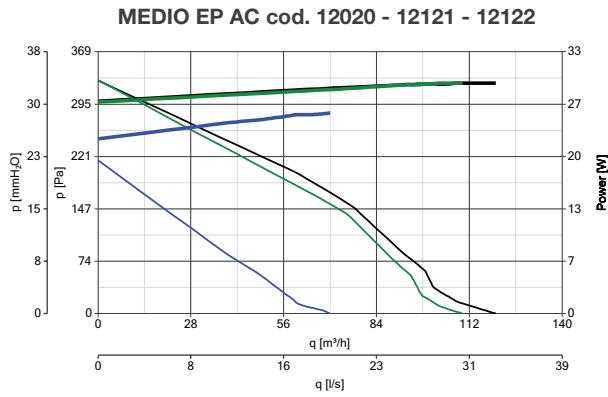

ACCESSORIES ON REQUEST

Models	Description	Code	Product	
	C 1.5 Electronic speed controller 1.5 A	12966	12090 - 12110	
	SCNRB Electronic speed controller built-in	12971		
	SCB KIT Bult-in controller adaptor for C 1.5	22481	12966	
	Air deflector	10/4	22310	All products

Accessories on request (description and technical data on page 146)

APPLICATIONS

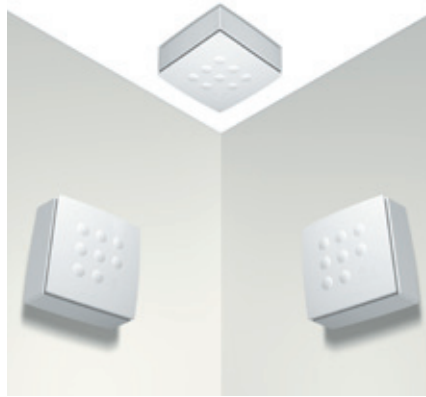



Design: F. Trabucco & Associates



NEW

VORT QUADRO I EP AC RANGE

Centrifugal duct fans for flush mounting

PRODUCT SPECIFICATIONS

For the ventilation of medium-sized or large rooms in commercial premises plus bathrooms, showers, toilets, utilities and kitchens in domestic situations.

- **6 models:** 4 with or without timer and incorporated humidistat.
- Flush mounting.
- Two Speeds. All models feature two speed operation, including timer equipped models.
- Motor with thermal cut-out incorporated.
- Backdraught shutter already installed on the product to avoid air back-flow when the unit is turned off.
- The units have a high extraction to long ducts are used. Reduced sound levels with superior certified performances on ducted applications.
- The energy saving can be really significant in case of continuous operation of the fan.
- It will also permit power savings associated with the recovery of heat.
- Timer models adjustable between 3 and 20 min.
- T-HCS model, adjustable RH threshold at 60%, 70%, 80%, 90% by mean of a slide switch during installation. The product automatically switches on when the indoor relative humidity level exceeds the pre-set value
- Filter can be removed and washed.
- Easy to install and mantain.
- Data and performances IMQ Performance certified.
- Protection rating: IPX4.
- Insulation class: II □.

RANGE

TIMER

T-HCS Humidity Control System - Timer

MEDIO I EP AC	12123 MEDIO I EP AC	12124 MEDIO I EP AC T	12125 MEDIO I EP AC THCS
SUPER I EP AC	12133 SUPER I EP AC	12134 SUPER I EP AC T	12135 SUPER I EP AC THCS

TECHNICAL DATA

Models	V~50Hz	W min/max	A min/max	RPM min/max	Max Airflow		Max Pressure		Lp dB(A)*3 m min/max	Max °C	Kg
					m ³ /h min/max	l/s min/max	mmH ₂ O min/max	Pa min/max			
MEDIO I EP AC	220-240	25 29	0.14 0.18	1000 1300	70 122	19,4 33,9	21 33,7	206 331	36 41,3	50	2.80
SUPER I EP AC		50 115	0.36 0.50	1280 2190	140 285	39 79	20 48	196 471	33,6 46,7		

VORT QUADRO I EP AC RANGE | TECHNICAL DATA FOR REGULATION N° 1254/2014/UE

	Models Code	Unit of measurement	MEDIO I EP AC 12123 - 12124 - 12125
Supplier's name or trade mark	-	-	Vortice
Specific Energy Consumption class SEC in average climate zone	-	-	NA
Specific Energy Consumption class SEC average	kWh/m ² a	-	-1
Specific Energy Consumption class SEC cold		-	-14
Specific Energy Consumption class SEC warm		-	7
Declared typology	-	-	RVU-U*
Type of drive	-	-	MSD
Type of heat recovery system HRS	-	-	None
Thermal efficiency of heat recovery at reference air flow	%	-	NA
Maximum flow rate	m ³ /s	-	106
Electric power input of the fan drive, including any motor control equipment, at maximum flow rate	W	-	29,6
Sound power level LWA	LWA [dB(A)]	-	62
Reference flow rate	m ³ /s	-	0,0205
Reference pressure difference	Pa	-	196
SPI	W/(m ³ /h)	-	0,384
Control factor CTRL	%	-	1
Control typology	-	-	manual
Maximum internal leakage rates	-	-	NA
Maximum external leakage rates	%	-	NA
Mixing rate	-	-	NA
Airflow sensitivity to pressure variations at + 20 Pa and - 20 Pa	m ³ /h	-	0,06
Indoor/outdoor air tightness	-	-	NA
Annual electricity consumption (AEC)	kWh electricity/a	-	529
AHS average Annual heating saved	kWh primary energy/a	-	1397
AHS cold Annual heating saved		-	2732
AHS warm Annual heating saved		-	632
Position and description of visual filter warning	-	-	NA

* RVU-U: Unit Ventilation Residential - Unidirectional

** NRVU-U: Unit Ventilation Non Residential - Unidirectional

*** MSD: Multi-Speed Drive

	Models Code	Unit of measurement	SUPER I EP AC 12133 - 12134 - 12135
Supplier's name or trade mark	-	-	Vortice
Declared typology	-	-	NRVU-U**
Type of drive	-	-	VSD***
Type of heat recovery system HRS	-	-	None
Thermal efficiency of heat recovery	-	-	NA
Nominal NRVU flow rate	m ³ /s	-	0,05833
Effective electric power input	kW	-	0,095
SFPint	W/(m ³ /h)	-	NA
Face velocity at design flow rate	m/s	-	7,894
Nominal external pressure (Δps,int)	Pa	-	205
Internal pressure drop of ventilation components (Δps,int)	Pa	-	245
Internal pressure drop of non-ventilation components (Δps,int)	Pa	-	0
Static efficiency of fans used in accordance with Regulation (EU) N. 3272011	%	-	27,6
Declared maximum internal leakage rate of the casing of ventilation units	%	-	NA
Declared maximum external leakage rate of the casing of ventilation units	%	-	NA
Energy performance energy or classification of the filters	-	-	NA
Description of visual filter warning	-	-	NA
Casing sound power level (LWA)	dB(A)	-	67

* RVU-U: Unit Ventilation Residential - Unidirectional

**NRVU-U: Unit Ventilation Non Residential - Unidirectional

***VSD: Variable-Speed Drive



RESIDENTIAL VENTILATION

DIMENSIONS

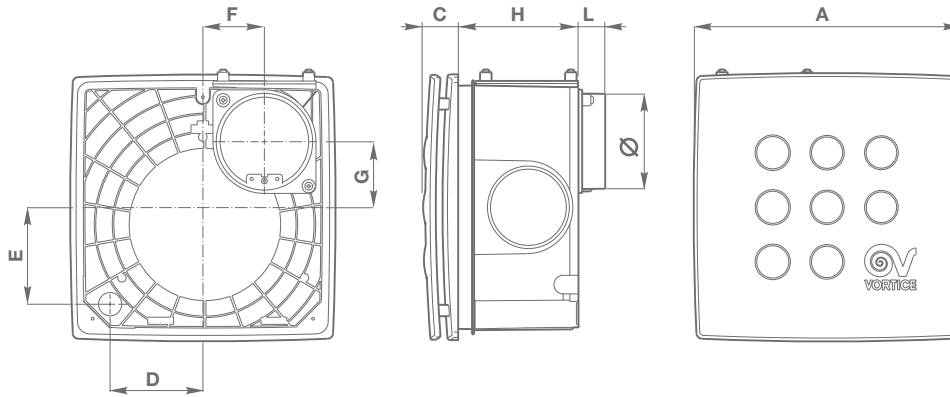

Models	A	C	D	E	F	G	H	L	Ø
MEDIO I EP AC	287	37	97	103	72	69	130	26	92,5/97
SUPER I EP AC	314	38	120	120	80	81	153		

Dimensions (mm)

PERFORMANCE CURVES



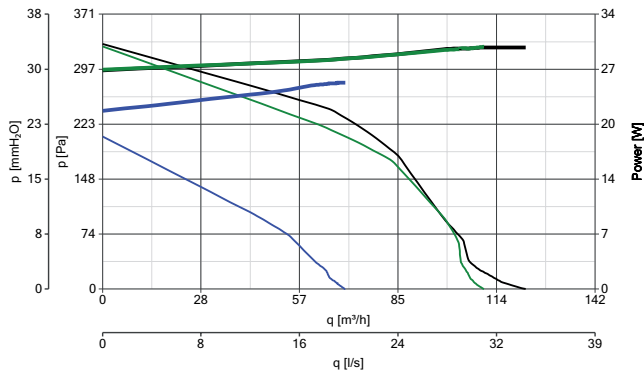

MEDIO I EP AC cod. 12123 - 12124 - 12125

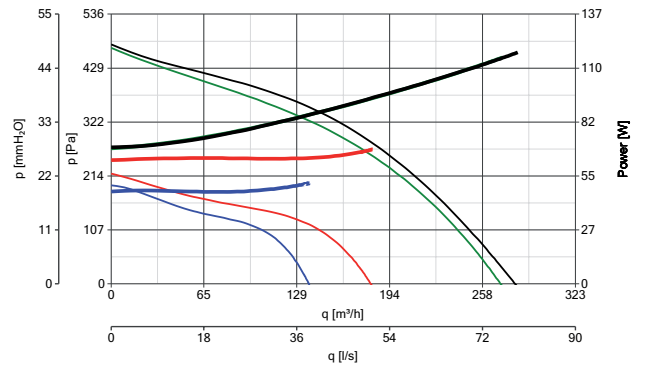

SUPER I EP AC cod. 12133 - 12134 - 12135



ACCESSORIES ON REQUEST

Models	Description	Code	Product	
	C 1.5 Electronic speed controller 1.5 A	12966	12123 - 12133	
	SCNRB Electronic speed controller built-in	12971		
	SCB KIT Bult-in controller adaptor for C 1.5	22481	12966	
	Air deflector	10/4	22310	All products
	Ceiling Kit	MEDIO	22492	12123 - 12124 - 12125
		SUPER	22493	12133 - 12134 - 12135

Accessories on request (description and technical data on page 146)

APPLICATIONS





NEW

VORT PLATT EP RANGE

Centralised continuous ventilation units



PRODUCT SPECIFICATIONS

Suitable for horizontal and vertical installations on walls, ceilings and false ceiling.

- **2 models:** VORT PLATT, VORT PLATT ES.
- Designed to guarantee efficient ventilation of the home in continuous operating mode.
- Long lasting galvanized steel cover.
- Rear flange made of ABS.
- Ball bearing motor.
- Two speeds.
- Inlets: 3 x 80 mm + 1 x 125 mm diameter.
- Outlet: 1 x 125 mm diameter.
- Protection rating: IPX4.
- Insulation class: II .

VORT PLATT

- AC motor external rotor with thermally protected.
- VORT PLATT supplied with 2 spigots (30 m³/h) and 1 blank.

VORT PLATT ES:

- Electrically controlled EC brushless motors offer optimal performance and extremely low energy consumption.
- 3 alternative settings selectable by dip switch.
- Very high efficiency: specific fan power down to 0.2 [W/l/s].
- Timer 30'.
- VORT PLATT ES supplied with 2 spigots and 1 blank.



TECHNICAL DATA

Models	Code	V~50Hz	W min/max	A min/max	RPM min/max	Max Airflow		Max Pressure		Lp dB(A)* 3 m min/max	Max °C	Kg
						m ³ /h min/max	l/s min/max	mmH ₂ O min/max	Pa min/max			
VORT PLATT EP	11366	230	20 56	0.01 0.25	1300 2610	176 343	48.8 95.2	26.6 41.9	261.0 411.7	- 34.9+	60	5,4
VORT PLATT ES EP	11556		12 50	0.12 0.45	830 1400	215 365	60 101	5 14.5	49 142	26.5** 36	50	4

*Vort Platt Ep dB(A) measured at kitchen port at minimum speed.

** Vort Platt ES Ep: Lp dB(A) 3 m measured in configuration 3+1.



VORT PLATT EP RANGE | TECHNICAL DATA FOR REGULATION N° 1254/2014/UE

	Models Code	Unit of measurement	VORT PLATT EP	VORT PLATT ES
			11366	11556
Supplier's name or trade mark	-	-	Vortice	Vortice
Specific Energy Consumption class SEC in average climate zone	-	-	E	E
Specific Energy Consumption class SEC average	kWh/m ² a		-11,6	-13.4
Specific Energy Consumption class SEC cold			-21,2	-23.2
Specific Energy Consumption class SEC warm			-0.2	-2.2
Declared typology	-	-	RVU-U*	RVU-U*
Type of drive	-	-	MSD***	MSD***
Type of heat recovery system HRS	-	-	None	None
Thermal efficiency of heat recovery at reference air flow	%		NA	NA
Maximum flow rate	m ³ /s		280	0,0661
Electric power input of the fan drive, including any motor control equipment, at maximum flow rate	W		57,6	32
Sound power level LWA	LWA [dB(A)]		35	43
Reference flow rate	m ³ /s		0,0544	0,0463
Reference pressure difference	Pa		100	95
SPI	W/(m ³ /h)		0,17755	0,12005
Control factor CTRL	%		1	1
Control typology	-		manual	manual
Maximum internal leakage rates	-		NA	NA
Maximum external leakage rates	%		7,4	7,4
Mixing rate	-		NA	NA
Airflow sensitivity to pressure variations at + 20 Pa and - 20 Pa	m ³ /h		NA	NA
Indoor/outdoor air tightness	-		NA	NA
Annual electricity consumption (AEC)	kWh electricity/a		2223	150
AHS average Annual heating saved	kWh primary energy/a		1715	1715
AHS cold Annual heating saved		2732	2732	
AHS warm Annual heating saved		632	632	
Position and description of visual filter warning	-		NA	NA

* RVU-U: Unit Ventilation Residential - Unidirectional
 ** NRVU-U: Unit Ventilation Non Residential - Unidirectional
 *** MSD: Multi-Speed Drive



RESIDENTIAL VENTILATION

DIMENSIONS

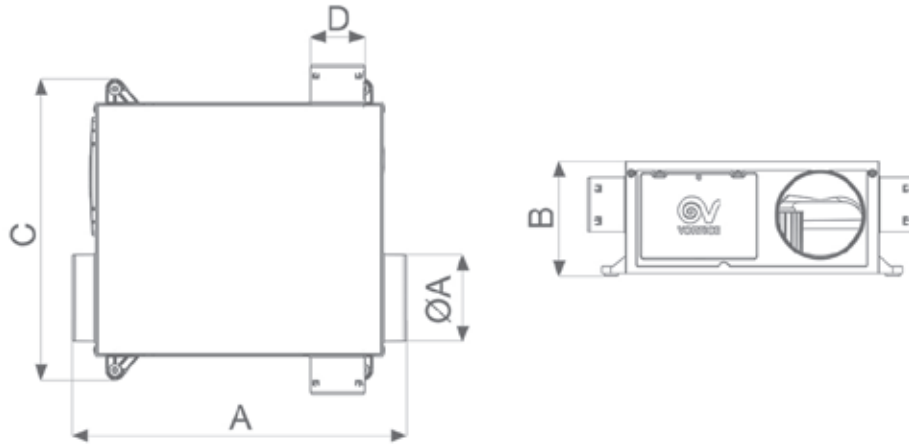

Models	Ø A	A	B	C	D
VORT PLATT EP	124,5	478	164	430	77,5
VORT PLATT EP ES					

Dimensions (mm)

PERFORMANCE CURVES

POWER CONSUMPTION: Max speed (black), Min speed (green), Min speed (blue)
 PERFORMANCE CURVES: Max speed (black), Min speed (green), Min speed (blue)

VORT PLATT EP - cod. 11677

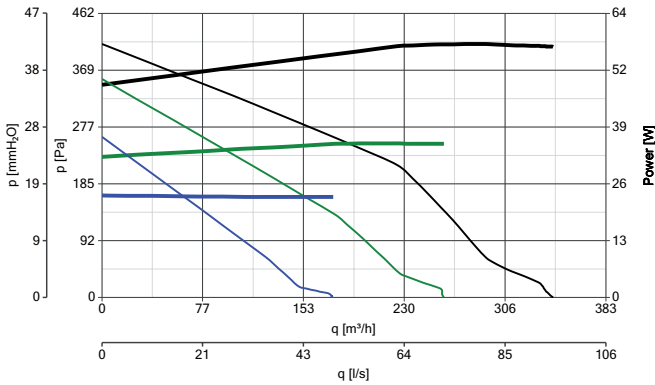

VORT PLATT ES EP - cod. 11366

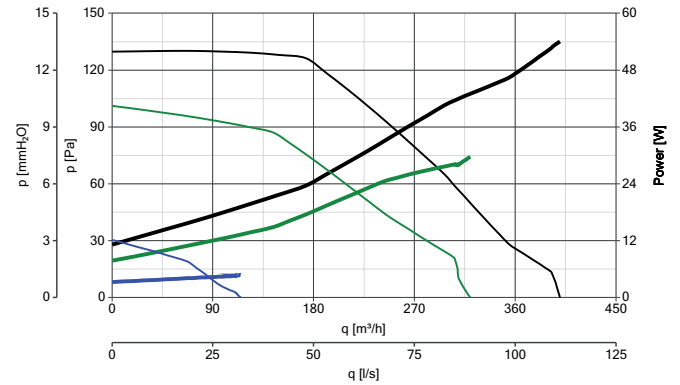

ACCESSORIES ON REQUEST

Models	Description	Code	Product
	Regulator	15 ³ /h	22324
		30 ³ /h	22325
	Additional spigot - Hygro 80	22847	All products

Accessories on request (description and technical data on page 146)

APPLICATIONS

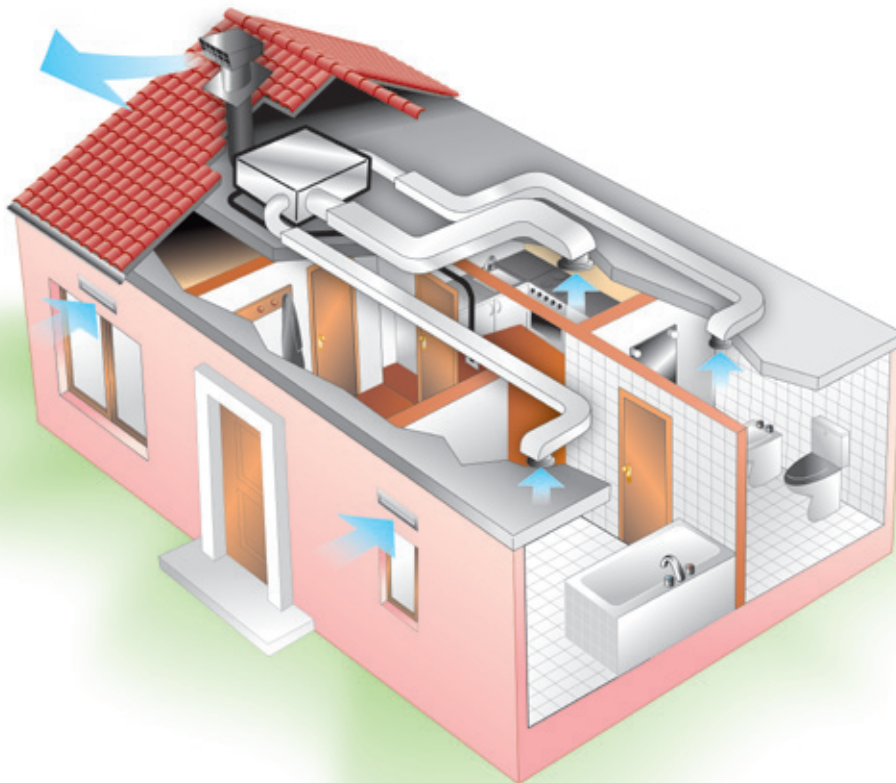
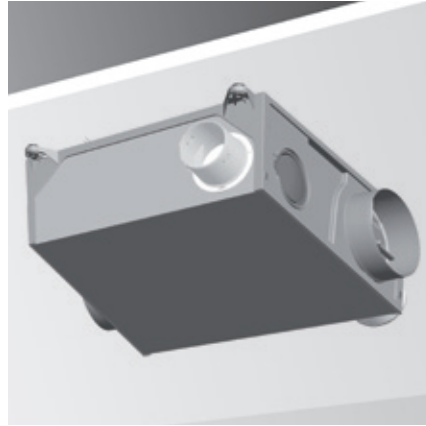
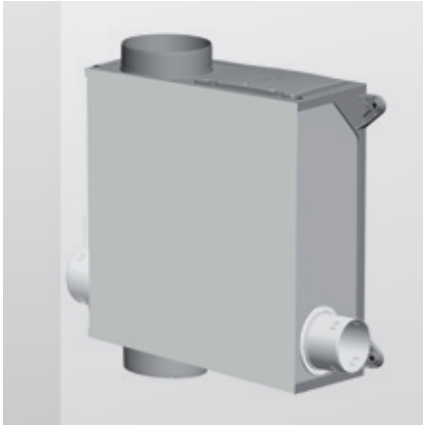



NEW

VORT PENTA EP RANGE

Centralised continuous ventilation units

PRODUCT SPECIFICATIONS

Designed to guarantee efficient ventilation of the home in continuous operating mode. Extraction up to 6 rooms.

- **2 models:** VORT PENTA, VORT PENTA ES.
- ABS made.
- Ball bearing motor.
- Two speeds.
- Inlets: 5 x 80 mm + 1 x 125 mm diameter.
- Outlet: 1 x 125 mm diameter.
- New time-saving automatic kitchen flow regulation.
- Internal ducting designed to guarantee high performance, low consumption and reduced noise levels.
- Designed for installation in false ceilings, these are set up for suspended mounting by means of a cord supplied as standard.
- Alternatively, the integrated rotating bracket is available; this makes the fan very easy to install in any position, as it ensures the setup is suited to system requirements.
- Protection rating: IPX4.
- Insulation class: II □.

Vort Penta EP

- AC motor.
- Supplied with 2 spigots (30 m³) and 4 blanks.

Vort Penta ES EP

- Electrically controlled EC brushless motors offer optimal performance and extremely low energy consumption.
- 5 alternative settings selectable by dip switch.
- Very high efficiency: specific fan power down to 0.2 [W/l/s].
- Timer 30'.
- Supplied with 3 spigots and 3 blanks.



TECHNICAL DATA

Models	Code	V~50Hz	W min/max	A min/max	RPM min/max	Max Airflow		Max Pressure		Lp dB(A)* 3 m min/max	Max °C	Kg
						m ³ /h min/max	l/s min/max	mmH ₂ O min/max	Pa min/max			
VORT PENTA EP	11509	230	21 73	0.18 0.34	1245 2160	206 340	59,9 94,4	24,4 43,0	240,1 421,9	- 31,9	40	4,4
VORT PENTA ES EP	11557		5 35	0.13 0.31	750 2018	123 380	34,1 105,5	3,6 28,0	35,42 275,5	35 43	50	4,0



VORT PENTA EP RANGE | TECHNICAL DATA FOR REGULATION N° 1254/2014/UE

	Models Code	Unit of measurement	VORT PENTA EP	
			11509	VORT PLATT ES EP 11557
Supplier's name or trade mark	-	-	Vortice	Vortice
Specific Energy Consumption class SEC in average climate zone	-	-	E	E
Specific Energy Consumption class SEC average	kWh/m ² a	-	-11,1	-14,9
Specific Energy Consumption class SEC cold		-	-20,7	-24,9
Specific Energy Consumption class SEC warm		-	0,4	-3,9
Declared typology	-	-	RVU-U*	RVU-U*
Type of drive	-	-	MSD***	MSD***
Type of heat recovery system HRS	-	-	None	None
Thermal efficiency of heat recovery at reference air flow	%	-	NA	NA
Maximum flow rate	m ³ /s	-	268	280
Electric power input of the fan drive, including any motor control equipment, at maximum flow rate	W	-	80	32,8
Sound power level LWA	LWA [dB(A)]	-	50	47
Reference flow rate	m ³ /s	-	0,0521	0,0544
Reference pressure difference	Pa	-	90	50
SPI	W/(m ³ /h)	-	0,1935	0,07143
Control factor CTRL	%	-	1	1
Control typology	-	-	manual	manual
Maximum internal leakage rates	-	-	NA	NA
Maximum external leakage rates	%	-	9,6	9,6
Mixing rate	-	-	NA	NA
Airflow sensitivity to pressure variations at + 20 Pa and - 20 Pa	m ³ /h	-	NA	NA
Indoor/outdoor air tightness	-	-	NA	NA
Annual electricity consumption (AEC)	kWh electricity/a	-	242	89
AHS average Annual heating saved	kWh primary energy/a	-	1715	1715
AHS cold Annual heating saved		-	3732	2732
AHS warm Annual heating saved		-	632	632
Position and description of visual filter warning	-	-	NA	NA

* RVU-U: Unit Ventilation Residential - Unidirectional
 ** NRVU-U: Unit Ventilation Non Residential - Unidirectional
 *** MSD: Multi-Speed Drive



RESIDENTIAL VENTILATION

DIMENSIONS

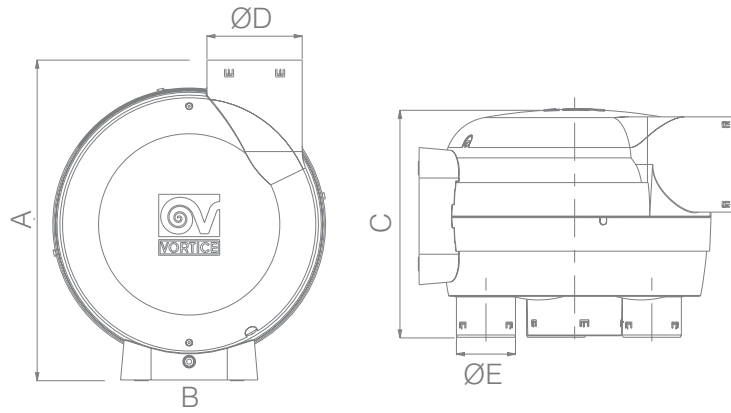

Models	A	B	C	Ø D	Ø E
VORT PENTA EP	420	358	300	125	77.5
VORT PENTA ES EP					

Dimensions (mm)

PERFORMANCE CURVES

POWER CONSUMPTION
 — max
 — med
 — min

PERFORMANCE CURVES
 — max
 — med
 — min

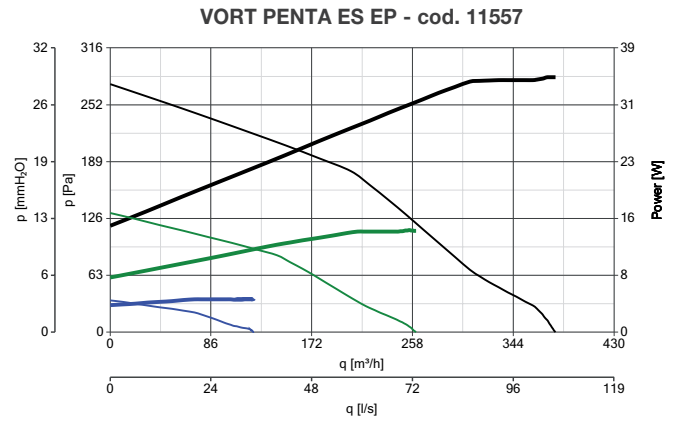
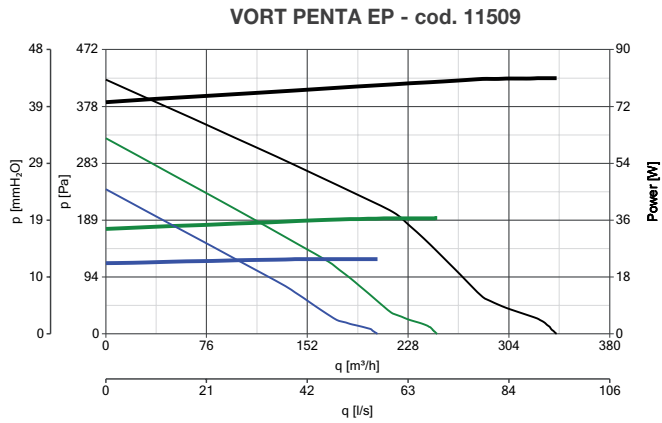

ACCESSORIES ON REQUEST





Models	Description	Code	Product
	Regulator	15 ³ /h 22324	All products
		30 ³ /h 22325	
	Additional spigot - Hygro 80	22847	All products

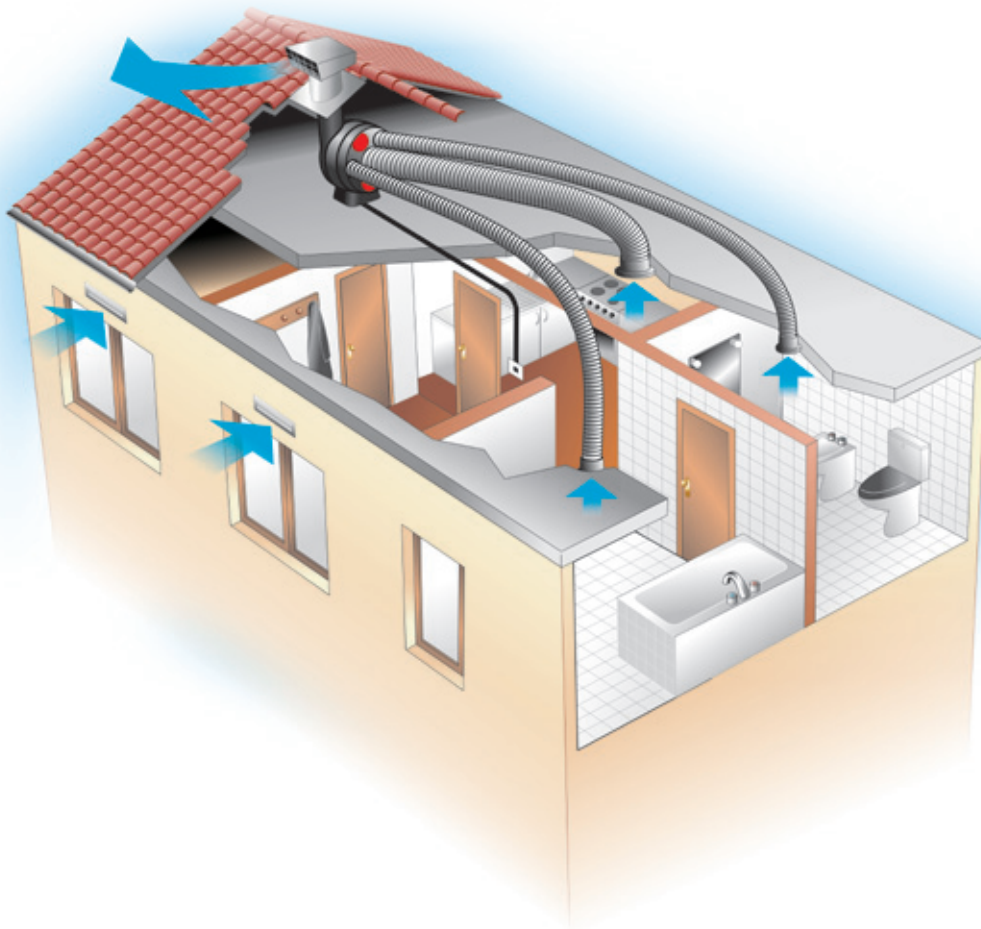

Accessories on request (description and technical data on page 146)

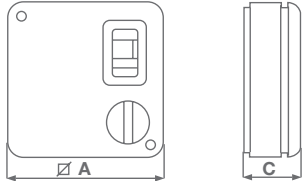
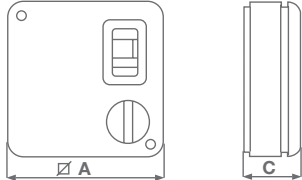
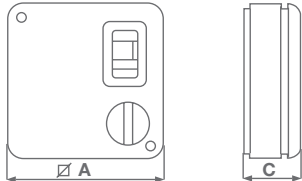
APPLICATIONS

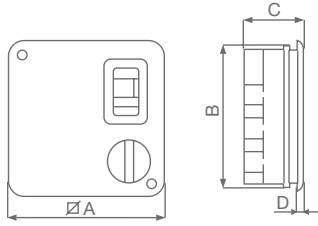

ACCESSORIES

Models	Description	Code										
	<p>C4VM16 - Four-speed selector, single phase</p> <table border="1"> <thead> <tr> <th>Models</th> <th>∅ A</th> <th>C</th> </tr> </thead> <tbody> <tr> <td>C4VM16</td> <td>120</td> <td>55</td> </tr> </tbody> </table> <p>Dimensions (mm)</p>	Models	∅ A	C	C4VM16	120	55	 <p>12949</p>				
Models	∅ A	C										
C4VM16	120	55										
	<p>C3VM3 - Three speed selector, single phase</p> <table border="1"> <thead> <tr> <th>Models</th> <th>∅ A</th> <th>C</th> </tr> </thead> <tbody> <tr> <td>C3VM3</td> <td>120</td> <td>43</td> </tr> </tbody> </table> <p>Dimensions (mm)</p>	Models	∅ A	C	C3VM3	120	43	 <p>14021</p>				
Models	∅ A	C										
C3VM3	120	43										
	<p>C 1.5 Non reversible variable electronic speed controller</p> <ul style="list-style-type: none"> - Not suitable for products with timer or automatic shutters - Convertible to flush-mounted using SCB5 kit - Weight 0.2 Kg - Maximum load: 200 W (for C 1.5) - Double insulation <table border="1"> <thead> <tr> <th>Models</th> <th>∅ A</th> <th>C</th> </tr> </thead> <tbody> <tr> <td>C 1.5</td> <td>120</td> <td>43</td> </tr> </tbody> </table> <p>Dimensions (mm)</p>	Models	∅ A	C	C 1.5	120	43	 <p>12966</p>				
Models	∅ A	C										
C 1.5	120	43										
	<p>SCNRB Non reversible variable electronic speed controller (built-in)</p> <ul style="list-style-type: none"> - Not suitable for products with timer or automatic shutters - Weight 0.2 Kg - Maximum load: 200 W - Double insulation <table border="1"> <thead> <tr> <th>Models</th> <th>∅ A</th> <th>B</th> <th>C</th> <th>D</th> </tr> </thead> <tbody> <tr> <td>SCNRB</td> <td>142</td> <td>135</td> <td>59.5</td> <td>4.5</td> </tr> </tbody> </table> <p>Dimensions (mm)</p>	Models	∅ A	B	C	D	SCNRB	142	135	59.5	4.5	 <p>12971</p>
Models	∅ A	B	C	D								
SCNRB	142	135	59.5	4.5								
	<p>C5 0.5 5 position speed controller</p> <ul style="list-style-type: none"> - 5 speeds controller - Not suitable for timer, automatic, automatic timer and cord operated appliances - Convertible to flush-mounted using SCB5 kit - Weight 0.2 Kg - Double insulation Non reversible variable electronic speed controller (built-in) - Not suitable for products with timer or automatic shutters - Weight 0.2 Kg - Maximum load: 200 W - Double insulation <table border="1"> <thead> <tr> <th>Models</th> <th>∅ A</th> <th>C</th> </tr> </thead> <tbody> <tr> <td>C 1.5</td> <td>120</td> <td>43</td> </tr> </tbody> </table> <p>Dimensions (mm)</p>	Models	∅ A	C	C 1.5	120	43	 <p>12987</p>				
Models	∅ A	C										
C 1.5	120	43										

Models	Description	Code										
	SPEED REGULATOR - Three-speed selector switch <table border="1"> <thead> <tr> <th>Models</th> <th>∅ A</th> <th>C</th> </tr> </thead> <tbody> <tr> <td>SR</td> <td>120</td> <td>43</td> </tr> </tbody> </table> Dimensions (mm)	Models	∅ A	C	SR	120	43	22478				
Models	∅ A	C										
SR	120	43										
	KIT SCB - Kit to convert C1.5 to built-in model KIT SCB5 - Kit to convert C5 0.5 to built-in model <table border="1"> <thead> <tr> <th>Models</th> <th>∅ A</th> <th>B</th> <th>C</th> <th>D</th> </tr> </thead> <tbody> <tr> <td>SCB/SBC5</td> <td>142</td> <td>135</td> <td>59.5</td> <td>4.5</td> </tr> </tbody> </table> Dimensions (mm)	Models	∅ A	B	C	D	SCB/SBC5	142	135	59.5	4.5	22481 22483
Models	∅ A	B	C	D								
SCB/SBC5	142	135	59.5	4.5								
	Remote Control Unit (only for cod. 11635) Wired control box integrating the power supply (no external device needed), allowing switching on/off and selection of operating mode. Up to 4 products can be wired simultaneously to 1 controller.	22693										

Sensor units





Sensor units are appliances which detect certain environmental conditions (humidity, temperature, human motion, odour and smoke concentration) and automatically activate the extractor fans. They may also be connected to Vortice control units, enhancing their functions.

- Supply voltage 220-240 V
- Frequency: 50/60 Hz
- Max load 3A
- Operating temperature: 50°C
- Protection rating IP20

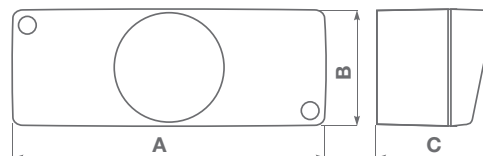



A	B	C
144	54	55.8





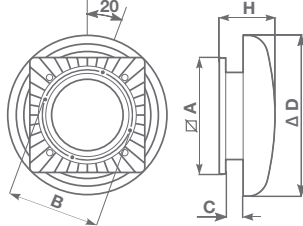

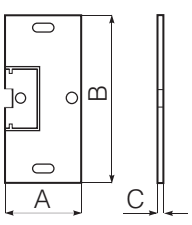
Dimensions (mm)

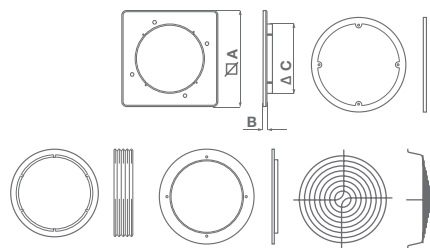

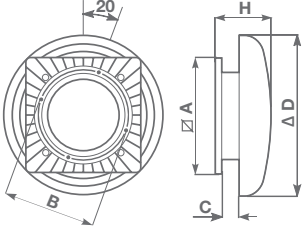

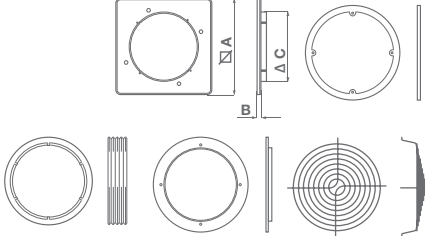

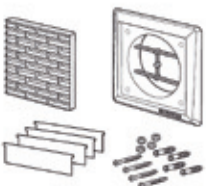
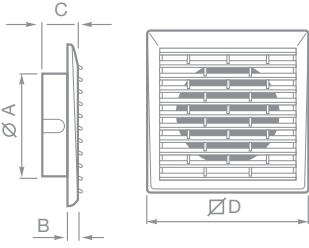

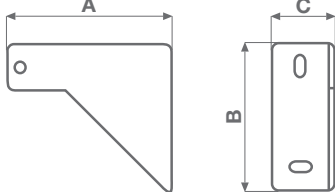
Models	Description	Code
	C HCS Checks the relative humidity of the air: the extractor fan is activated automatically when the relative humidity percentage exceeds 65%. Otherwise, the appliance starts automatically a few seconds after the light is switched on and continues to run for a set time after it has been switched off again; this time period can be adjusted to a value between 3 and 20 minutes using a built-in trimmer.	12994
	C TEMP Checks the temperature of the surrounding air: the extractor fan is activated automatically when a certain temperature is recorded; this can be adjusted, using an external trimmer, to a value between 10 °C and 40 °C above the set threshold. A timer keeps it running after the temperature has fallen below the set threshold, for a period of time which can be adjusted to a value between 3 and 20 minutes using a built-in trimmer.	12992
	C SMOKE Checks the quality of the air when the air contains cigarette smoke, odours and other pollutants: the extractor fan is activated automatically when a concentration of odours higher than the set value is detected; this value can be adjusted using an external trimmer. A pre-set timer, which can be adjusted to a value between 3 and 20 minutes using a built-in trimmer, keeps the extractor fan running for the desired period of time.	12993
	C PIR Checks for human motion in the room: the extractor fan is activated automatically for a specified time period, which can be adjusted between 3 and 20 minutes using a trimmer, when human movement is detected in its range.	12998
	C TIMER Checks the operating time of the appliance to which it is connected: the extractor fan is activated automatically a few seconds after the light is switched on and continues to run for a set time, which can be adjusted to a value between 3 and 20 minutes using a built-in trimmer, after it has been switched off again.	12999



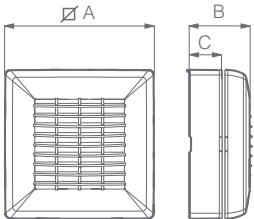
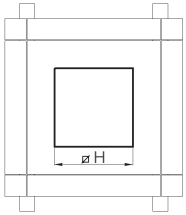
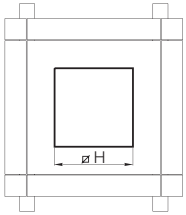

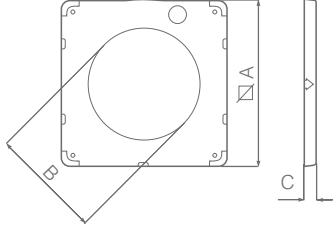

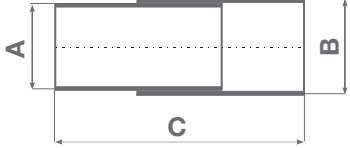

ACCESSORIES

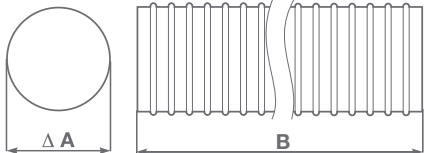
Models	Description	Code																													
	KIT TE - Roof cowl/wind baffle kit 150/6" - 230/9" - 300/12"		13001 13002 13003																												
	<table border="1"> <thead> <tr> <th>Models</th> <th>Code</th> <th>∅ A</th> <th>B</th> <th>C</th> <th>∅ D</th> <th>H</th> </tr> </thead> <tbody> <tr> <td>150/6"</td> <td>13001</td> <td>215</td> <td>175</td> <td>28</td> <td>300</td> <td>111</td> </tr> <tr> <td>230/9"</td> <td>13002</td> <td>294</td> <td>249</td> <td>30</td> <td>400</td> <td>145</td> </tr> <tr> <td>300/12"</td> <td>13003</td> <td>390</td> <td>316</td> <td>33</td> <td>534</td> <td>181</td> </tr> </tbody> </table>			Models	Code	∅ A	B	C	∅ D	H	150/6"	13001	215	175	28	300	111	230/9"	13002	294	249	30	400	145	300/12"	13003	390	316	33	534	181
	Models			Code	∅ A	B	C	∅ D	H																						
	150/6"			13001	215	175	28	300	111																						
230/9"	13002	294	249	30	400	145																									
300/12"	13003	390	316	33	534	181																									
Dimensions (mm)																															
	KIT SO - Ceiling, false ceiling and panel kit 150/6"-230/9" - 300/12"		13012 13014																												
	<table border="1"> <thead> <tr> <th>Models</th> <th>Code</th> <th>∅ A</th> <th>B</th> <th>C</th> </tr> </thead> <tbody> <tr> <td>150/6"</td> <td>13012</td> <td>215</td> <td>175</td> <td>28</td> </tr> <tr> <td>230/9"</td> <td>13014</td> <td>294</td> <td>249</td> <td>30</td> </tr> </tbody> </table>			Models	Code	∅ A	B	C	150/6"	13012	215	175	28	230/9"	13014	294	249	30													
	Models			Code	∅ A	B	C																								
150/6"	13012	215	175	28																											
230/9"	13014	294	249	30																											
Dimensions (mm)																															
	KIT ML - Deep wall installation kit 150/6" - 230/9" - 300/12"		13015 13016 13017																												
	<table border="1"> <thead> <tr> <th>Models</th> <th>Code</th> <th>∅ A</th> <th>B</th> <th>∅ C</th> <th>D</th> <th>H</th> </tr> </thead> <tbody> <tr> <td>KIT ML150/6"</td> <td>13015</td> <td>294</td> <td>8</td> <td>171</td> <td>30</td> <td>94</td> </tr> <tr> <td>KIT ML 230/9"</td> <td>13016</td> <td>393</td> <td>8</td> <td>240</td> <td>30</td> <td>125</td> </tr> <tr> <td>KIT ML300/12"</td> <td>13017</td> <td>487</td> <td>8</td> <td>300</td> <td>41</td> <td>142</td> </tr> </tbody> </table>			Models	Code	∅ A	B	∅ C	D	H	KIT ML150/6"	13015	294	8	171	30	94	KIT ML 230/9"	13016	393	8	240	30	125	KIT ML300/12"	13017	487	8	300	41	142
	Models			Code	∅ A	B	∅ C	D	H																						
	KIT ML150/6"			13015	294	8	171	30	94																						
KIT ML 230/9"	13016	393	8	240	30	125																									
KIT ML300/12"	13017	487	8	300	41	142																									
Dimensions (mm)																															
	KIT MU - Wall mounting kit with rods		13018																												
	<table border="1"> <thead> <tr> <th>Models</th> <th>A</th> <th>∅ B</th> </tr> </thead> <tbody> <tr> <td>KIT MU</td> <td>380</td> <td>M4</td> </tr> </tbody> </table>			Models	A	∅ B	KIT MU	380	M4																						
	Models			A	∅ B																										
KIT MU	380	M4																													
Dimensions (mm)																															
	KIT WV - Double opening window, secondary glazed kit KIT WV 150/6" - KIT WV 230/9" - KIT WV 300/12"		13021 13022 13023																												
	<table border="1"> <thead> <tr> <th>Models</th> <th>Code</th> <th>∅ A</th> <th>B</th> <th>C</th> </tr> </thead> <tbody> <tr> <td>KIT WV 150/6"</td> <td>13021</td> <td>215</td> <td>7</td> <td>157</td> </tr> <tr> <td>KIT WV 230/9"</td> <td>13022</td> <td>294</td> <td>7</td> <td>233</td> </tr> <tr> <td>KIT WV 300/12"</td> <td>13023</td> <td>390</td> <td>7</td> <td>303</td> </tr> </tbody> </table>			Models	Code	∅ A	B	C	KIT WV 150/6"	13021	215	7	157	KIT WV 230/9"	13022	294	7	233	KIT WV 300/12"	13023	390	7	303								
	Models			Code	∅ A	B	C																								
	KIT WV 150/6"			13021	215	7	157																								
KIT WV 230/9"	13022	294	7	233																											
KIT WV 300/12"	13023	390	7	303																											
Dimensions (mm)																															

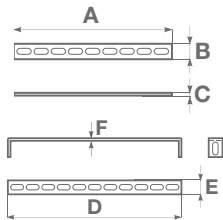

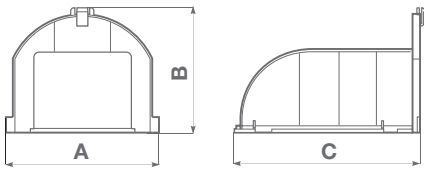
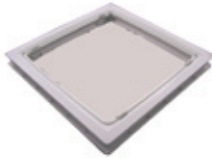
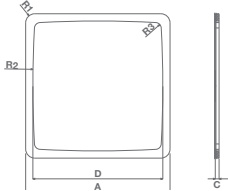

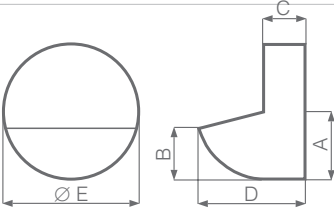

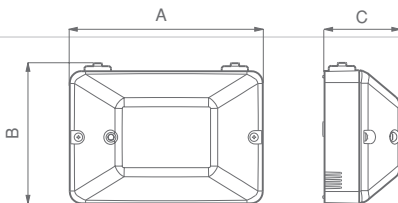
Models	Description	Code																														
	<p>KIT SA 230/9" - Darkroom cowl kit</p> <table border="1" data-bbox="384 629 759 696"> <thead> <tr> <th>∅ A</th> <th>B</th> <th>C</th> <th>∅ D</th> <th>H</th> </tr> </thead> <tbody> <tr> <td>294</td> <td>249</td> <td>30</td> <td>400</td> <td>145</td> </tr> </tbody> </table> <p>Dimensions (mm)</p> 	∅ A	B	C	∅ D	H	294	249	30	400	145	<p>13004</p>																				
∅ A	B	C	∅ D	H																												
294	249	30	400	145																												
	<p>KIT FF - Double opening window, secondary glazed kit KIT FF 150/6" - KIT FF 230/9" - KIT FF 300/12"</p> <table border="1" data-bbox="384 875 807 999"> <thead> <tr> <th>Models</th> <th>Code</th> <th>∅ A</th> <th>B</th> <th>C</th> </tr> </thead> <tbody> <tr> <td>KIT FF 150/6"</td> <td>13024</td> <td>215</td> <td>7</td> <td>157</td> </tr> <tr> <td>KIT FF 230/9"</td> <td>13025</td> <td>294</td> <td>7</td> <td>233</td> </tr> <tr> <td>KIT FF 300/12"</td> <td>13026</td> <td>390</td> <td>7</td> <td>303</td> </tr> </tbody> </table> <p>Dimensions (mm)</p> 	Models	Code	∅ A	B	C	KIT FF 150/6"	13024	215	7	157	KIT FF 230/9"	13025	294	7	233	KIT FF 300/12"	13026	390	7	303	<p>13024 13025 13026</p>										
Models	Code	∅ A	B	C																												
KIT FF 150/6"	13024	215	7	157																												
KIT FF 230/9"	13025	294	7	233																												
KIT FF 300/12"	13026	390	7	303																												
	<p>KIT TC - Duct diameter for Spigot Plate</p> <table border="1" data-bbox="384 1144 679 1267"> <thead> <tr> <th>Models</th> <th>Code</th> <th>∅ D</th> </tr> </thead> <tbody> <tr> <td>KIT TC 150/6"</td> <td>13024</td> <td>215</td> </tr> <tr> <td>KIT TC 230/9"</td> <td>13025</td> <td>294</td> </tr> <tr> <td>KIT TC 300/12"</td> <td>13026</td> <td>390</td> </tr> </tbody> </table> <p>Dimensions (mm)</p> 	Models	Code	∅ D	KIT TC 150/6"	13024	215	KIT TC 230/9"	13025	294	KIT TC 300/12"	13026	390	<p>13027 13028 13029</p>																		
Models	Code	∅ D																														
KIT TC 150/6"	13024	215																														
KIT TC 230/9"	13025	294																														
KIT TC 300/12"	13026	390																														
	<p>KIT MU Wall mounting kit with rods</p> <table border="1" data-bbox="384 1397 815 1554"> <thead> <tr> <th>Models</th> <th>Code</th> <th>∅ A</th> <th>B</th> <th>C</th> <th>∅ D</th> </tr> </thead> <tbody> <tr> <td>D 100</td> <td>22140</td> <td>99</td> <td>8</td> <td>20</td> <td>140</td> </tr> <tr> <td>D 125</td> <td>22141</td> <td>119</td> <td>8</td> <td>20</td> <td>160</td> </tr> <tr> <td>D 150</td> <td>22142</td> <td>155</td> <td>8</td> <td>20</td> <td>198</td> </tr> <tr> <td>D 90</td> <td>22143</td> <td>92.5</td> <td>8</td> <td>20</td> <td>140</td> </tr> </tbody> </table> <p>Dimensions (mm)</p> 	Models	Code	∅ A	B	C	∅ D	D 100	22140	99	8	20	140	D 125	22141	119	8	20	160	D 150	22142	155	8	20	198	D 90	22143	92.5	8	20	140	<p>22140 22141 22142 22143</p>
Models	Code	∅ A	B	C	∅ D																											
D 100	22140	99	8	20	140																											
D 125	22141	119	8	20	160																											
D 150	22142	155	8	20	198																											
D 90	22143	92.5	8	20	140																											
	<p>CA-MU Galvanized sheet-metal brackets For wall or ceiling mounting</p> <table border="1" data-bbox="384 1749 655 1827"> <thead> <tr> <th>A</th> <th>B</th> <th>C</th> </tr> </thead> <tbody> <tr> <td>144</td> <td>54</td> <td>55.8</td> </tr> </tbody> </table> <p>Dimensions (mm)</p> 	A	B	C	144	54	55.8	<p>22674</p>																								
A	B	C																														
144	54	55.8																														

ACCESSORIES

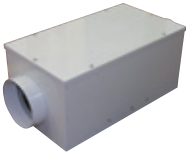
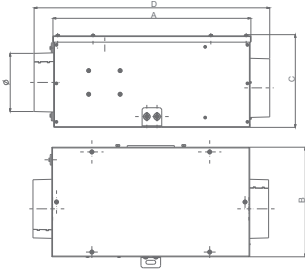
Models	Description		Code					
	KIT TO WINDOW-MOUNT Will allow any Vortice® Punto unit to be fitted to any single or double glazed window. IPX4; Insulation: Cl.II; Weight Kg. 0.85/1.15/1.56.							
	Models	Code		∅ A	B	C	∅ hole glass	Thickness max
	F 100/4"	22131		158	69	22	123÷128	20
	F 120/5"	22132		179	80	33	143÷148	20
F 150/6"	22133	213	87	40	178÷183	20		
Dimensions (mm)								
	RECESSED CEILING INSTALLATION KIT							
	Models	Code		∅ H				
	MICRO	22491		268				
	MEDIO	22492		285				
SUPER	22493	330						
Dimensions (mm)								
	RUBBER CEILING KIT Made of soft rubber to prevent water infiltration and to maintain IPX4 protection on all surfaces.							
	Models	Code		∅ A	B	C		
	S 100/4"	22154		166	99	10.5		
	S 120/5"	22155		187	119	10.5		
S 150/6"	22156	222	156	10.5				
Dimensions (mm)								
	LOFT MOUNTING BRACKETS							
	Models	Code		A	B			
	D 90/100	22259		22.5	115			
	D 120	22260		22.5	135			
D 150	22261	222	172					
Dimensions (mm)								
	TELESCOPIC WALL LINER							
	Models	Code		A	B	C		
	D 100	22253		110	114	200-380		
	D 120	22254		130	135	200-380		
D 150	22258	160	168	200-380				
Dimensions (mm)								

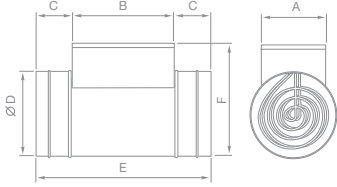
Models	Description		Code																																	
	FLEXIBLE DUCT Flexible PVC duct (extendable up to 3 m)		22250 22251 22252																																	
	<table border="1"> <thead> <tr> <th>Models</th> <th>Code</th> <th>Ø A</th> <th>B</th> </tr> </thead> <tbody> <tr> <td>PVC Ø 100</td> <td>22250</td> <td>110</td> <td>3000</td> </tr> <tr> <td>PVC Ø 120</td> <td>22251</td> <td>130</td> <td>3000</td> </tr> <tr> <td>PVC Ø 150</td> <td>22252</td> <td>160</td> <td>3000</td> </tr> </tbody> </table> Dimensions (mm)			Models	Code	Ø A	B	PVC Ø 100	22250	110	3000	PVC Ø 120	22251	130	3000	PVC Ø 150	22252	160	3000																	
Models	Code	Ø A	B																																	
PVC Ø 100	22250	110	3000																																	
PVC Ø 120	22251	130	3000																																	
PVC Ø 150	22252	160	3000																																	
	FALSE CEILING KIT Kit for false ceiling installations (max. height 40 cm)		22815 22823																																	
	<table border="1"> <thead> <tr> <th>Models</th> <th>Code</th> <th>A</th> <th>B</th> <th>C</th> <th>D</th> <th>E</th> <th>F</th> </tr> </thead> <tbody> <tr> <td>VP-C</td> <td>22815</td> <td>275</td> <td>20</td> <td>3</td> <td>324</td> <td>20</td> <td>3</td> </tr> <tr> <td>Kit false ceiling</td> <td>22823</td> <td>275</td> <td>20</td> <td>3</td> <td>226</td> <td>20</td> <td>3</td> </tr> </tbody> </table> Dimensions (mm)			Models	Code	A	B	C	D	E	F	VP-C	22815	275	20	3	324	20	3	Kit false ceiling	22823	275	20	3	226	20	3									
Models	Code	A	B	C	D	E	F																													
VP-C	22815	275	20	3	324	20	3																													
Kit false ceiling	22823	275	20	3	226	20	3																													
	HORIZONTAL OUTLET SPIGOT For fitting to extractors to direct the outlet horizontally, 105x82 mm, white, plastic for Ariett I		22841																																	
	<table border="1"> <thead> <tr> <th>Models</th> <th>A</th> <th>B</th> <th>C</th> </tr> </thead> <tbody> <tr> <td>Outlet spigot</td> <td>105</td> <td>82</td> <td>175</td> </tr> </tbody> </table> Dimensions (mm)			Models	A	B	C	Outlet spigot	105	82	175																									
Models	A	B	C																																	
Outlet spigot	105	82	175																																	
	SF CEILING KIT		22162 22163 22164																																	
	<table border="1"> <thead> <tr> <th>Models</th> <th>Code</th> <th>A</th> <th>B</th> <th>C</th> <th>D</th> <th>R1</th> <th>R2</th> <th>R3</th> </tr> </thead> <tbody> <tr> <td>SF Ø 90-100</td> <td>22162</td> <td>171</td> <td>171</td> <td>5</td> <td>150.5</td> <td>7.5</td> <td>1200</td> <td>7</td> </tr> <tr> <td>SF Ø 120</td> <td>22163</td> <td>190</td> <td>190</td> <td>5</td> <td>171</td> <td>12</td> <td>1400</td> <td>7.5</td> </tr> <tr> <td>SF Ø 150</td> <td>22164</td> <td>230</td> <td>230</td> <td>5</td> <td>205.5</td> <td>13</td> <td>1700</td> <td>5</td> </tr> </tbody> </table> Dimensions (mm)			Models	Code	A	B	C	D	R1	R2	R3	SF Ø 90-100	22162	171	171	5	150.5	7.5	1200	7	SF Ø 120	22163	190	190	5	171	12	1400	7.5	SF Ø 150	22164	230	230	5	205.5
Models	Code	A	B	C	D	R1	R2	R3																												
SF Ø 90-100	22162	171	171	5	150.5	7.5	1200	7																												
SF Ø 120	22163	190	190	5	171	12	1400	7.5																												
SF Ø 150	22164	230	230	5	205.5	13	1700	5																												
	M 10/4 AIR FLOW DEFLECTOR For fitting to the delivery side of extractor fans to direct the air flow in any required direction within 360° Weight kg. 0.2. Design: F. Trabucco - M. Vecchi		22310																																	
	<table border="1"> <thead> <tr> <th>Models</th> <th>A</th> <th>B</th> <th>C</th> <th>D</th> <th>E</th> </tr> </thead> <tbody> <tr> <td>M 10/4</td> <td>49.5</td> <td>37</td> <td>30</td> <td>77</td> <td>99</td> </tr> </tbody> </table> Dimensions (mm)			Models	A	B	C	D	E	M 10/4	49.5	37	30	77	99																					
Models	A	B	C	D	E																															
M 10/4	49.5	37	30	77	99																															
	GA 12V - Air flow deflector 220-240/12 V ~ 50 Hz; Weight Kg 0.8; Max °C 50; Insulation: Cl.II		22150 22151																																	
	<table border="1"> <thead> <tr> <th>Models</th> <th>Code</th> <th>A</th> <th>B</th> <th>C</th> </tr> </thead> <tbody> <tr> <td>GA12V</td> <td>22150</td> <td>161</td> <td>117</td> <td>65</td> </tr> <tr> <td>GA12V T</td> <td>22823</td> <td>161</td> <td>117</td> <td>65</td> </tr> </tbody> </table> Dimensions (mm)			Models	Code	A	B	C	GA12V	22150	161	117	65	GA12V T	22823	161	117	65																		
Models	Code	A	B	C																																
GA12V	22150	161	117	65																																
GA12V T	22823	161	117	65																																

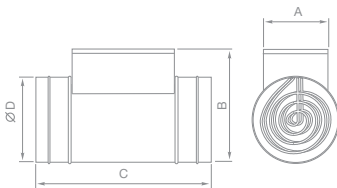
ACCESSORIES

Models	Description	Code																																				
	F5 External filter Box	22329																																				
	<p>EXTERNAL BY-PASS External and filtered (F5) by-pass can be activated manually allowing fresh air to by-pass for natural ventilation.</p> <table border="1"> <thead> <tr> <th>Models</th> <th>A</th> <th>B</th> <th>C</th> <th>D</th> <th>Ø</th> <th>W</th> </tr> </thead> <tbody> <tr> <td>EXT. BY-PASS</td> <td>504</td> <td>279</td> <td>263</td> <td>600</td> <td>150</td> <td>59</td> </tr> </tbody> </table> <p>Dimensions (mm)</p>	Models	A	B	C	D	Ø	W	EXT. BY-PASS	504	279	263	600	150	59	 <p>22131 22132 22133</p>																						
Models	A	B	C	D	Ø	W																																
EXT. BY-PASS	504	279	263	600	150	59																																
	<p>ELECTRIC HEATER To be installed in the ventilation system, always after the fan and/or the noise attenuator/air filter.</p> <table border="1"> <thead> <tr> <th>Models</th> <th>Code</th> <th>A</th> <th>B</th> <th>C</th> <th>Ø D</th> <th>E</th> <th>F</th> <th>Kg</th> </tr> </thead> <tbody> <tr> <td>500 W</td> <td>22467</td> <td>150</td> <td>285</td> <td>40</td> <td>10.5</td> <td>380</td> <td>250</td> <td>2.2</td> </tr> <tr> <td>1200 W</td> <td>22468</td> <td>150</td> <td>285</td> <td>40</td> <td>150</td> <td>380</td> <td>250</td> <td>2.6</td> </tr> <tr> <td>1800 W</td> <td>22469</td> <td>164</td> <td>278</td> <td>42</td> <td>147</td> <td>375</td> <td>250</td> <td>2.8</td> </tr> </tbody> </table> <p>Dimensions (mm)</p>	Models	Code	A	B	C	Ø D	E	F	Kg	500 W	22467	150	285	40	10.5	380	250	2.2	1200 W	22468	150	285	40	150	380	250	2.6	1800 W	22469	164	278	42	147	375	250	2.8	 <p>22467 22468 22469</p>
Models	Code	A	B	C	Ø D	E	F	Kg																														
500 W	22467	150	285	40	10.5	380	250	2.2																														
1200 W	22468	150	285	40	150	380	250	2.6																														
1800 W	22469	164	278	42	147	375	250	2.8																														
	<p>ELECTRIC HEATER To be installed in the ventilation system, always after the fan and/or the noise attenuator/air filter.</p> <table border="1"> <thead> <tr> <th>Models</th> <th>Code</th> <th>A</th> <th>B</th> <th>C</th> <th>Ø D</th> </tr> </thead> <tbody> <tr> <td>200</td> <td>22734</td> <td>125</td> <td>230</td> <td>400</td> <td>125</td> </tr> <tr> <td>350</td> <td>22735</td> <td>150</td> <td>285</td> <td>400</td> <td>150</td> </tr> </tbody> </table> <p>Dimensions (mm)</p>	Models	Code	A	B	C	Ø D	200	22734	125	230	400	125	350	22735	150	285	400	150	 <p>22734 22735</p>																		
Models	Code	A	B	C	Ø D																																	
200	22734	125	230	400	125																																	
350	22735	150	285	400	150																																	
	<p>FLOW REGULATOR Flow regulator 15 m³/h; Flow regulator 30 m³/h</p>	22324 22325																																				
	<p>SILENCER Noise attenuator; Ø 125 mm; lenght 500 mm</p>	22366																																				

Cod. 5.170.084.998

09/16

Vortice Elettrosociali S.p.A
Strada Cerca, 2
Frazione di Zoate
20067 Tribiano (Milano)
Tel. (+39) 02 906991
Fax (+39) 02 90699314
Italia
www.vortice.com
export@vortice-italy.com

Vortice France
15-33, Rue Le Corbusier
CS 30007
94046 Créteil Cedex
Tél. (+33) 1.55.12.50.00
Fax (+33) 1.55.12.50.01
France
www.vortice-france.com
contact@vortice-france.com

Vortice Limited
Beeches House-Eastern Avenue
Burton on Trent
DE13 0BB
Tel. (+44) 1283-49.29.49
Fax (+44) 1283-54.41.21
United Kingdom
www.vortice.ltd.uk
sales@vortice.ltd.uk

